



**MZT PUMPI**

---

***End suction volute casing  
pumps series SCP  
ISO2858 / ISO5199***

---

***Technical catalog***

---

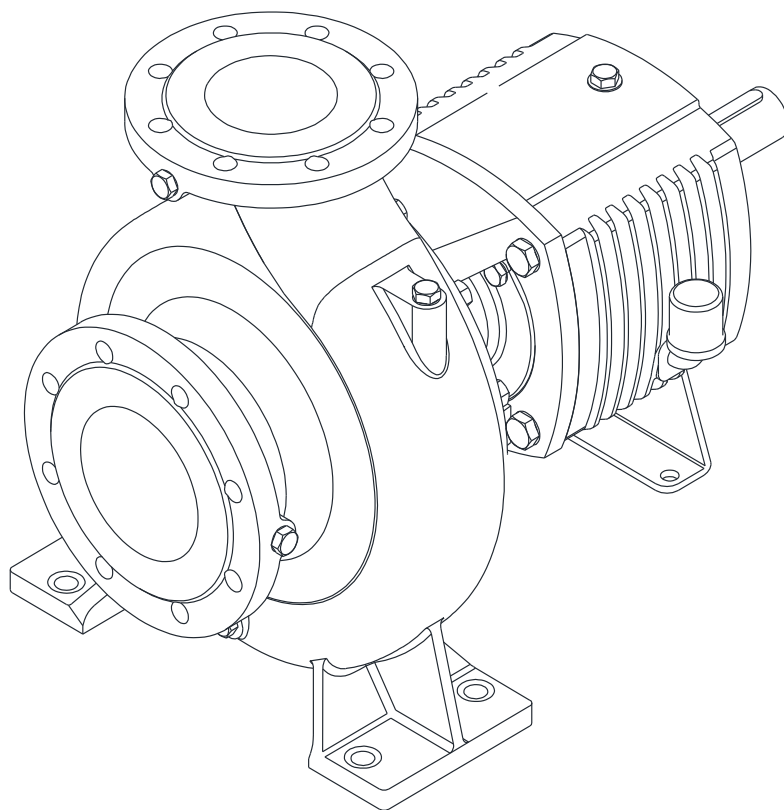



**CONTENTS:**

1. GENERAL INFORMATION .....	2
1.1. Introduction .....	2
1.2. Application .....	2
1.3. Pump type design .....	2
1.4. Pump type key .....	2
2. TECHNICAL DETAILS.....	3
2.1. Materials.....	3
2.2. Flange connections .....	3
2.3. Direction of rotation .....	3
2.4. Balancing .....	3
2.5. Shaft sealing .....	3
2.6. Back pull out design .....	3
2.7. Flange forces and moments.....	3
2.8. Testing and guaranties.....	3
2.9. Bearing brackets .....	4
2.10. Bearings and lubrication.....	4
3. DIMENSIONS - PUMP BARE SHAFT-OUTLINE DRAWING .....	5
4. ASSEMBLY DRAWING WITH PART LIST .....	6
5. PUMP EXPLODED VIEW .....	7
6. PERFORMANCE CURVES .....	8



**1. GENERAL INFORMATION**

**1.1. Introduction**

SCP series pumps are horizontal, single stage, end suction, radially split volute casing, designed in accordance with ISO2858 and ISO5199.

**1.2. Application**

SCP series can be applied for transport for liquid transfer and circulation of cold and hot clean or slightly polluted water, for handling aggressive organic and inorganic liquids in the chemical and petrochemical industries.

Typical applications in:

- Municipal water supply
- Food industry
- Chemical and petrochemical industry
- Energy sector
- Industrial plants
- Boiler feed and condensate systems
- Irrigation and dewatering
- General process industry and etc.

Capacity:	up to 2500 [m <sup>3</sup> /h]
Differential head:	up to 150 [m]
Design pressure	up to 16 [bar]
Speed:	up to 3600 [rpm]
Temperature range:	up to 160 [°C]

**1.3. Pump type design**

SCP type of pump is end suction centrifugal type of pump where following design solutions are applied:

- Horizontal design
- Foot mounted
- Not self-priming
- Single volute pump casing
- Closed impeller
- Beck pull out design
- Ratings and volute casing connections according ISO 2858

**1.4. Pump type key (Designation)**

Example:

**SCP - 50 - 200**

Type series

Discharge flange nominal diameter [mm]

Impeller nominal diameter

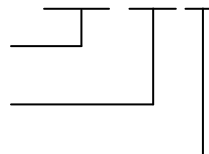

**2. TECHNICAL DETAILS****2.1. Materials**

	<b>Pump Part</b>	<b>Material</b>
1	Volute casing	Cast iron / Nodular cast iron / Bronze / Steel / Stainless steel / Duplex
2	Impeller	Cast iron / Nodular cast iron / Bronze / Steel / Stainless steel / Duplex
3	Casing cover	Cast iron / Bronze / Steel / Stainless steel
4	Shaft	Stainless Steel
5	Intermediate bearing	NBR / Composite / Bronze / Graphite
6	Impeller nut	Steel / Stainless steel
7	Wearing rings	Cast iron / Nodular cast iron / Bronze / Steel / Stainless steel / Duplex
8	Base	Steel welded construction
9	Column pipes	Steel / Stainless steel / Duplex

**2.2. Flange connections**

Suction (axial) and discharge (top) flanges are in accordance with EN 1092-1 PN16

Connecting flanges acc. DIN EN 1092 PN 16					
DN	Cf	df	Kf	Df	Lf
32	18	76	100	140	4xØ19
40	19	84	110	150	4xØ19
50	19	99	125	165	4xØ19
65	19	118	145	185	4xØ19
80	19	132	160	200	8xØ19
100	19	156	180	220	8xØ19
125	19	184	210	250	8xØ19
150	19	211	240	285	8xØ23
200	20	266	295	340	12xØ23
250	26	320	355	405	12xØ27
300	32	378	410	460	12xØ27
350	36	438	470	520	16xØ27
350	36	438	470	520	16xØ27

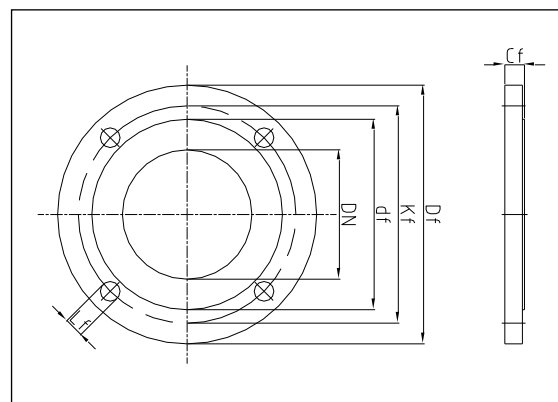
**2.3. Direction of rotation**

Direction of rotation is clock vice viewed from the motor side.

Direction of air cooling of the electric motor must be toward the pump side.

**2.4. Balancing**

Axial thrust is balanced by back vanes or sealing gap on both sides if impeller depends of the pump size and application.

**2.5. Shaft Sealing**

The shaft sealing could be arranged by soft packing, single or double mechanical seal.

In soft packing arrangements the shaft is protected by replaceable, stainless sleeve while the stuffing box can furnished with or without lantern ring.

Single mechanical seals are according EN 12756 (DIN 24960).

On special demand, pumps could be furnished with mechanical seal in accordance with the specific characteristics of the liquid and the operating conditions.

**2.6. Back pull out design**

Back pull out design allow dismantling of pumps without movement of electrical motor when spacer coupling is mounted.

**2.7. Flange forces and Moments**

SCP pumps are designed for handing forces and moments in accordance with ISO 5199

**2.8. Testing and Guarantees**

Each pump before delivery is tested:

- Hydrostatic test - 150 % over nominal pressure
- Performance tests - in accordance with ISO 9906



**2.9. Bearing brackets**

Eight different bearing bracket sizes cover the range of SCP pumps.

Outlet nozzle [mm]	Nominal impeller diameter								
	125	160	200	250	315	400	500	650	710
32	BB1	BB1	BB1	BB2					
40		BB1	BB1	BB2	BB2				
50		BB1	BB1	BB2	BB2				
65		BB2	BB2	BB2	BB3				
80		BB2	BB2	BB2	BB3	BB3			
100			BB2	BB3	BB3	BB3			
125				BB3	BB3	BB3			
150				BB3	BB4	BB4	BB4	BB6	
200				BB4	BB4	BB4	BB4	BB7	
250					BB4	BB5	BB5	BB7	BB7
300						BB6	BB6	BB7	BB7
350						BB6	BB6	BB8	BB8

**2.10. Bearings and lubrication****Motor side bearings**

Outlet nozzle [mm]	Nominal impeller diameter								
	125	160	200	250	315	400	500	650	710
32	2 x 7307	2 x 7307	2 x 7307	2 x 7307					
40		2 x 7307	2 x 7307	2 x 7307	2 x 7307				
50		2 x 7307	2 x 7307	2 x 7307	2 x 7307				
65		2 x 7307	2 x 7307	2 x 7307	2 x 7311				
80		2 x 7307	2 x 7307	2 x 7307	2 x 7311	2 x 7311			
100			2 x 7307	2 x 7311	2 x 7311	2 x 7311			
125				2 x 7311	2 x 7311	2 x 7311			
150				2 x 7311	2 x 7313	2 x 7313	2 x 7313	2 x 7319	
200				2 x 7313	2 x 7313	2 x 7313	2 x 7313	2 x 7324	
250					2 x 7313	2 x 7315	2 x 7315	2 x 7324	2 x 7324
300						2 x 7319	2 x 7319	2 x 7324	2 x 7324
350						2 x 7319	2 x 7319	2 x 7324	2 x 7324

**Impeller side bearings**

Outlet nozzle [mm]	Nominal impeller diameter								
	125	160	200	250	315	400	500	650	710
32	NU307	NU 307	NU 307	NU 307	-	-	-	-	2222
40	-	NU 307	NU 307	NU 307	NU 307				
50	-	NU 307	NU 307	NU 307	NU 307				
65	-	NU 307	NU 307	NU 307	NU 311				
80	-	NU 307	NU 307	NU 307	NU307	NU307			
100			NU307	NU307	NU307	NU307			
125				NU307	NU307	NU307			
150				NU307	NU313	NU313	NU313	NU416	
200				NU313	NU313	NU313	NU313	NU324	
250					NU313	NU413	NU413	NU324	NU324
300						NU416	NU416	NU324	NU324
350						NU416	NU416	NU324	NU324

**Lubrication : oil SAE 30**



**3. DIMENSIONS - PUMP BARE SHAFT OUTLINE DRAWING**

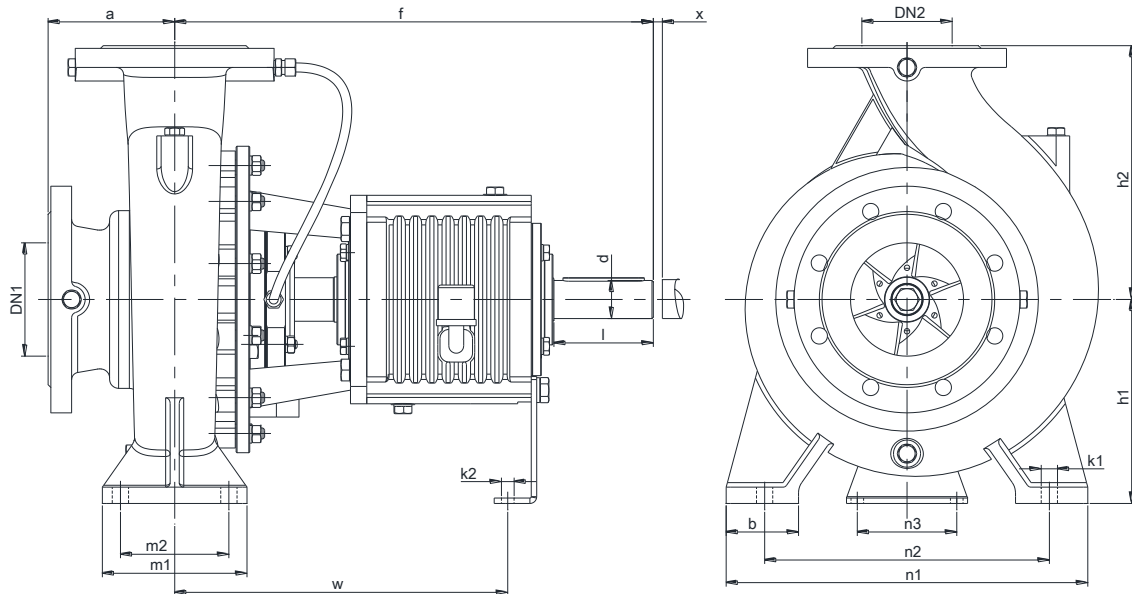

SIZE	Dimensions (mm)																	
	D1	D2	a	f	h1	h2	b	m1	m2	n1	n2	n3	w	x	d	l	k1	k2
32-125	50	32	80	385	112	140	50	100	70	190	140	110	285	100	24	50	M12	M12
32-160	50	32	80	385	132	160	50	100	70	240	190	140	285	100	24	50	M12	M12
32-200	50	32	80	385	160	180	50	100	70	240	190	140	285	100	24	50	M12	M12
32-250	50	32	100	500	180	225	65	125	95	320	250	190	370	100	32	80	M12	M12
40-160	65	40	80	385	132	160	50	100	70	240	190	140	285	100	24	50	M12	M12
40-200	65	40	100	385	160	180	50	100	70	265	212	165	285	100	24	50	M12	M12
40-250	65	40	100	500	180	225	65	125	95	320	250	190	370	100	32	80	M12	M12
40-315	65	40	125	500	200	250	65	125	95	345	280	215	370	100	32	80	M12	M12
50-160	80	50	100	385	160	180	50	100	70	265	212	165	285	100	24	50	M12	M12
50-200	80	50	100	385	160	200	50	100	70	265	212	165	285	100	24	50	M12	M12
50-250	80	50	125	500	180	225	65	125	95	320	250	190	370	100	32	80	M12	M12
50-315	80	50	125	500	225	280	65	125	95	345	280	215	370	100	32	80	M12	M12
65-125	80	65	100	385	132	160	50	100	70	240	190	110	285	100	24	50	M12	M12
65-160	100	65	100	500	160	200	65	125	95	280	212	150	370	100	32	80	M12	M12
65-200	100	65	100	500	180	225	65	125	95	320	250	190	370	140	32	80	M12	M12
65-250	100	65	125	500	200	250	80	160	120	360	280	200	370	140	32	80	M16	M12
65-315	100	65	125	530	225	280	80	160	120	400	315	240	370	140	42	110	M16	M12
80-125	100	80	100	385	160	180	65	125	95	280	212	110	285	140	24	50	M12	M12
80-160	125	80	125	500	180	225	65	125	95	320	250	190	370	140	32	80	M12	M12
80-200	125	80	125	500	180	250	65	125	95	345	280	215	370	140	32	80	M16	M12
80-250	125	80	125	500	225	280	80	160	120	400	315	240	370	140	32	80	M16	M12
80-315	125	80	125	530	250	315	80	160	120	400	315	240	370	140	42	110	M16	M12
80-400	125	80	125	530	280	355	80	160	120	435	355	275	370	140	42	110	M16	M12
100-200	125	100	125	500	200	280	80	160	120	360	280	200	370	140	32	80	M16	M12
100-250	125	100	140	530	225	280	80	160	120	400	315	240	370	140	42	110	M16	M12
100-315	125	100	140	530	250	315	80	160	120	400	315	240	370	140	42	110	M16	M12
100-400	125	100	140	530	280	355	100	200	150	500	400	300	370	140	42	110	M20	M12
125-250	150	125	140	530	250	355	80	160	120	400	315	240	370	140	42	110	M16	M12
125-315	150	125	140	530	280	355	100	200	150	500	400	300	370	140	42	110	M20	M12
125-400	150	125	140	530	315	400	100	200	150	500	400	300	370	140	42	110	M20	M12
150-250	200	150	160	530	280	375	100	200	150	500	400	300	370	180	42	110	M20	M12
150-315	200	150	160	670	315	400	100	200	150	550	450	350	500	180	48	110	M20	M16
150-400	200	150	160	670	315	450	100	200	150	550	450	350	500	180	48	110	M20	M16
150-500	200	150	180	670	375	500	100	200	150	550	450	350	500	180	48	110	M20	M16
200-250	200	200	180	670	355	425	100	200	150	550	450	350	500	180	48	110	M20	M16
200-315	250	200	200	670	355	450	110	200	150	550	450	350	500	180	48	110	M20	M16
200-400	250	200	180	670	355	500	100	200	150	550	450	350	500	180	48	110	M20	M16
200-500	250	200	200	670	425	560	100	200	150	660	560	460	565	180	60	140	M20	M16
200-650	250	200	250	900	500	670	225	400	300	1080	1000	630	680	250	75	150	M24	M16
250-315	300	250	250	670	400	560	130	260	190	690	560	430	500	180	48	110	M24	M16
250-400	300	250	200	720	425	600	130	260	190	800	670	540	515	180	60	140	M24	M16
250-500	300	250	200	720	475	670	130	260	190	800	670	540	515	180	60	140	M24	M16
250-650	300	250	300	1090	500	750	225	400	300	1080	1000	630	730	250	95	170	M24	M16
250-710	300	250	300	1080	600	800	225	400	300	1250	1170	800	720	250	95	170	M24	M16
300-400	350	300	300	900	500	630	180	360	250	900	750	540	680	250	75	150	M24	M16
300-500	350	300	300	900	560	750	225	400	300	1080	1000	630	680	250	75	150	M24	M16
300-650	350	300	300	1090	600	800	225	400	300	1250	1170	800	730	250	95	170	M24	M16
300-710	350	300	300	1090	600	850	225	400	300	1250	1170	800	720	250	95	170	M24	M16
350-400	350	350	350	930	600	750	225	400	300	1250	1170	800	710	315	75	150	M24	M16
350-500	350	350	300	900	670	850	225	400	300	1250	1170	800	630	250	75	150	M24	M16
350-650	400	350	300	1150	630	850	225	400	300	1250	1170	800	740	250	110	210	M24	M16
350-710	400	350	300	1150	630	900	225	400	300	1250	1170	800	740	250	110	210	M24	M16



**4. ASSEMBLY DRAWING WITH PART LIST**

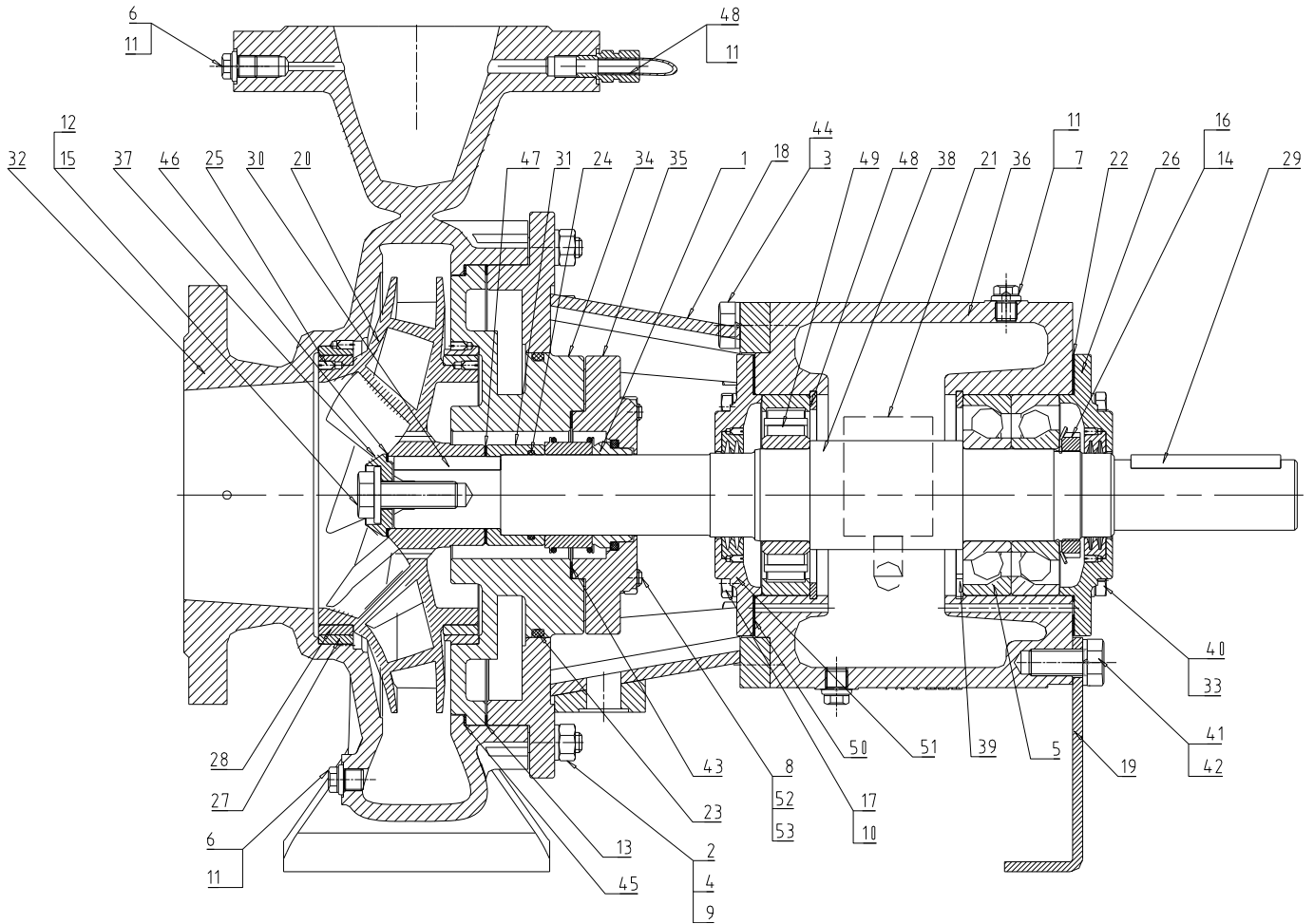

1	Mechanical seal	15	Washer	29	Key	43	Gasket
2	Nut	16	Locking washer	30	Key	44	Washer
3	Screw	17	Screw	31	Sleeve	45	Gasket
4	Washer	18	Console	32	Volute casing	46	Gasket
5	Ball bearings	19	Foot	33	Washer	47	Gasket
6	Screw	20	Impeller	34	Volute casing cover	48	Pipe (hose)
7	Vent screw	21	Constant oil leveler	35	Mechanical seal cover	49	Cylindrical bearing
8	Screw	22	Gasket	36	Bearing bracket	50	Gasket
9	Screw	23	O-ring	37	Disc	51	Bearing cover
10	Washer	24	O-ring	38	Shaft	52	Nut
11	Washer	25	Screw for wearing rings fixing	39	Circlip	53	Washer
12	Impeller fixing screw	26	Bearing cover	40	Screw		
13	Gasket	27	Casing wearing ring	41	Screw		
14	Lock nut	28	Impeller wearing ring	42	Washer		



**5. PUMP EXPLODED VIEW**

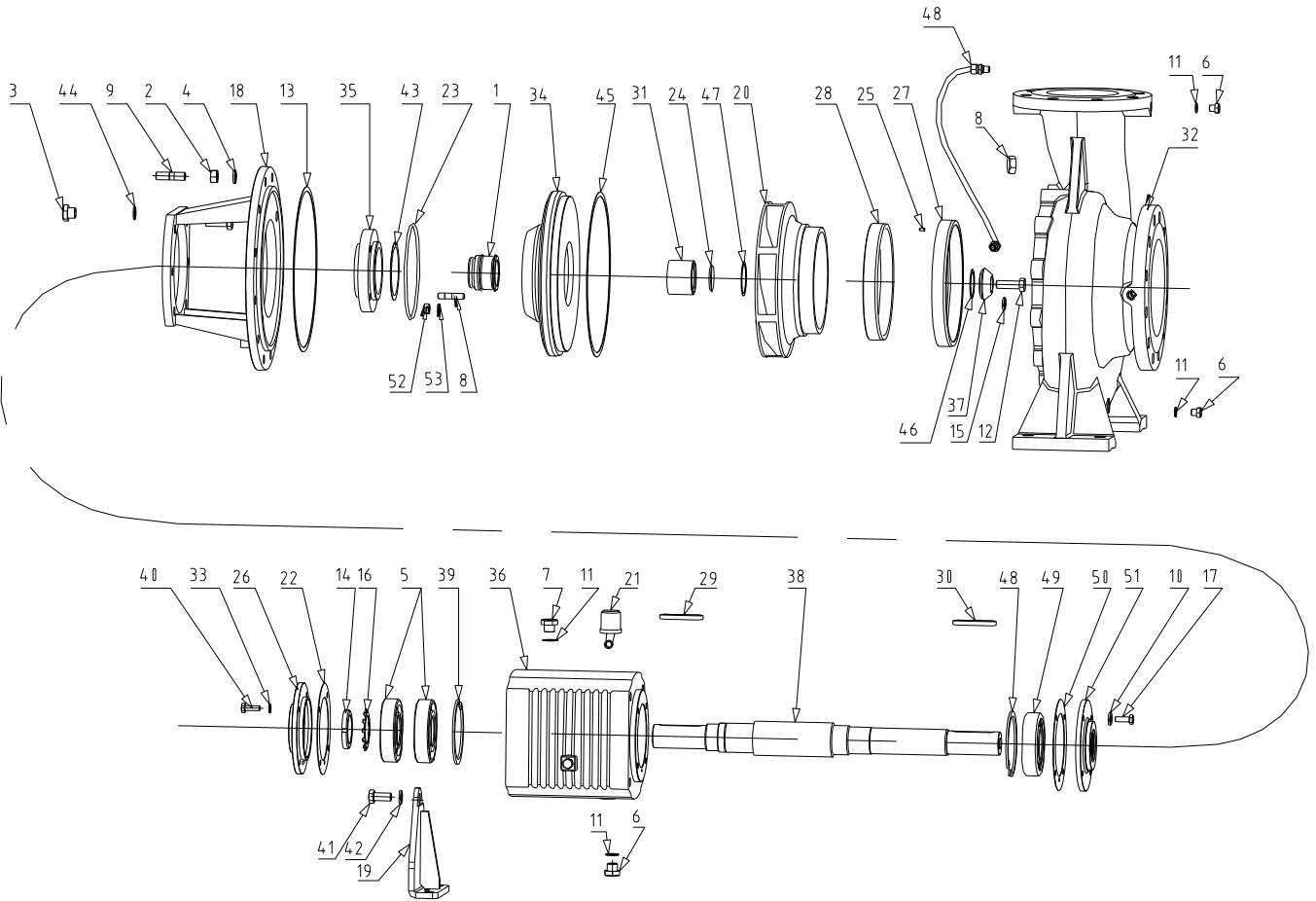

1	Mechanical seal	15	Washer	29	Key	43	Gasket
2	Nut	16	Locking washer	30	Key	44	Washer
3	Screw	17	Screw	31	Sleeve	45	Gasket
4	Washer	18	Console	32	Volute casing	46	Gasket
5	Ball bearings	19	Foot	33	Washer	47	Gasket
6	Screw	20	Impeller	34	Volute casing cover	48	Pipe (hose)
7	Vent screw	21	Constant oil leveler	35	Mechanical seal cover	49	Cylindrical bearing
8	Screw	22	Gasket	36	Bearing bracket	50	Gasket
9	Screw	23	O-ring	37	Disc	51	Bearing cover
10	Washer	24	O-ring	38	Shaft	52	Nut
11	Washer	25	Screw for wearing rings fixing	39	Circlip	53	Washer
12	Impeller fixing screw	26	Bearing cover	40	Screw		
13	Gasket	27	Casing wearing ring	41	Screw		
14	Lock nut	28	Impeller wearing ring	42	Washer		



**6. PERFORMANCE CURVES**

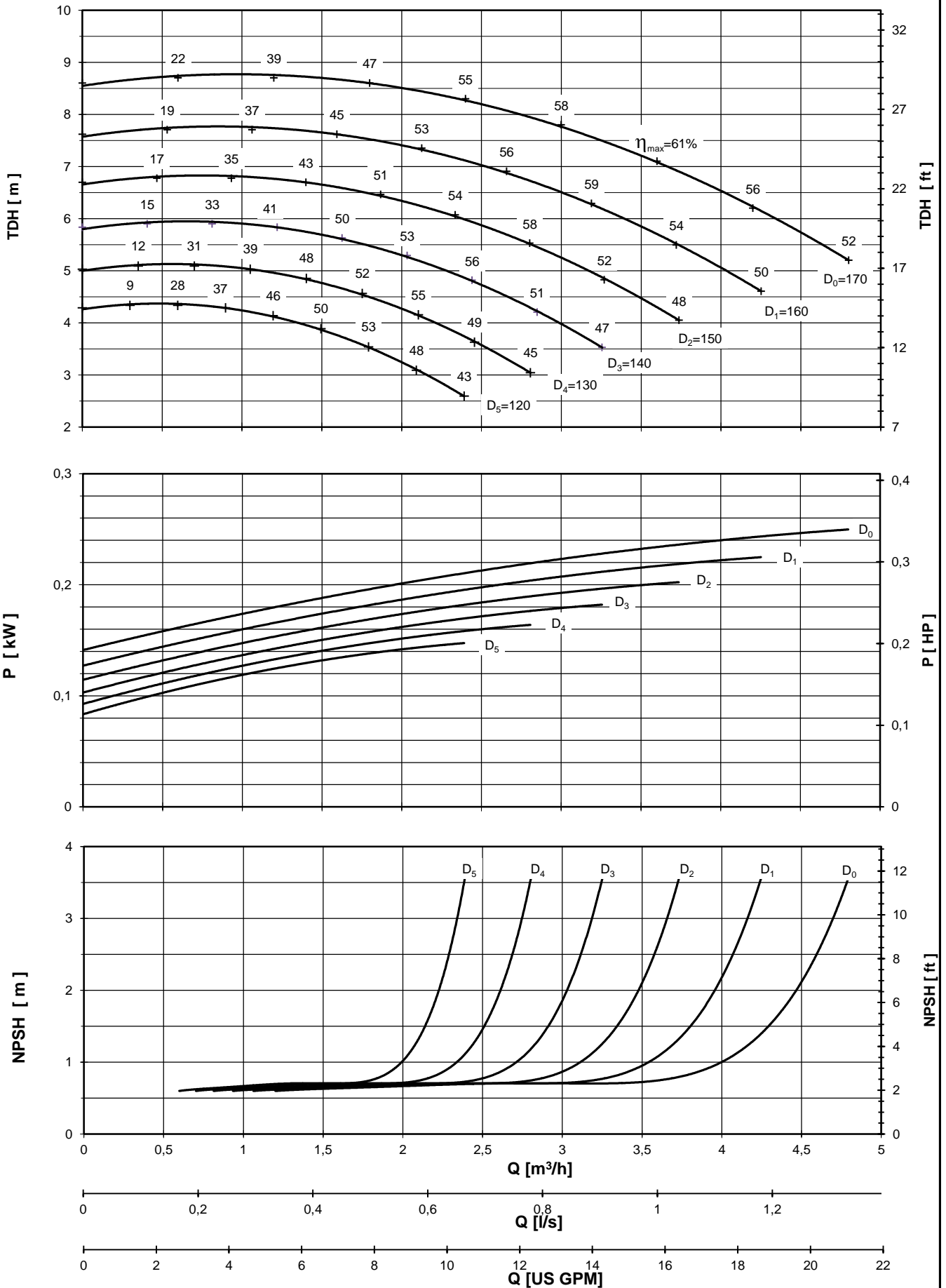

Performance curves are valid for clean cold water-kinematic viscosity 1 [mm²/s], density 1000 [kg/m³]. Methods and tolerances of presented performance curves are in accordance with ISO 9906 - Annex A

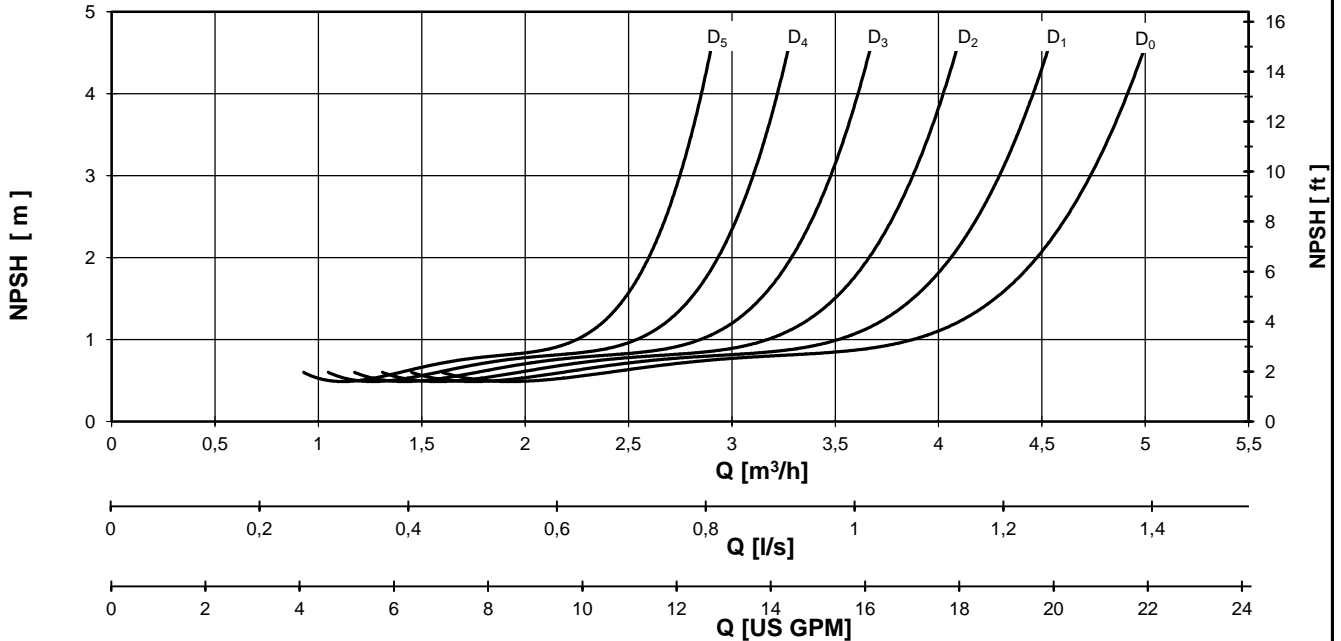
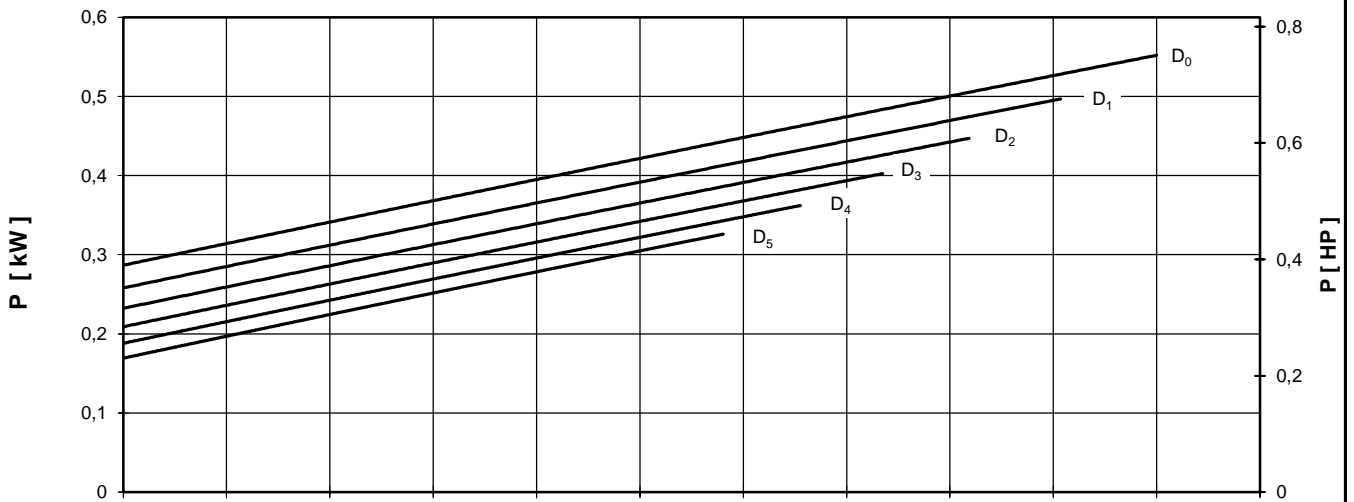
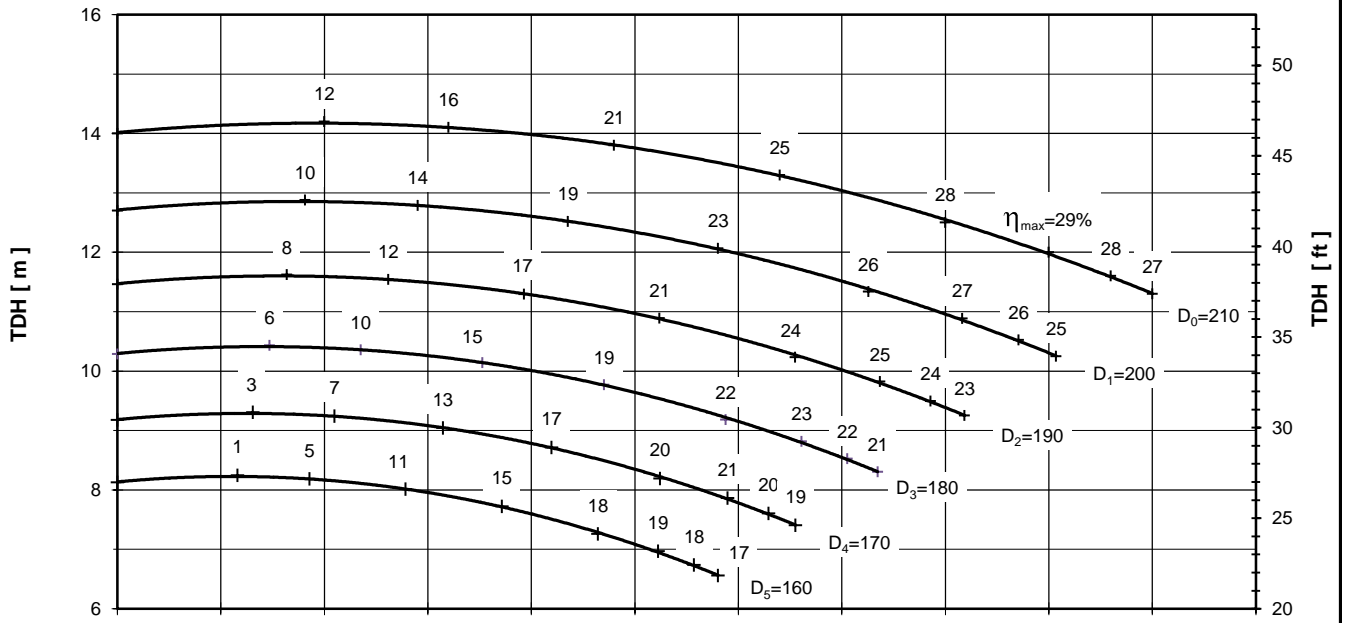

Performance curves are valid for clean cold water-kinematic viscosity 1 [mm²/s], density 1000 [kg/m³]. Methods and tolerances of presented performance curves are in accordance with ISO 9906 - Annex A



PUMP PERFORMANCE CURVES  
No. 4HD.0142.03

PUMP TYPE  
SCP 32 - 160  
1450 [rpm]

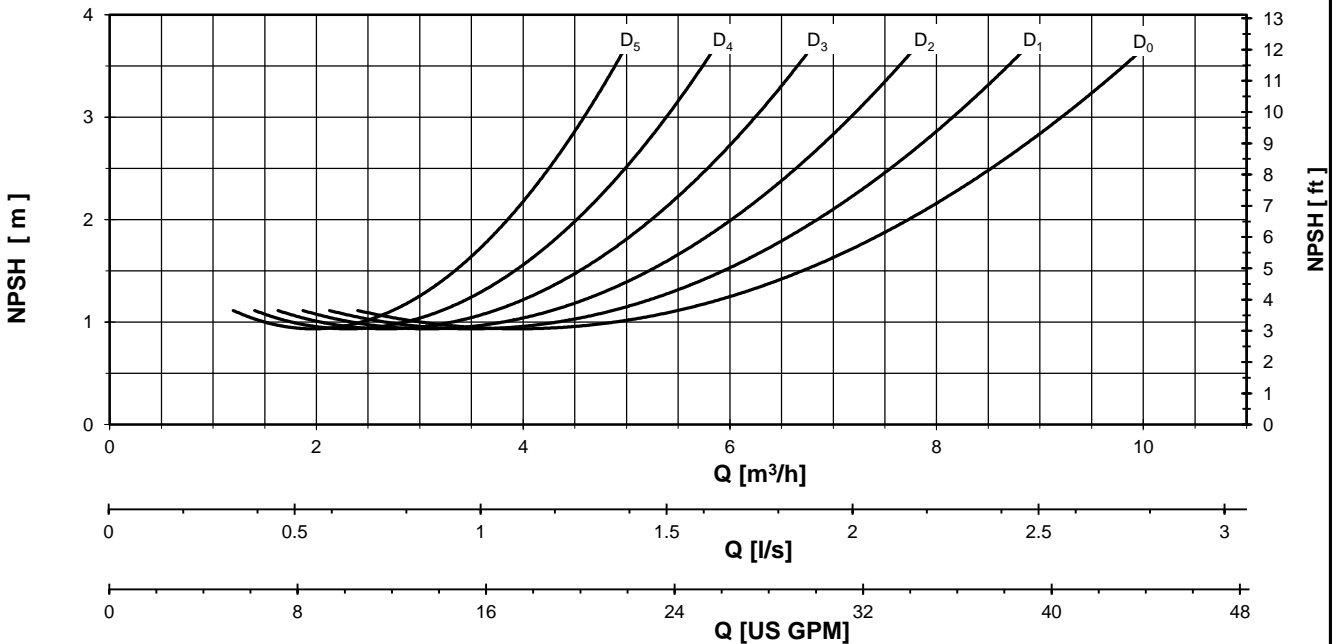
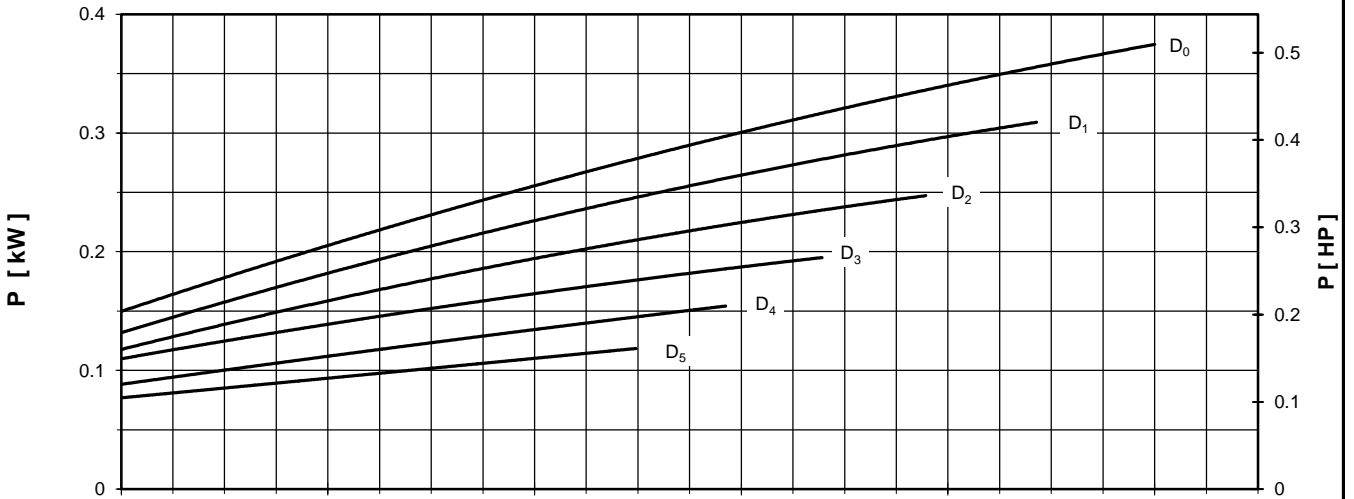
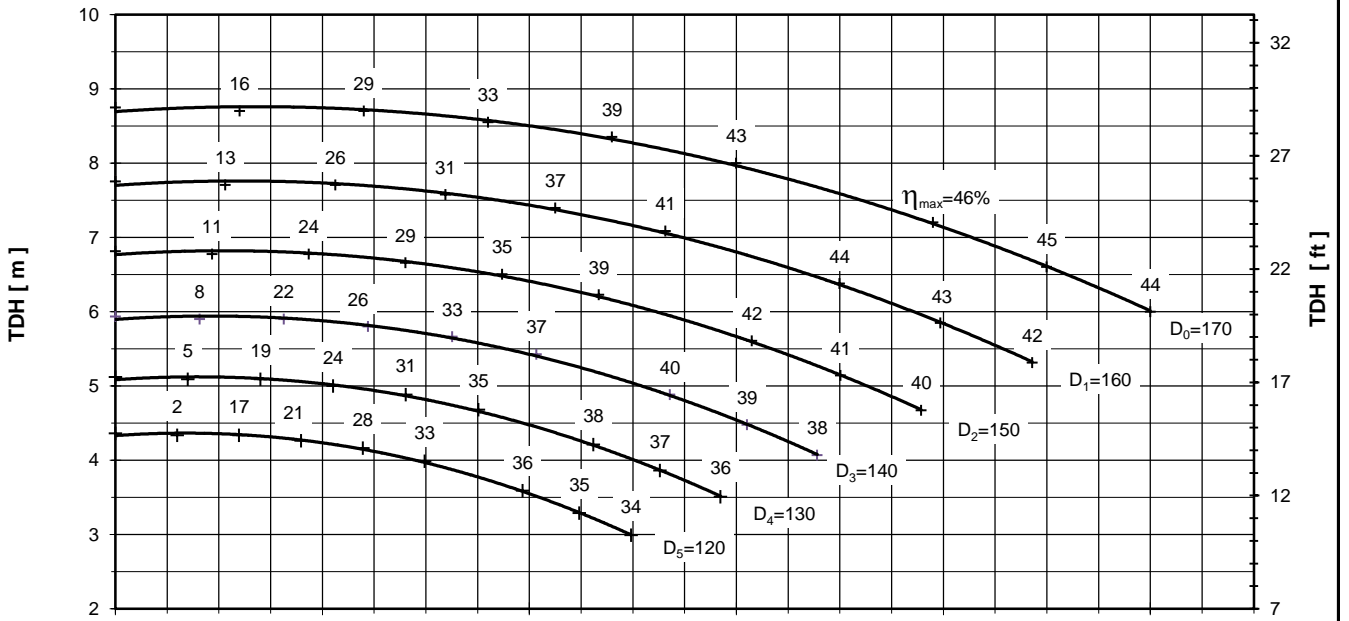

Performance curves are valid for clean cold water-kinematic viscosity 1 [mm²/s], density 1000 [kg/m³]. Methods and tolerances of presented performance curves are in accordance with ISO 9906 - Annex A



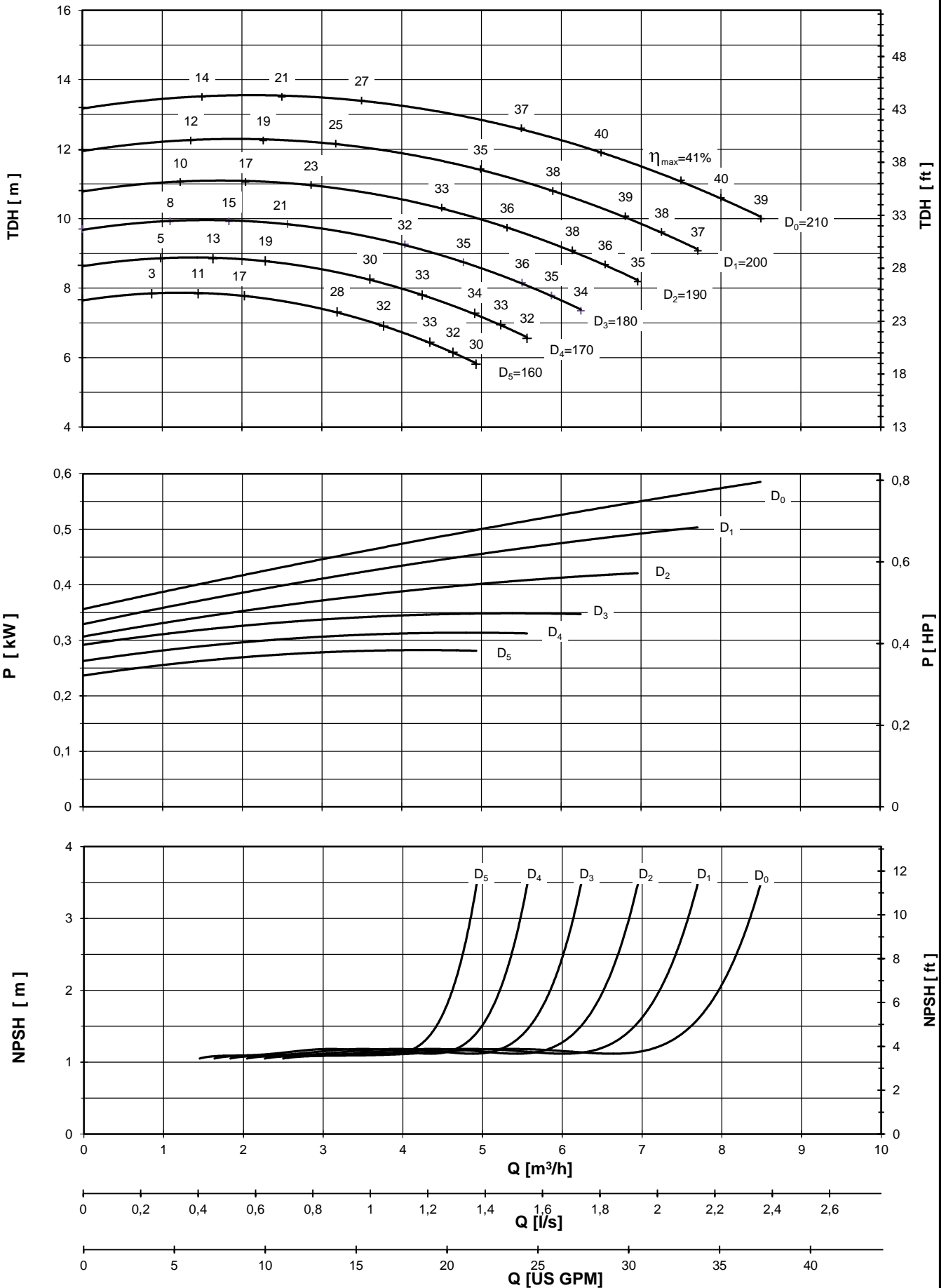

Performance curves are valid for clean cold water-kinematic viscosity 1 [mm<sup>2</sup>/s], density 1000 [kg/m<sup>3</sup>]. Methods and tolerances of presented performance curves are in accordance with ISO 9906 - Annex A

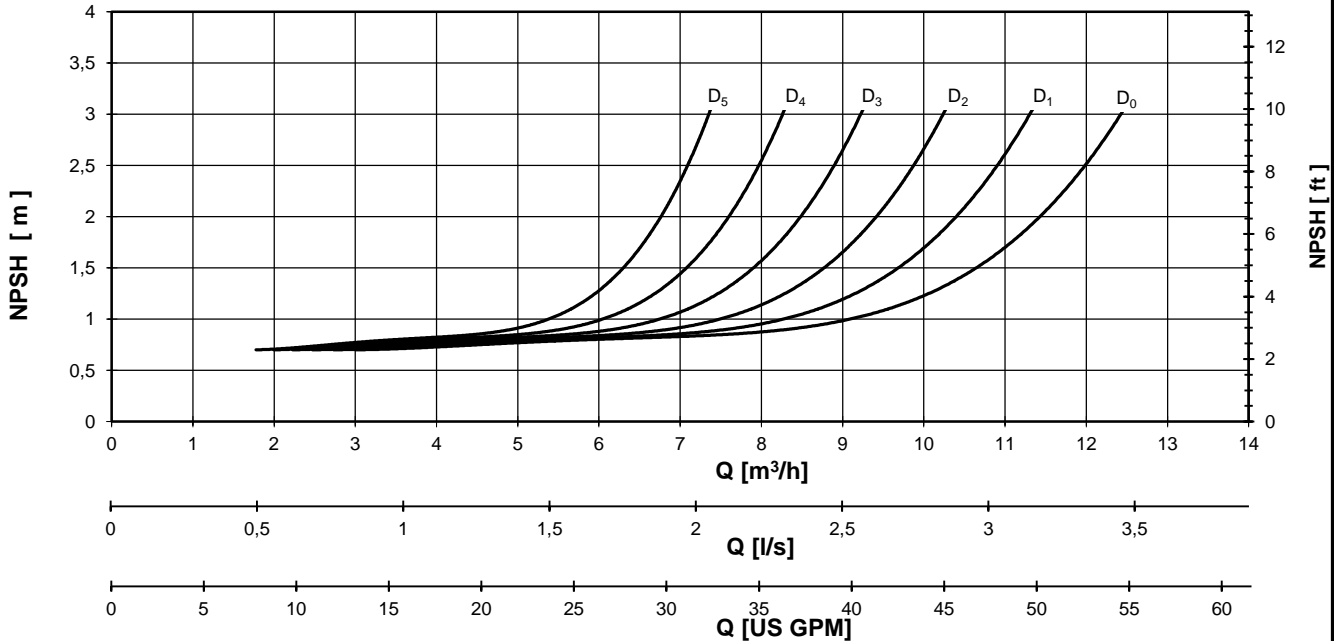
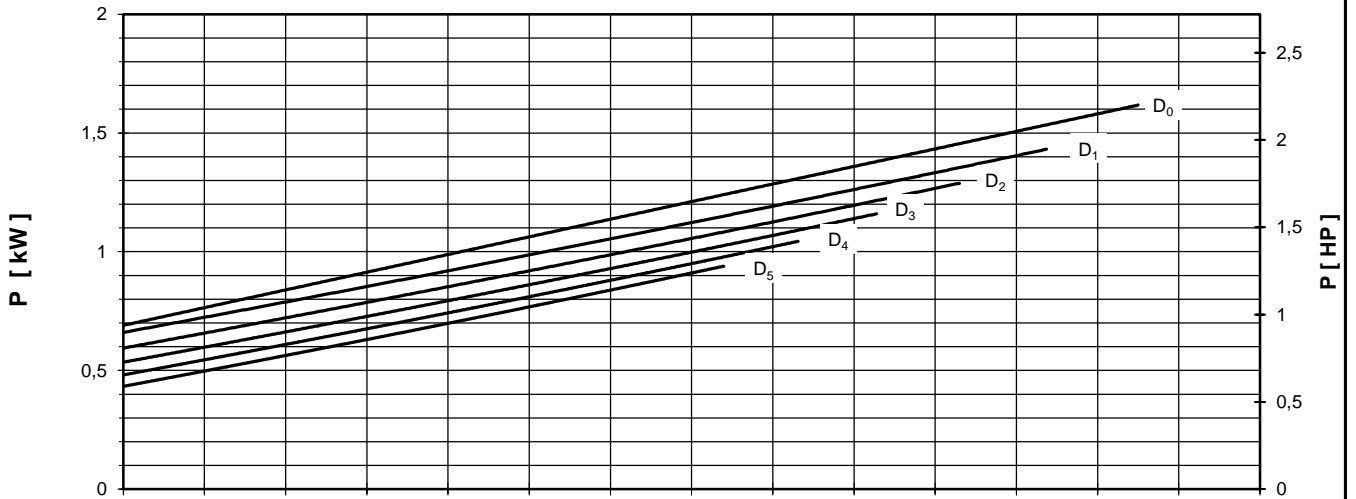
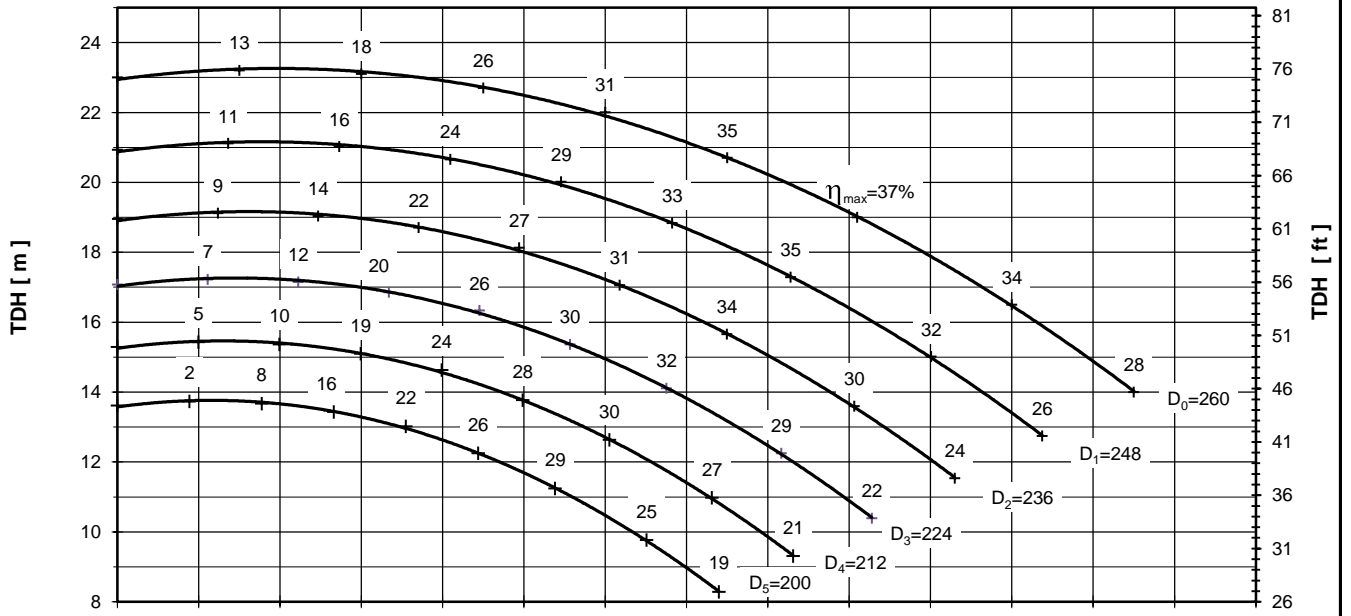

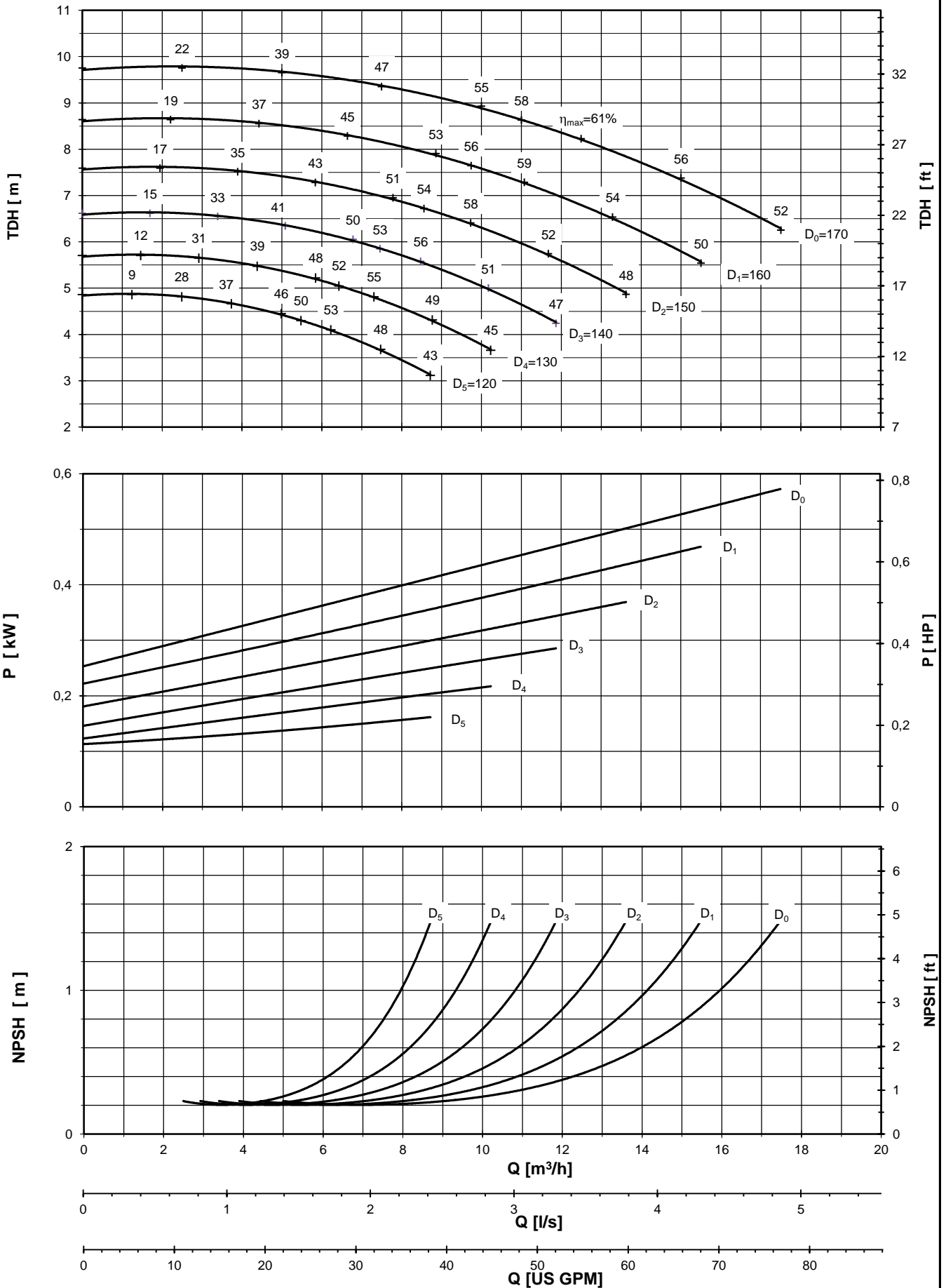

Performance curves are valid for clean cold water-kinematic viscosity 1 [mm<sup>2</sup>/s], density 1000 [kg/m<sup>3</sup>]. Methods and tolerances of presented performance curves are in accordance with ISO 9906 - Annex A

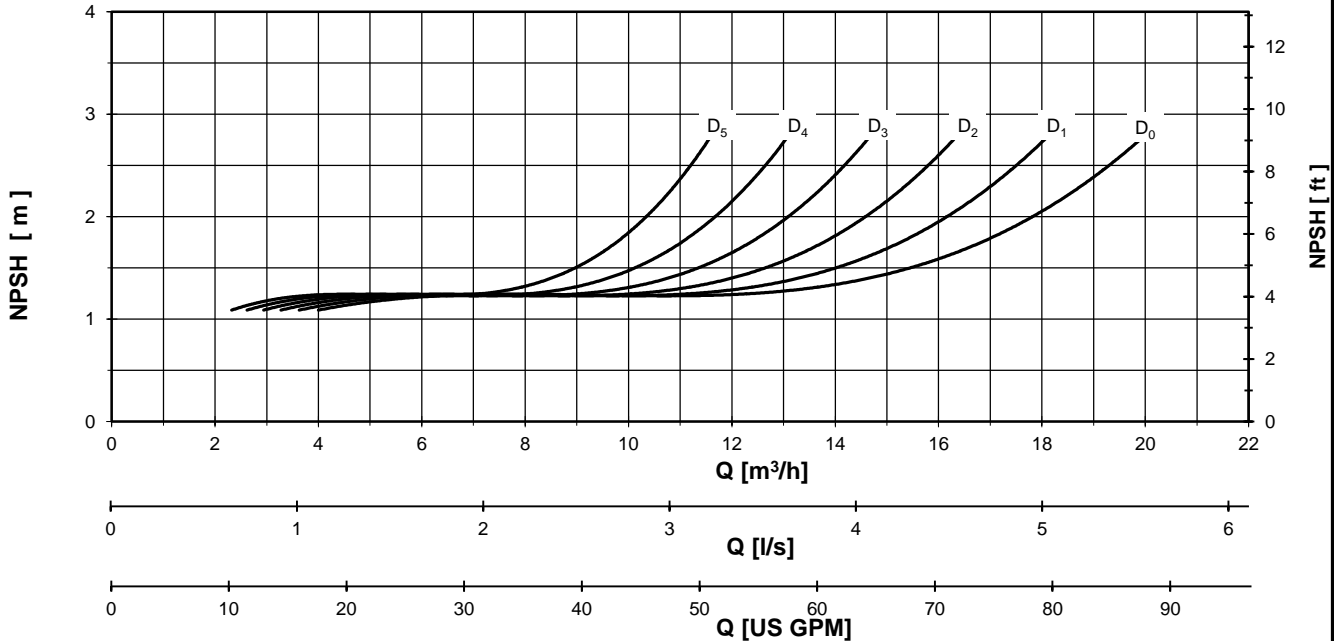
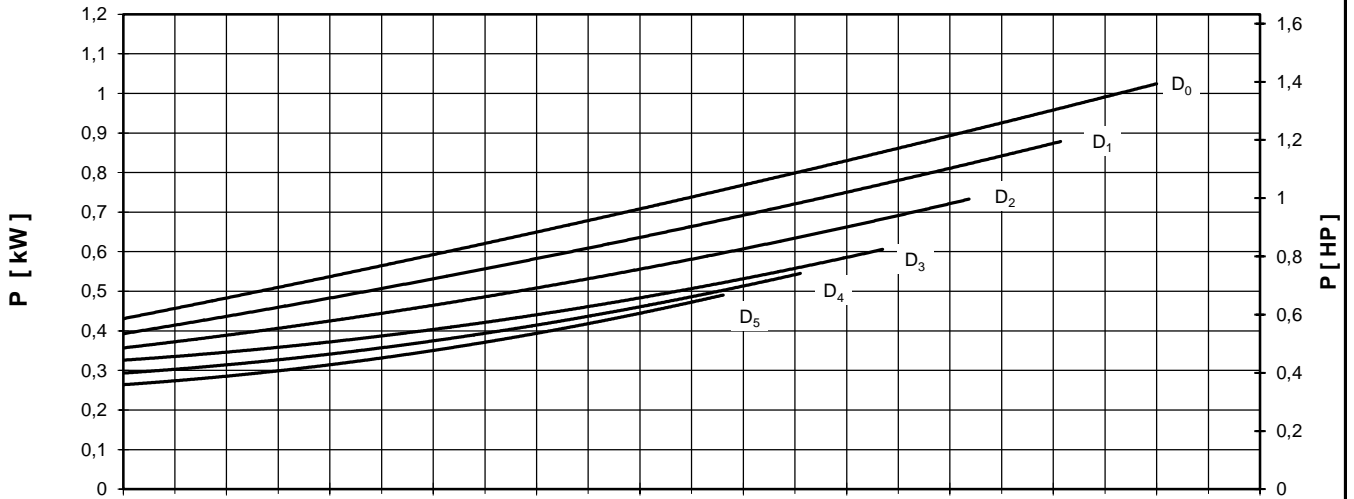
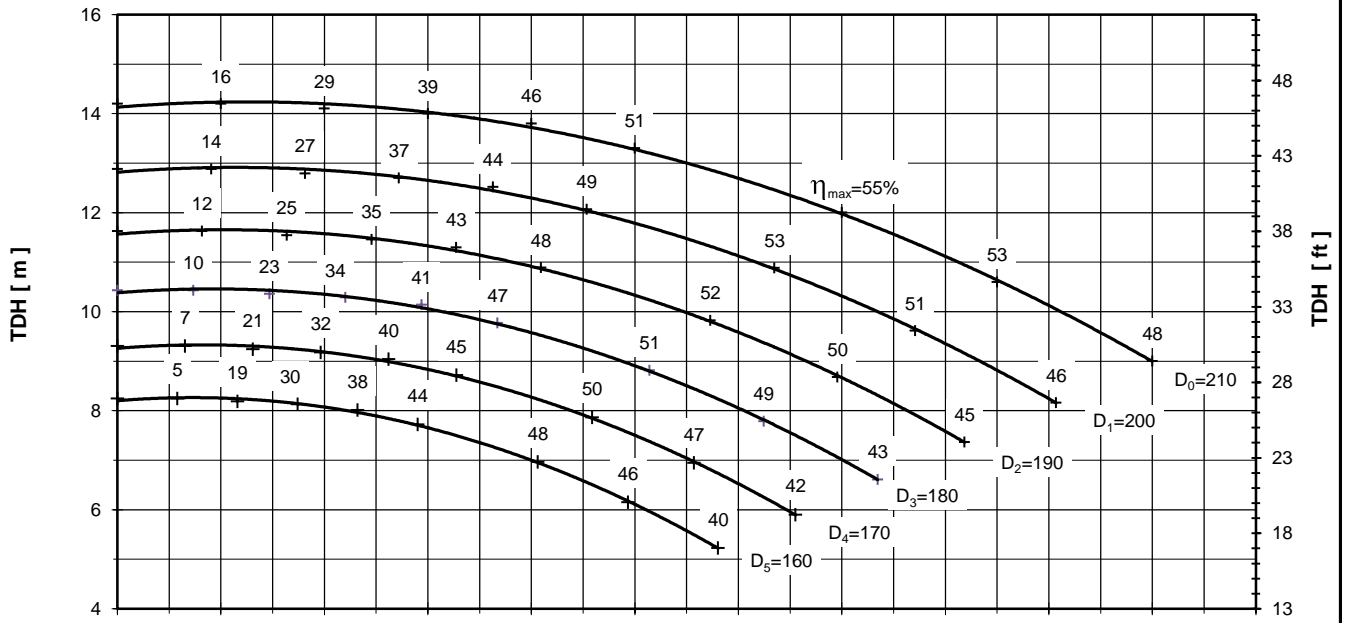



PUMP PERFORMANCE CURVES  
No. 4HS.0148.03

PUMP TYPE  
SCP 40 - 250  
1450 [rpm]

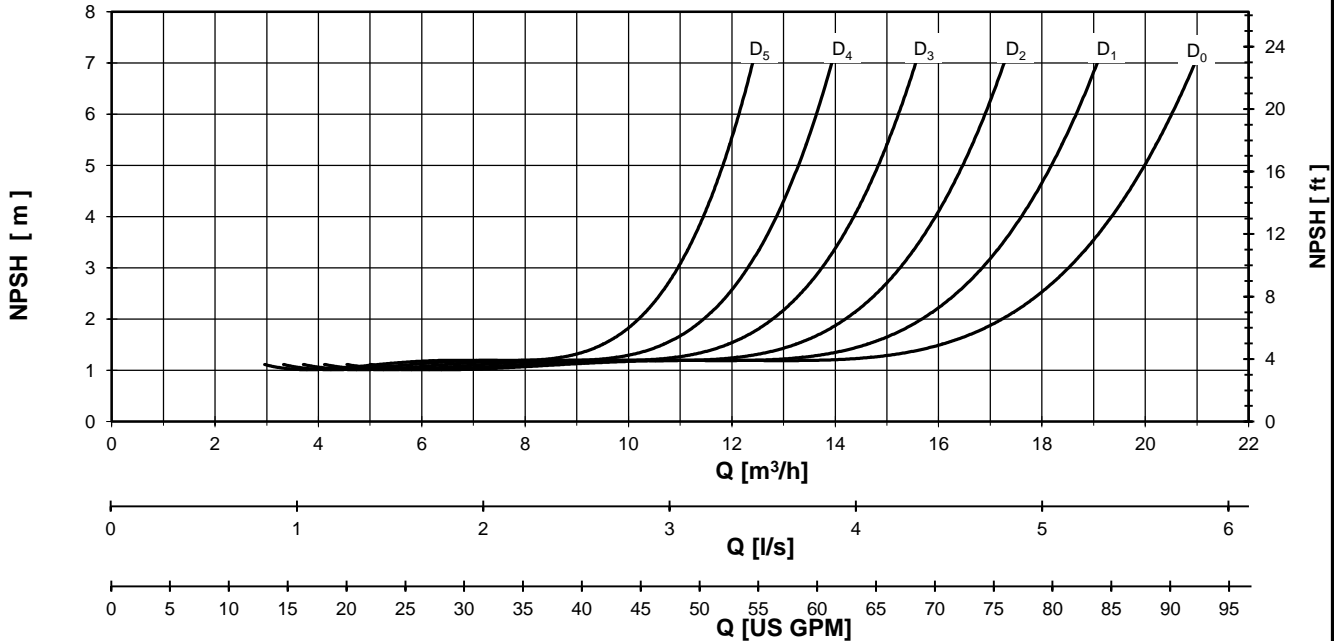
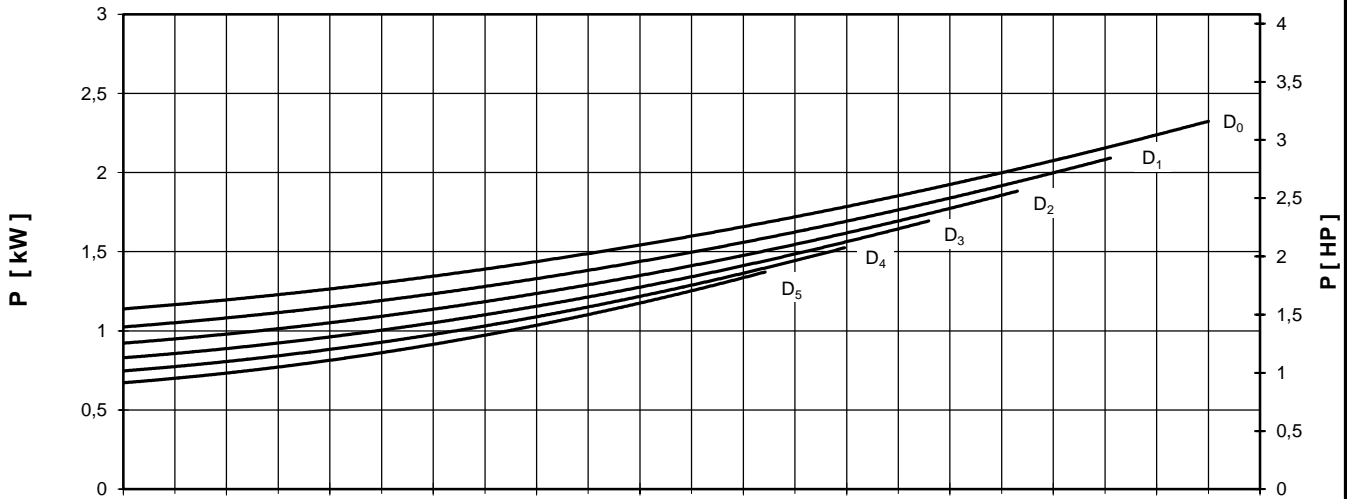
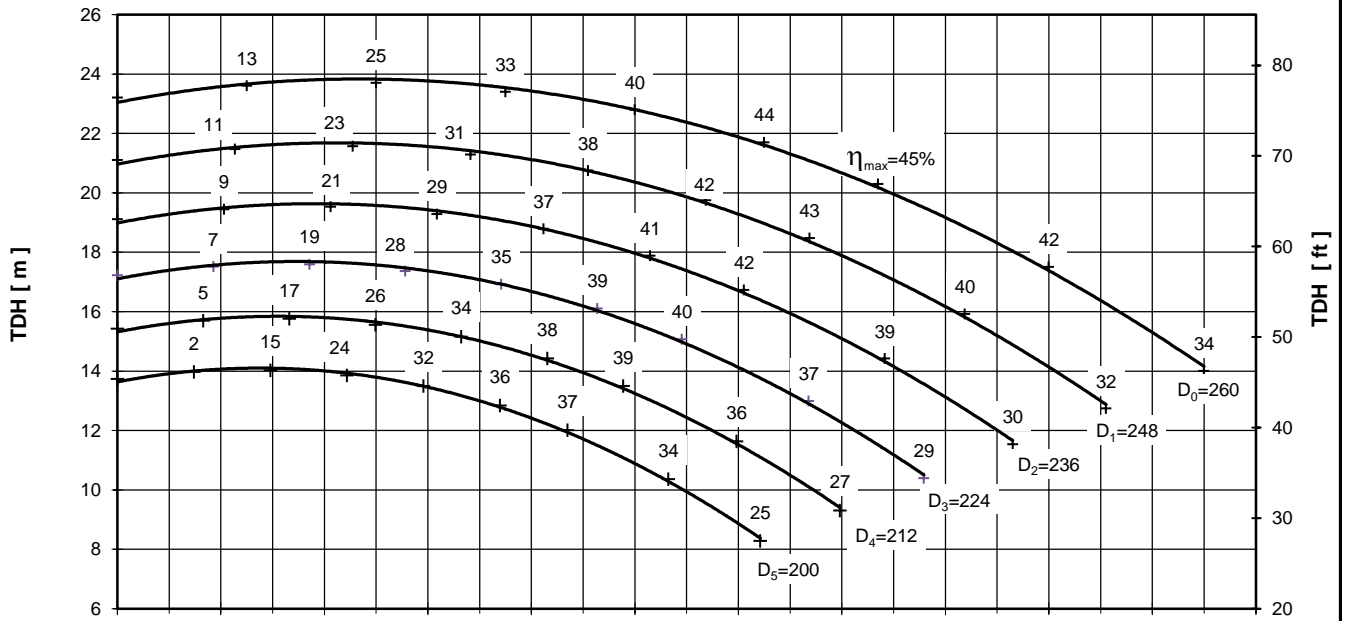

Performance curves are valid for clean cold water-kinematic viscosity 1 [mm²/s], density 1000 [kg/m³]. Methods and tolerances of presented performance curves are in accordance with ISO 9906 - Annex A



PUMP PERFORMANCE CURVES  
No. 4HD.0149.03

PUMP TYPE  
SCP 40 - 315  
1450 [rpm]

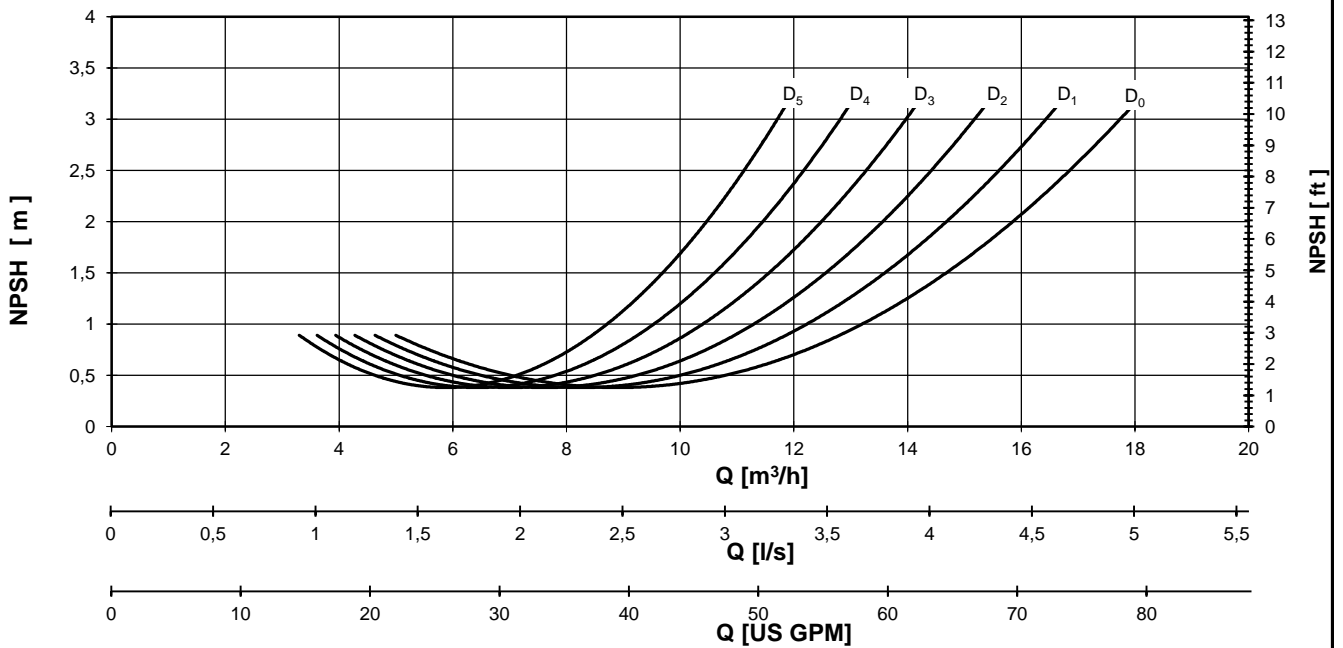
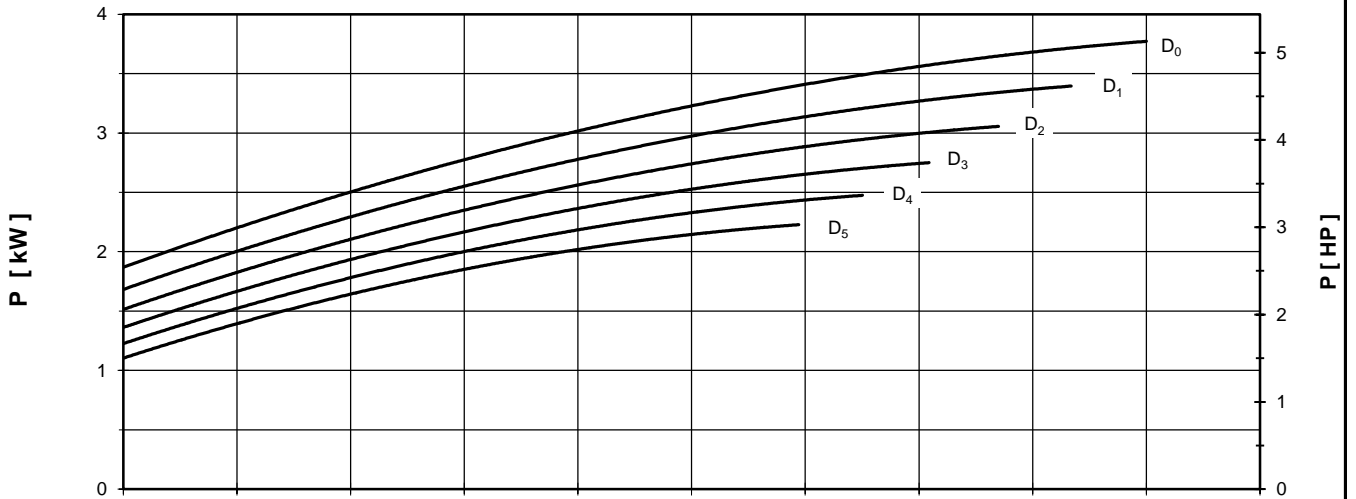
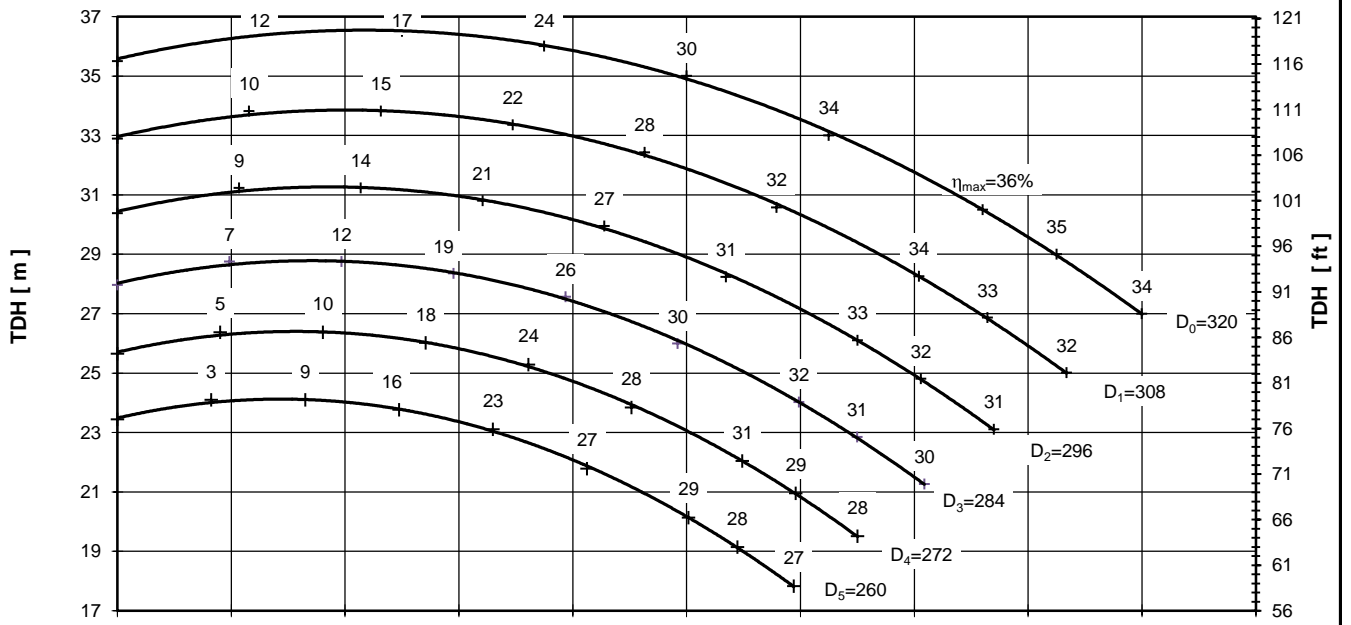

Performance curves are valid for clean cold water-kinematic viscosity 1 [mm²/s], density 1000 [kg/m³]. Methods and tolerances of presented performance curves are in accordance with ISO 9906 - Annex A

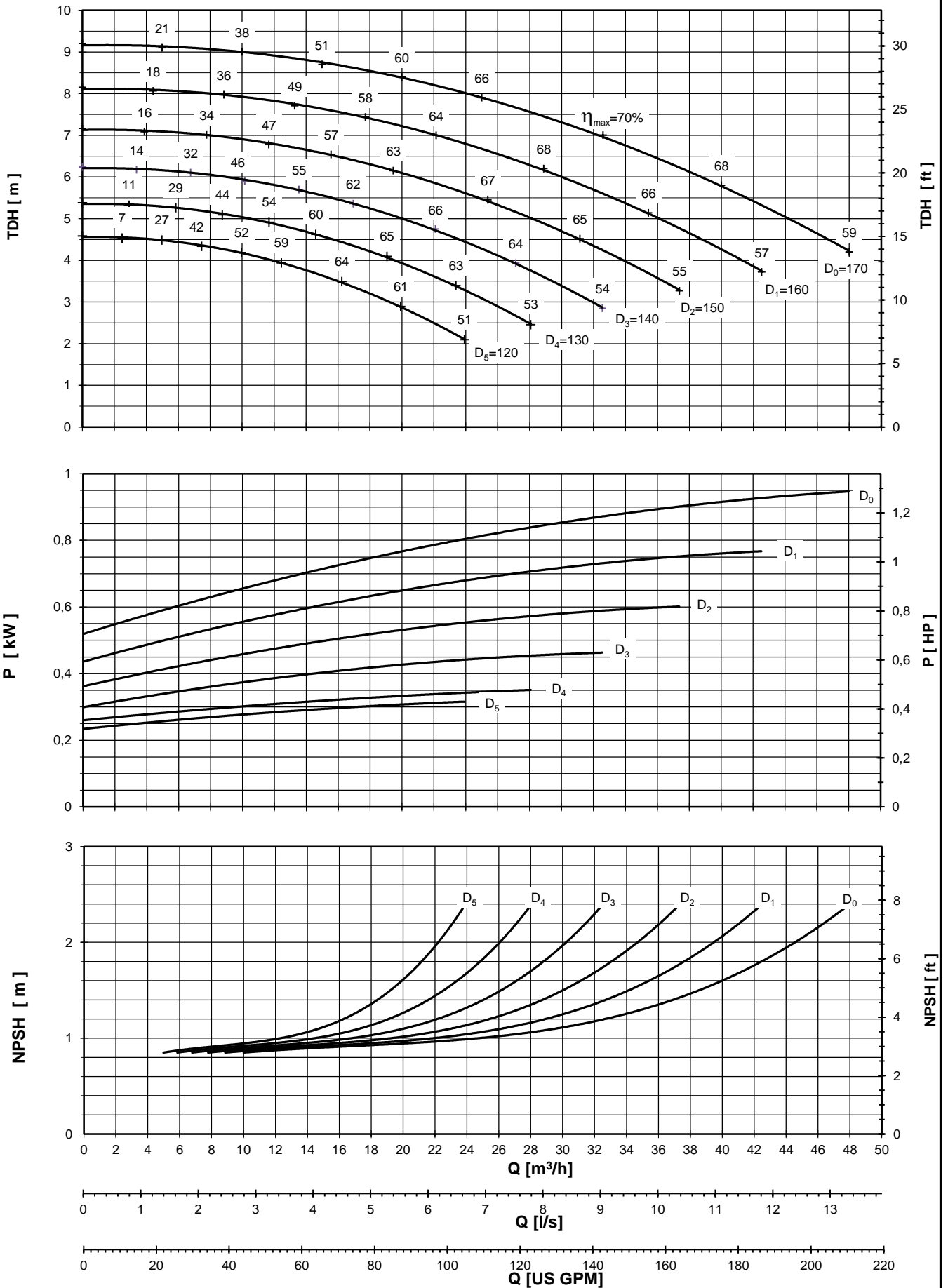

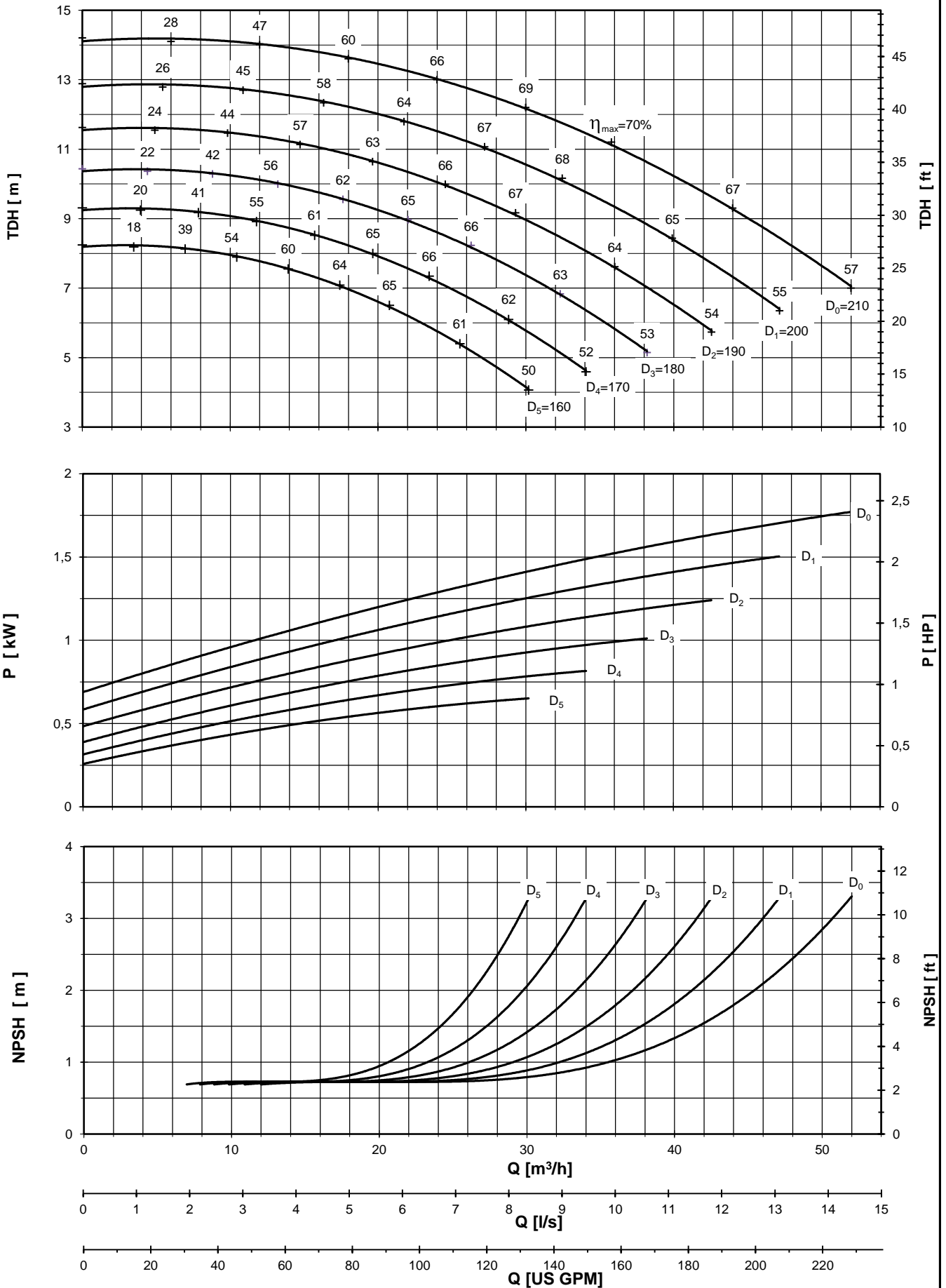

Performance curves are valid for clean cold water-kinematic viscosity 1 [mm<sup>2</sup>/s], density 1000 [kg/m<sup>3</sup>]. Methods and tolerances of presented performance curves are in accordance with ISO 9906 - Annex A





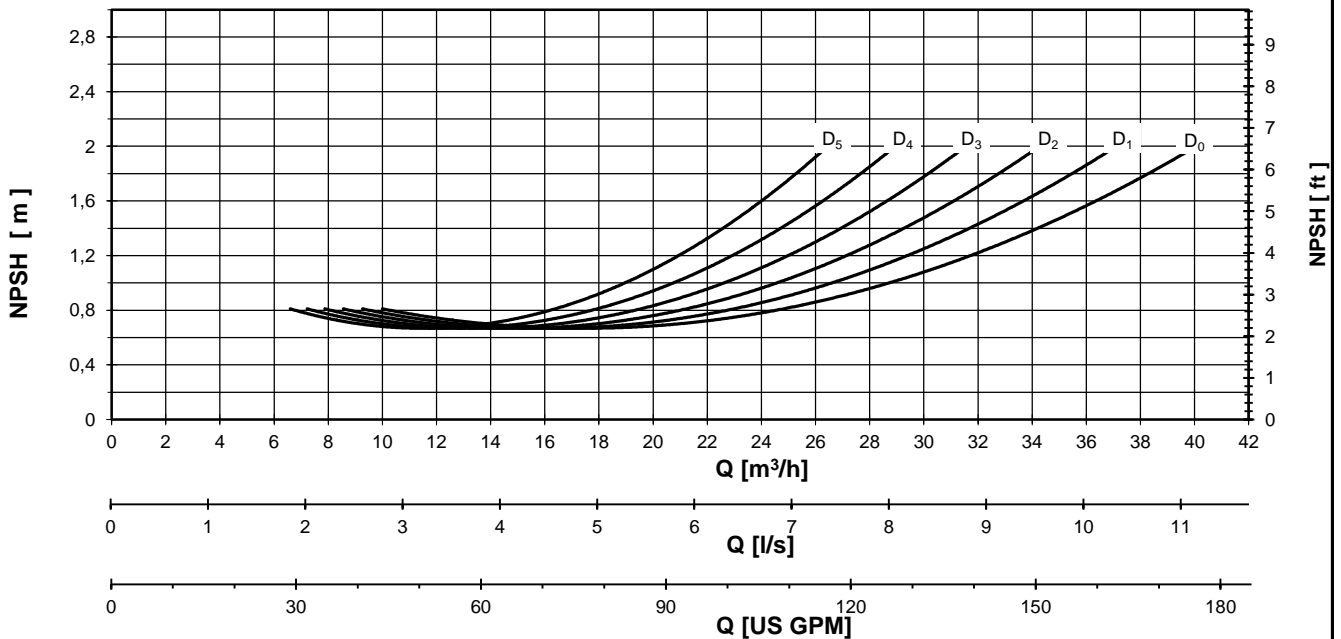
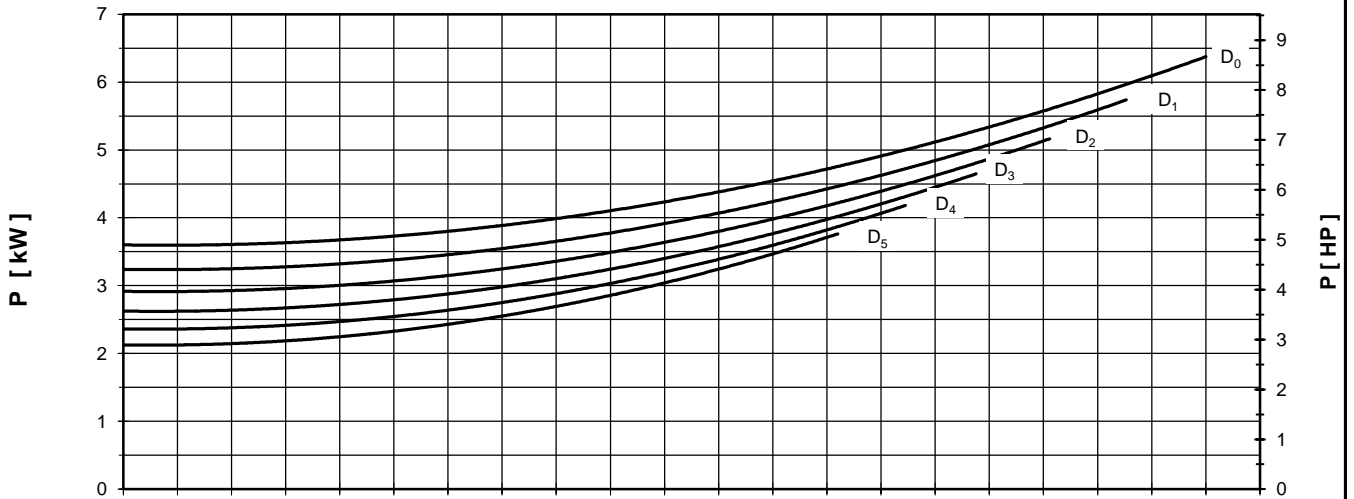
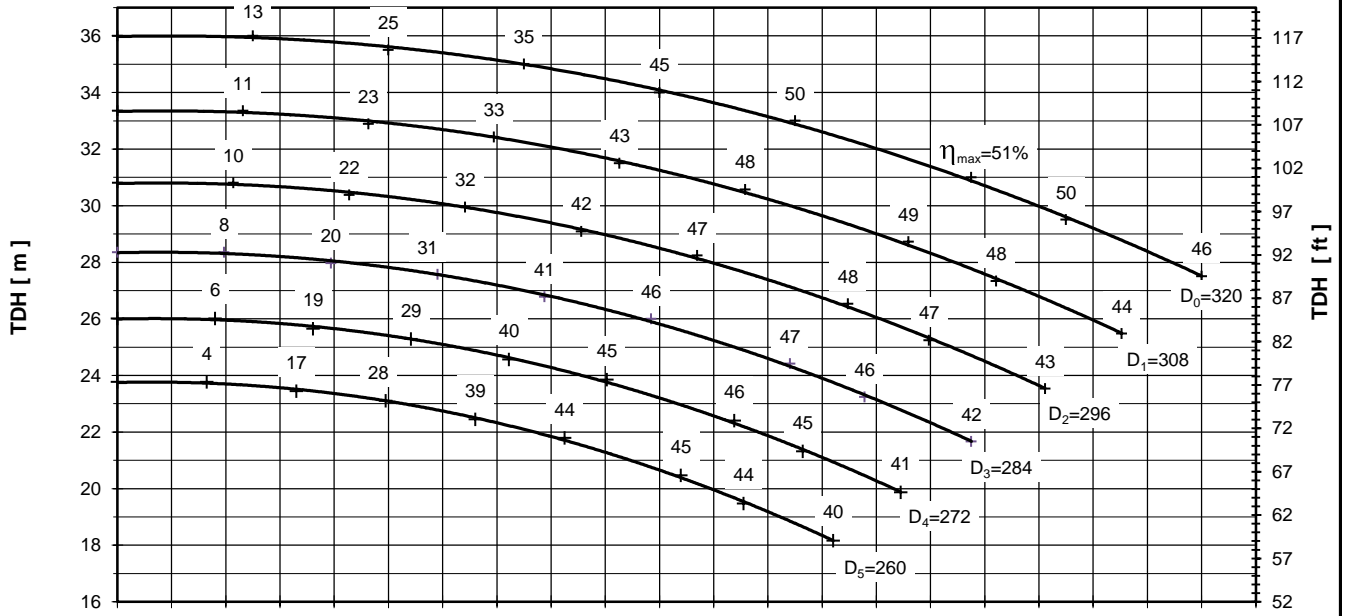

Performance curves are valid for clean cold water-kinematic viscosity 1 [mm²/s], density 1000 [kg/m³]. Methods and tolerances of presented performance curves are in accordance with ISO 9906 - Annex A

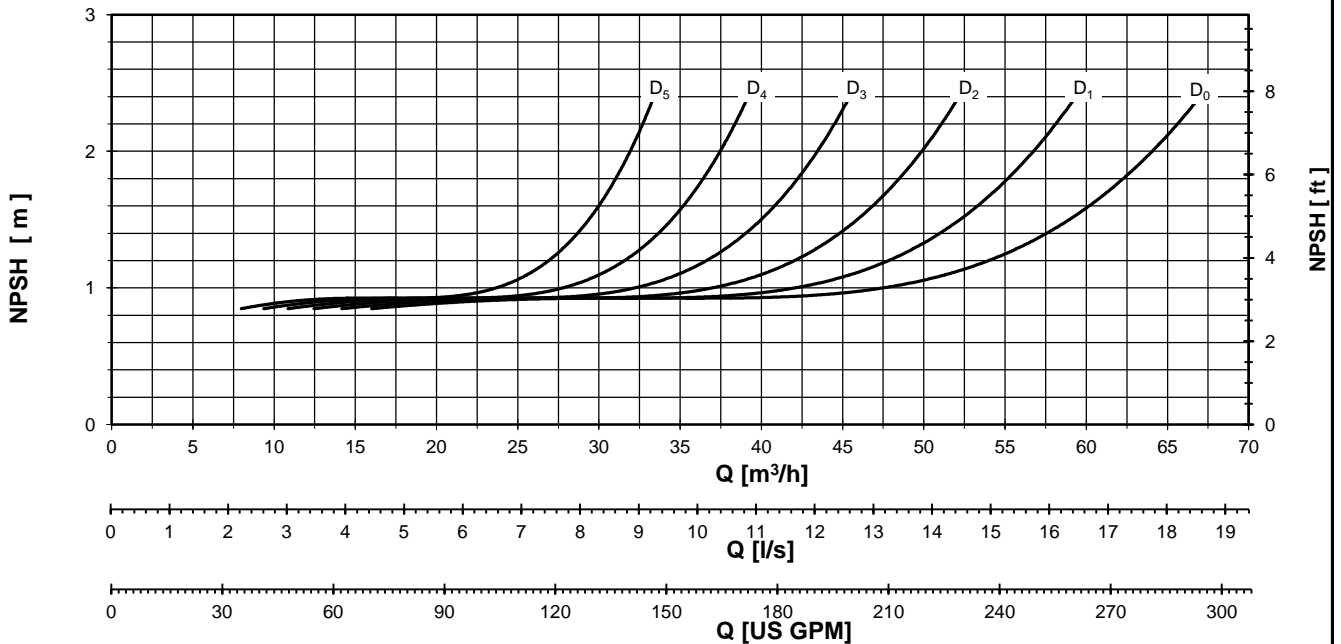
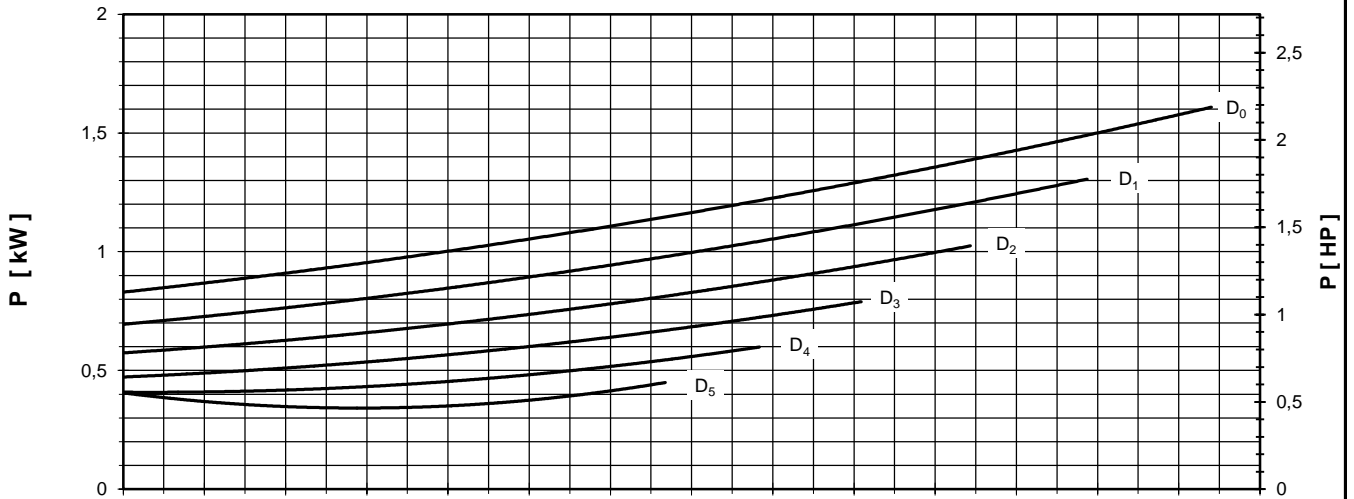
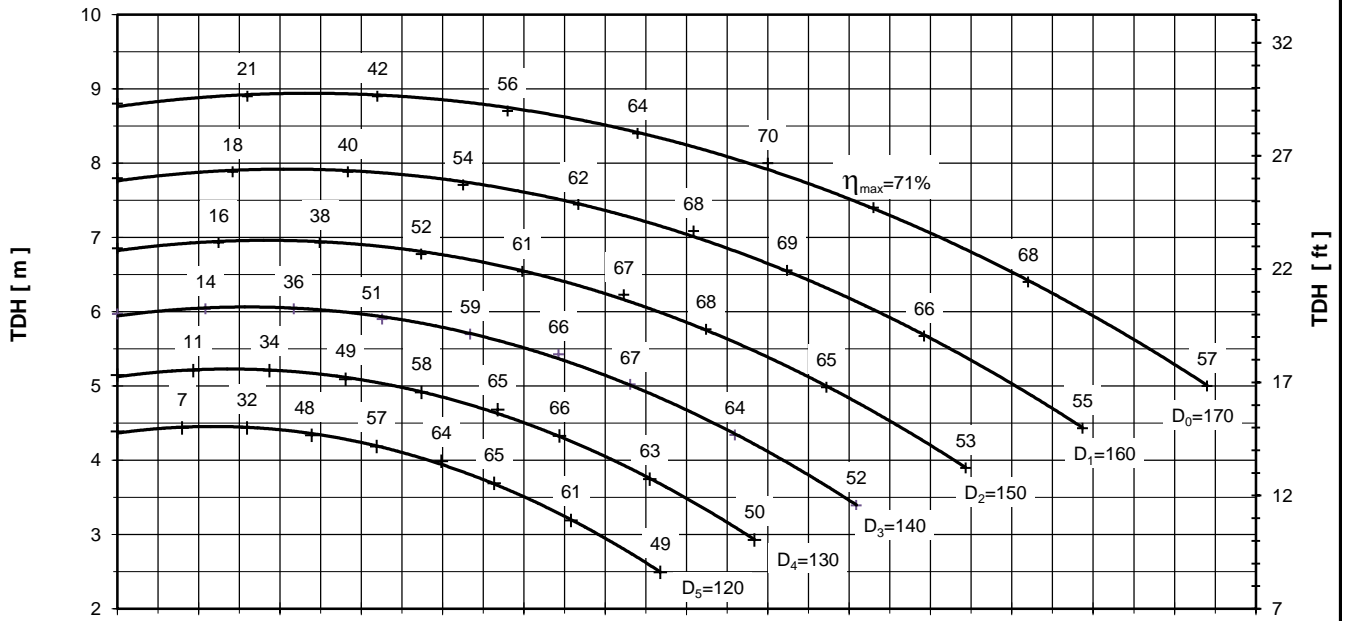

Performance curves are valid for clean cold water-kinematic viscosity 1 [mm²/s], density 1000 [kg/m³]. Methods and tolerances of presented performance curves are in accordance with ISO 9906 - Annex A

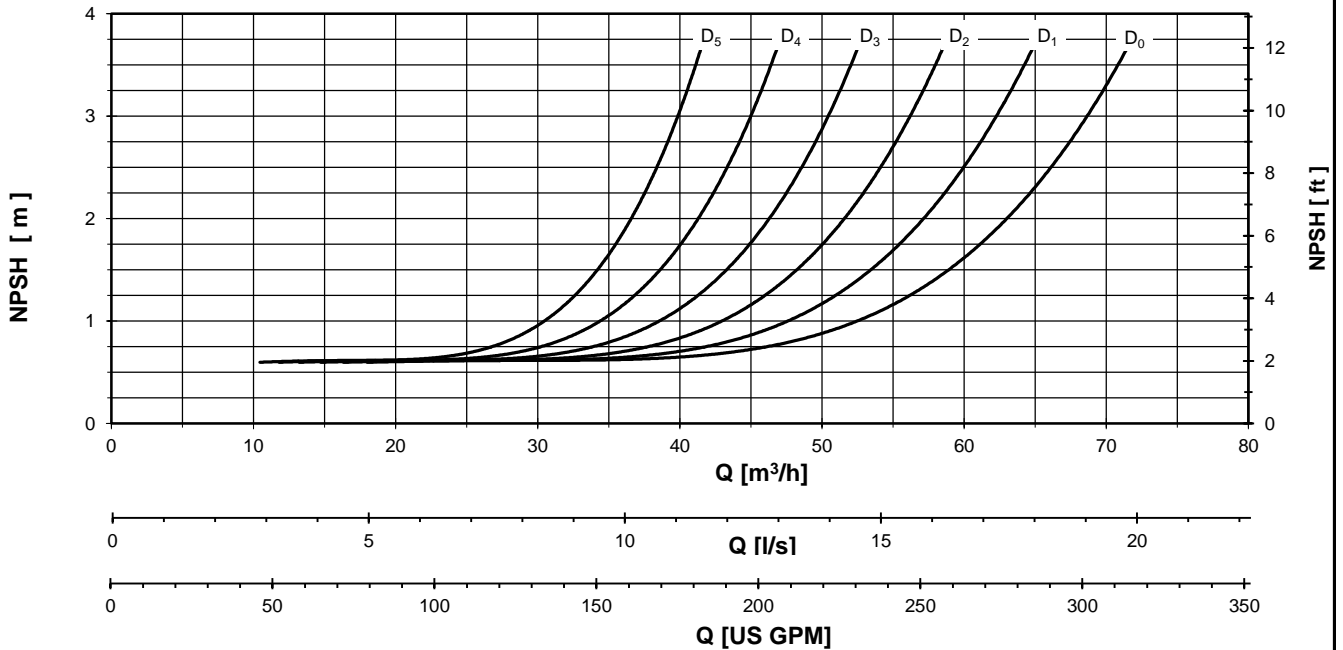
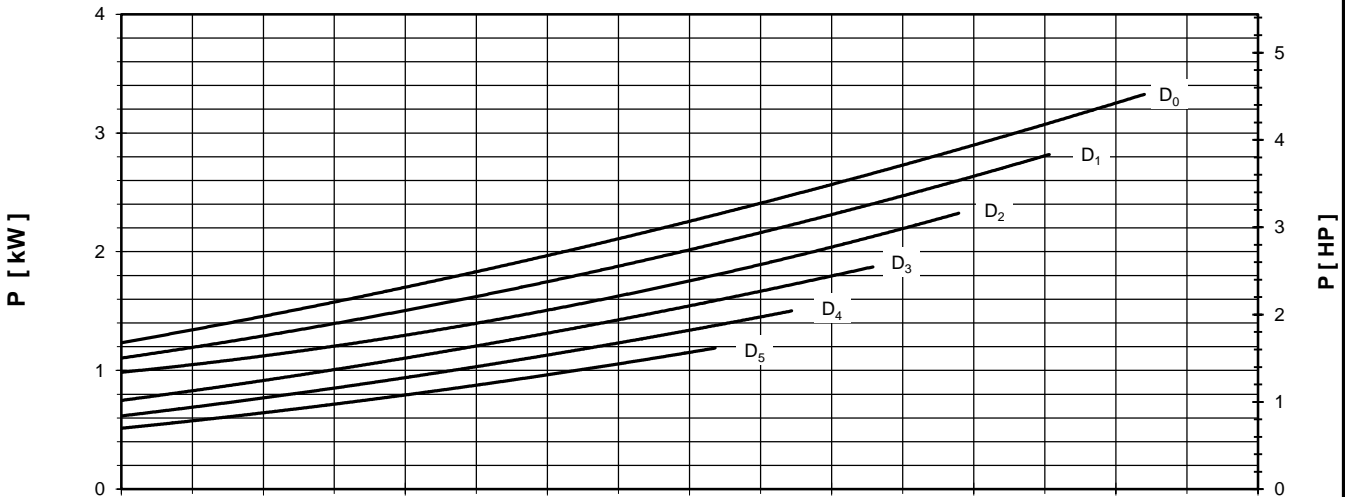
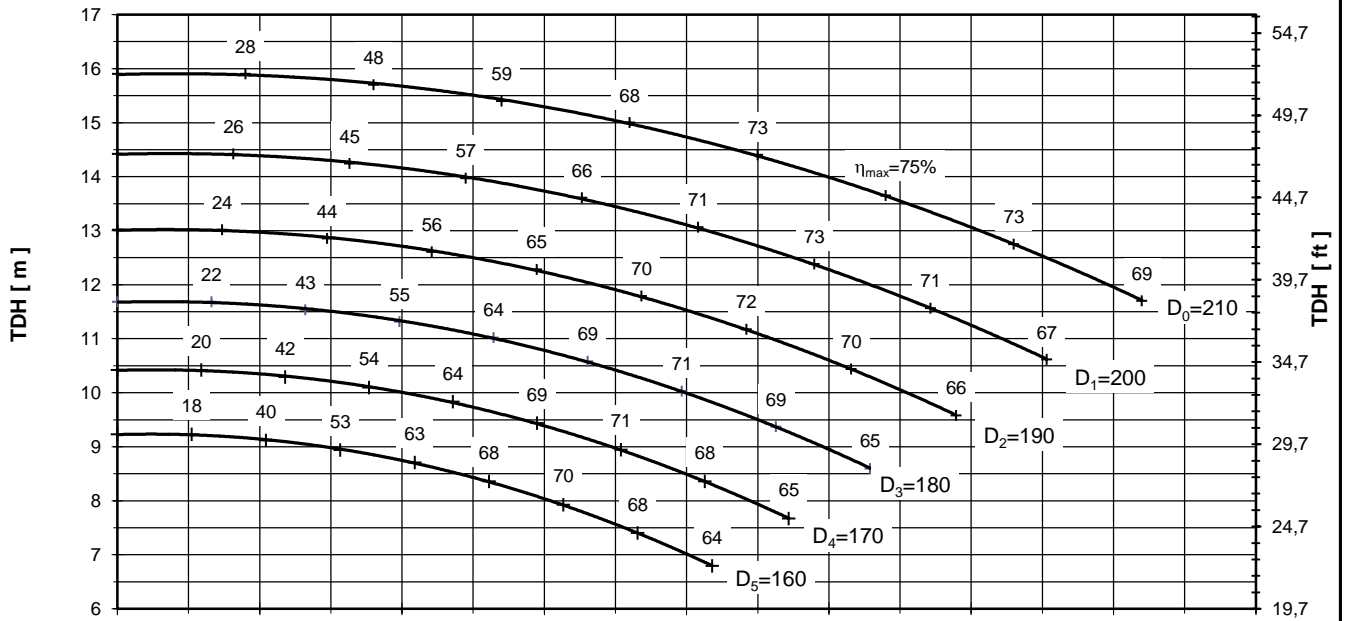

Performance curves are valid for clean cold water-kinematic viscosity 1 [mm<sup>2</sup>/s], density 1000 [kg/m<sup>3</sup>]. Methods and tolerances of presented performance curves are in accordance with ISO 9906 - Annex A

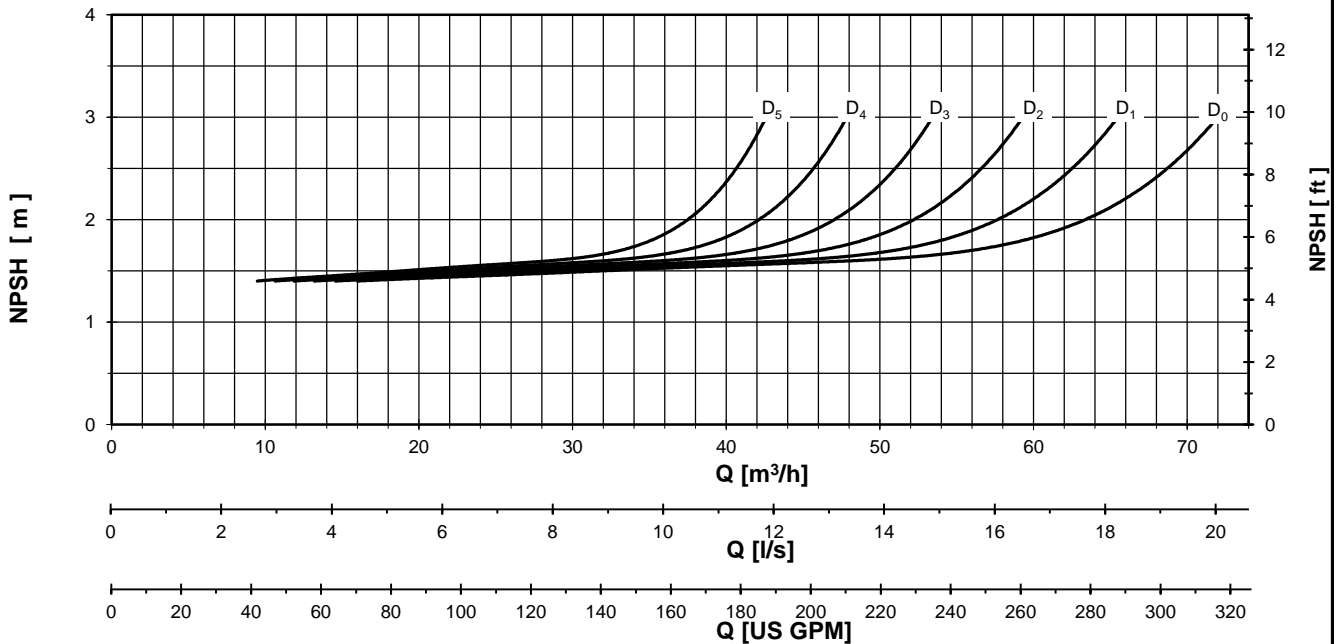
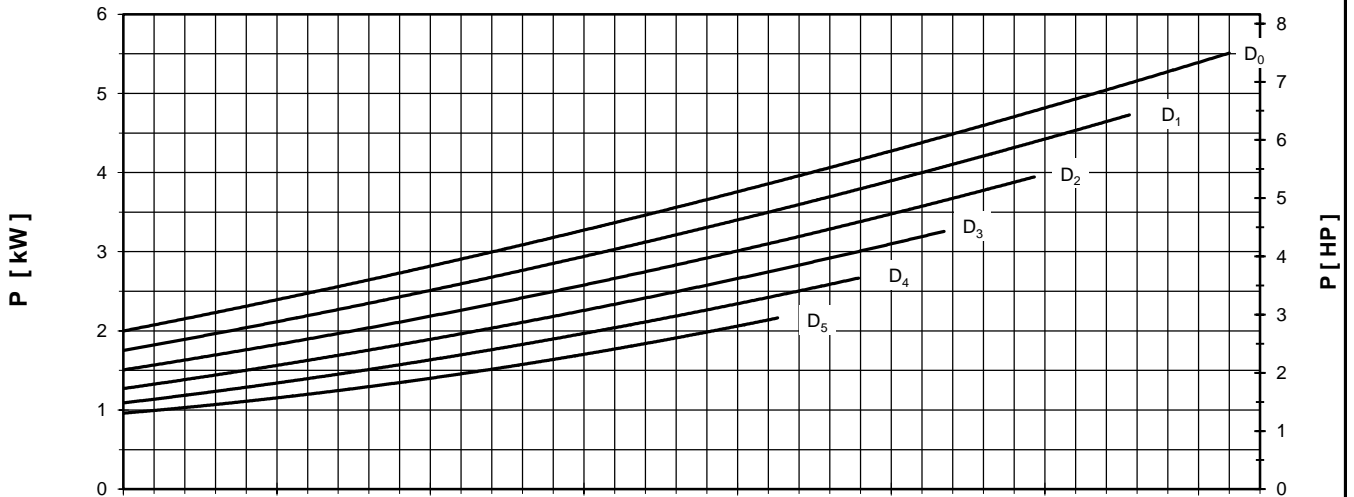
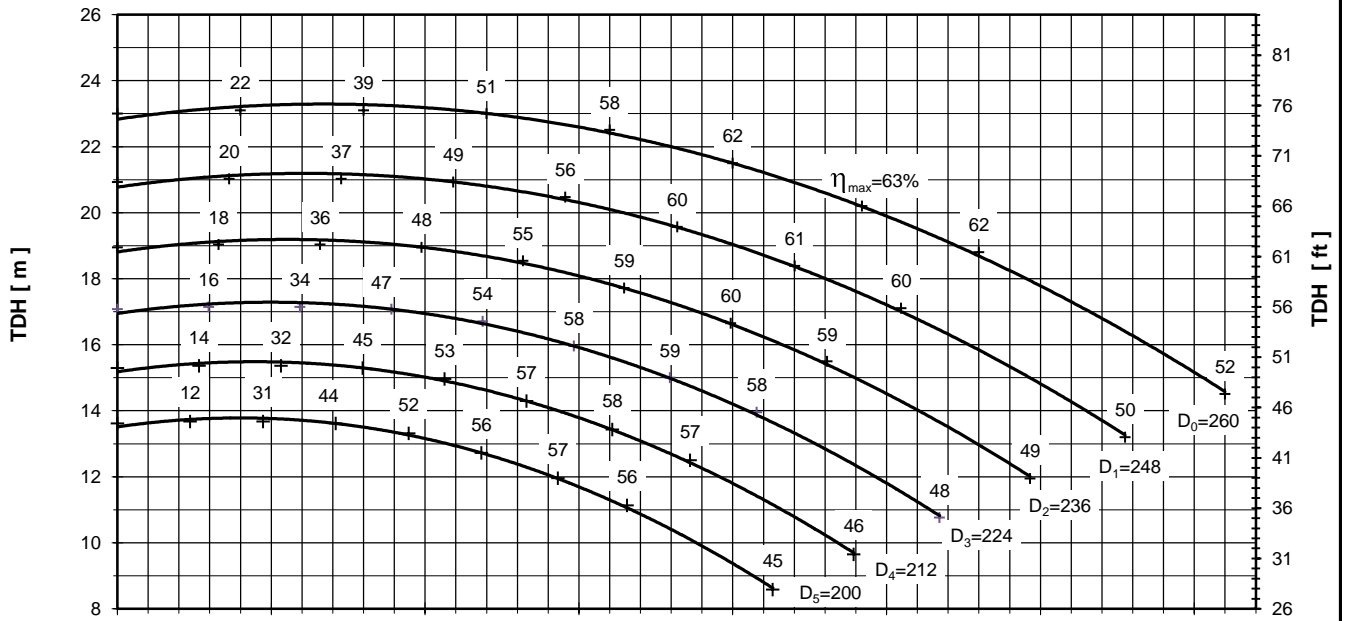

Performance curves are valid for clean cold water-kinematic viscosity 1 [mm²/s], density 1000 [kg/m³]. Methods and tolerances of presented performance curves are in accordance with ISO 9906 - Annex A

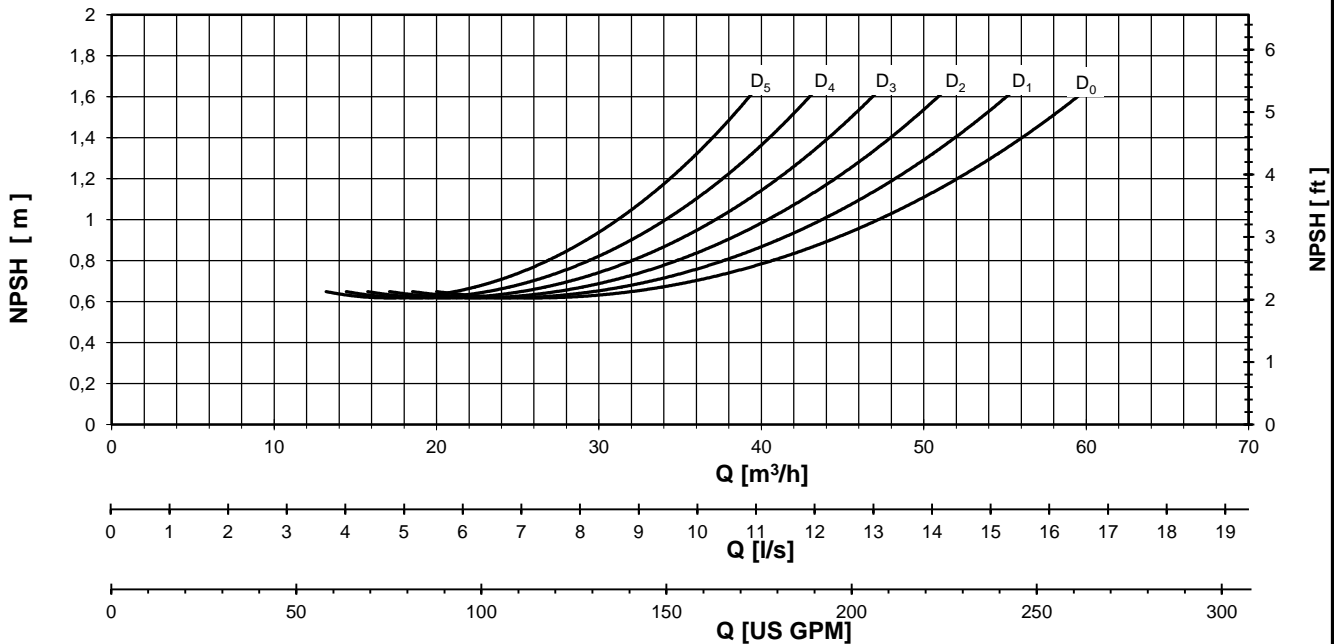
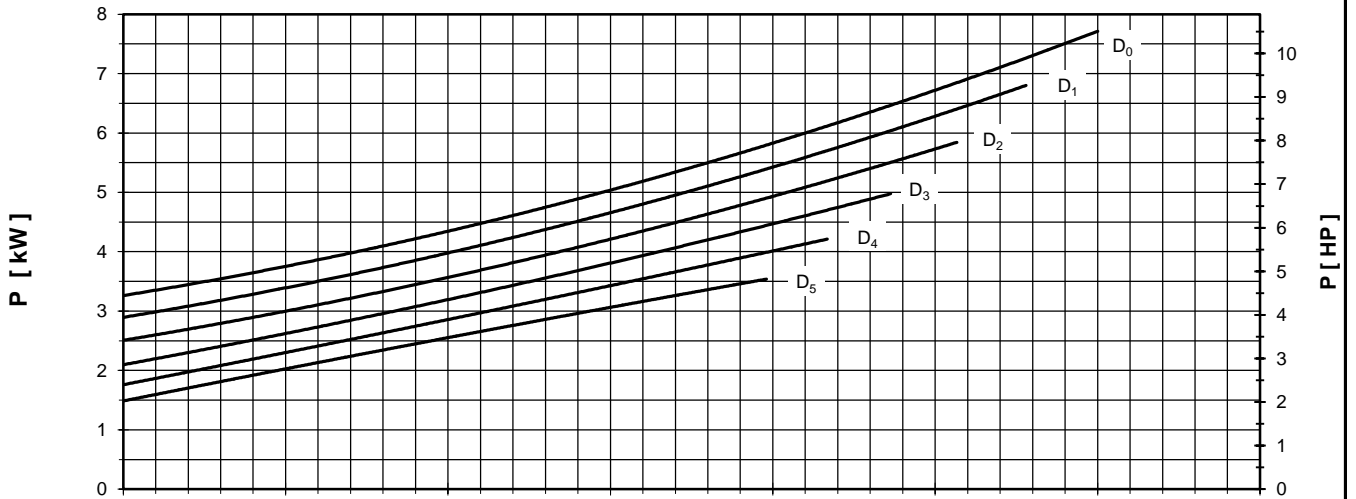
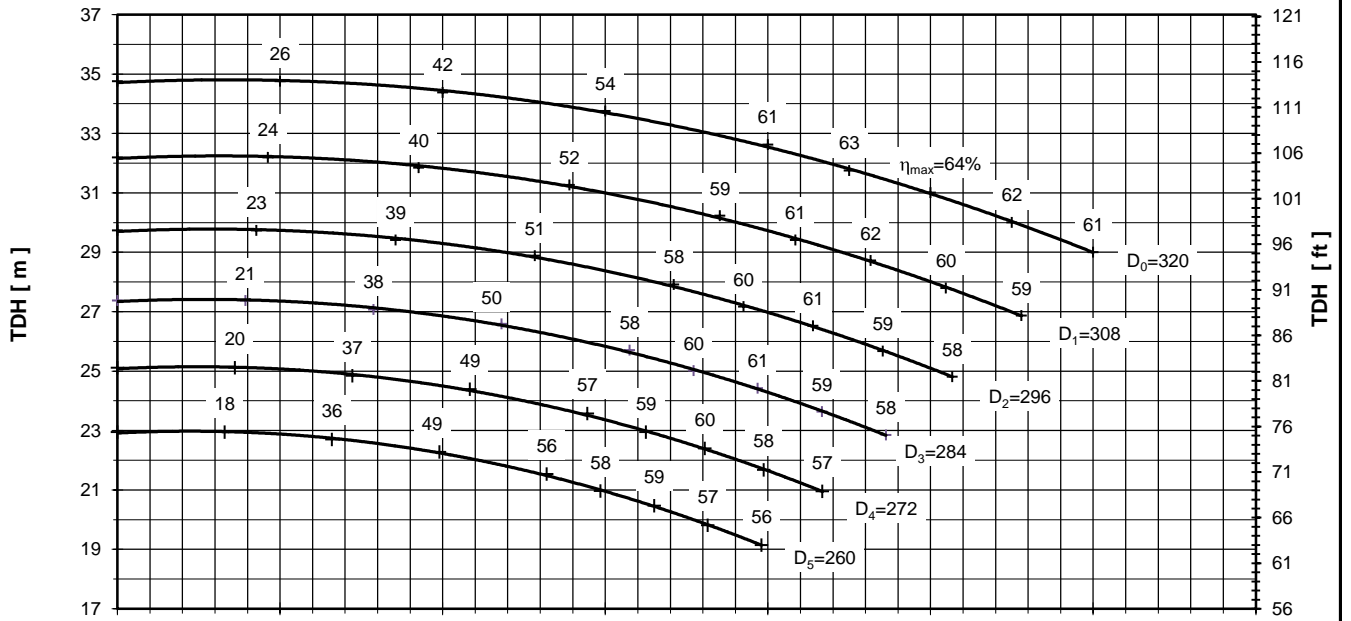



PUMP PERFORMANCE CURVES  
No. 4HD.0160.03

PUMP TYPE  
SCP 80 - 160  
1450 [rpm]

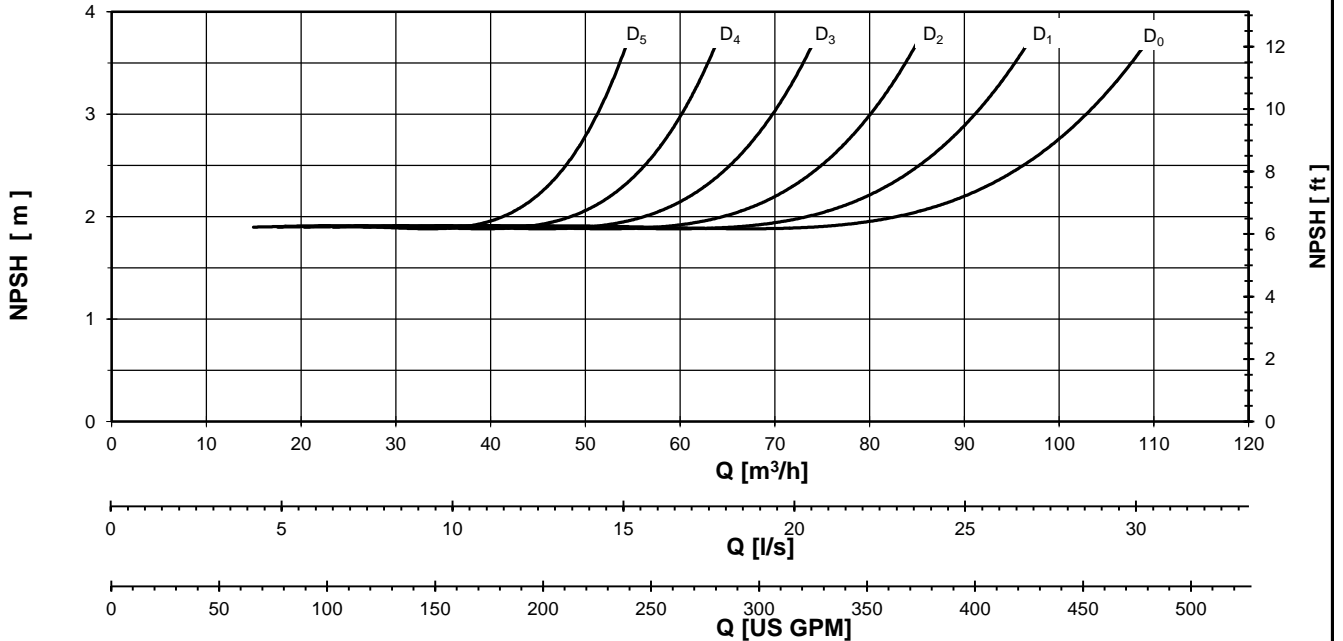
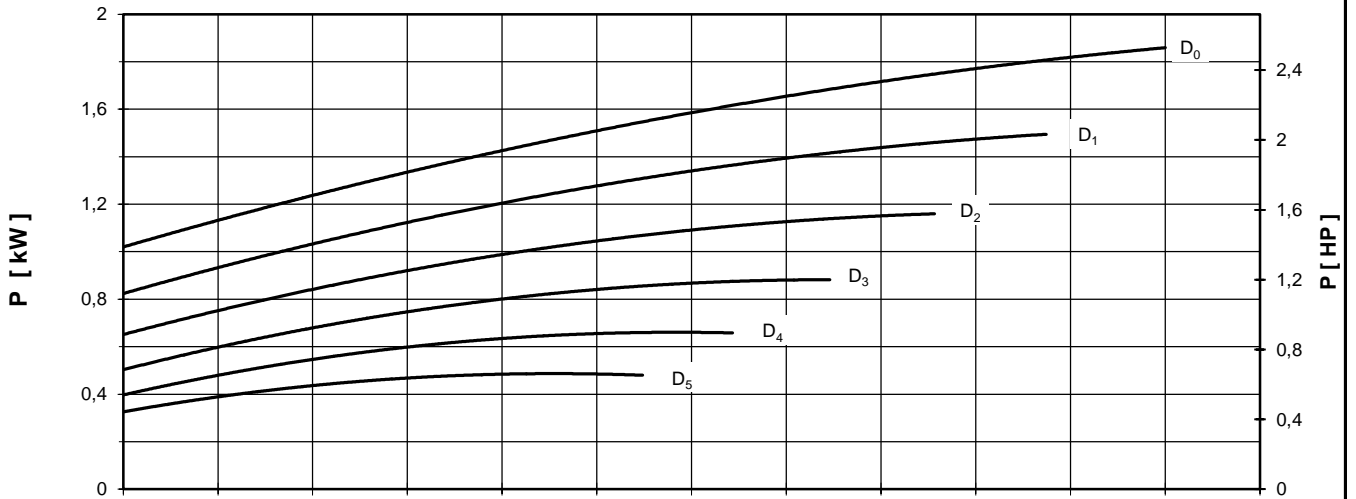
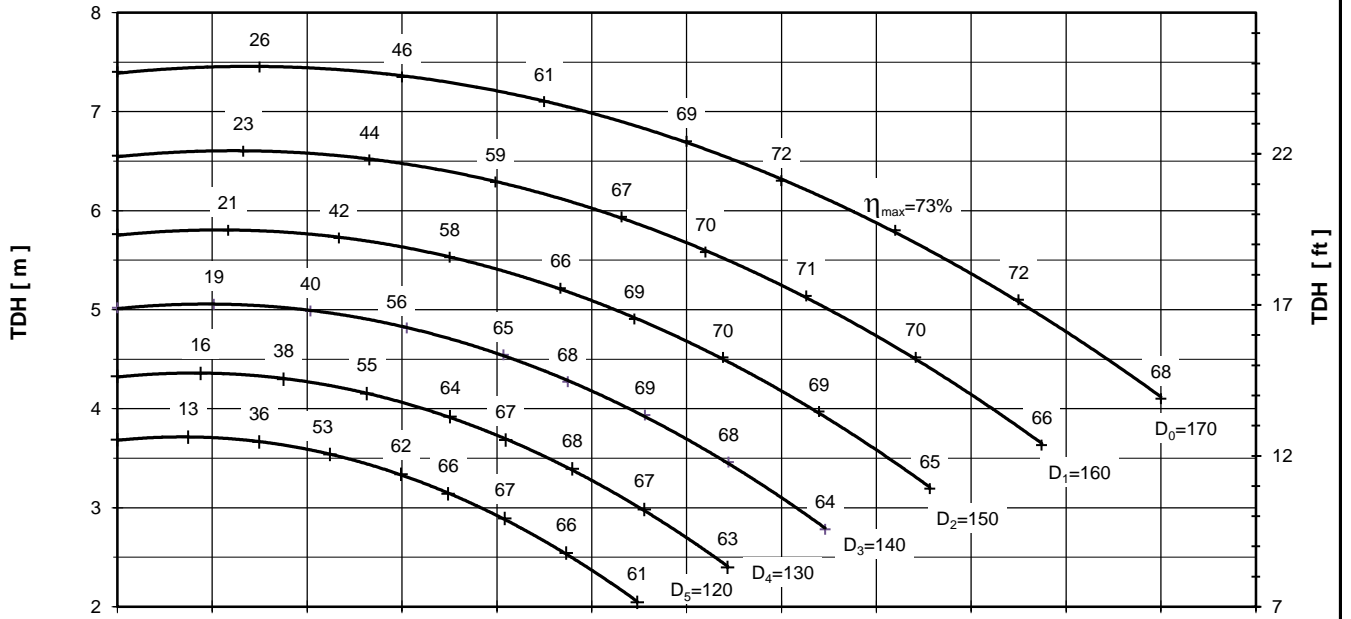

Performance curves are valid for clean cold water-kinematic viscosity 1 [mm<sup>2</sup>/s], density 1000 [kg/m<sup>3</sup>]. Methods and tolerances of presented performance curves are in accordance with ISO 9906 - Annex A



PUMP PERFORMANCE CURVES  
No. 4HD.0161.03

PUMP TYPE  
SCP 80 - 200  
1450 [rpm]

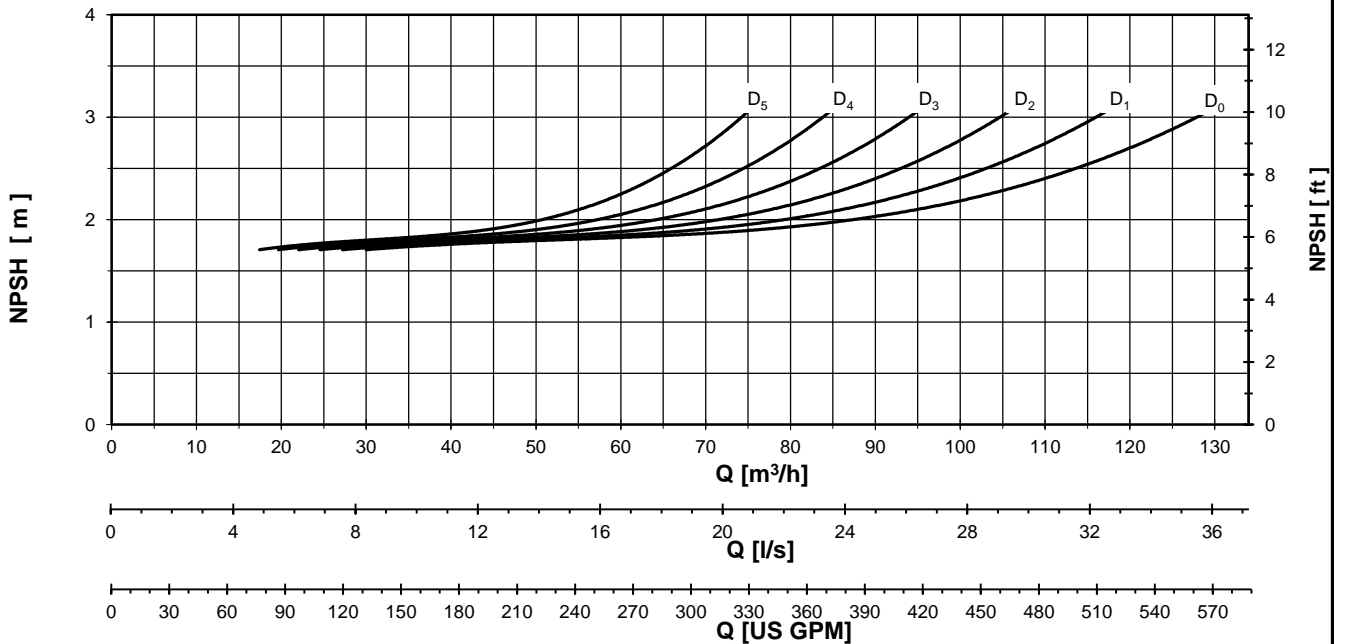
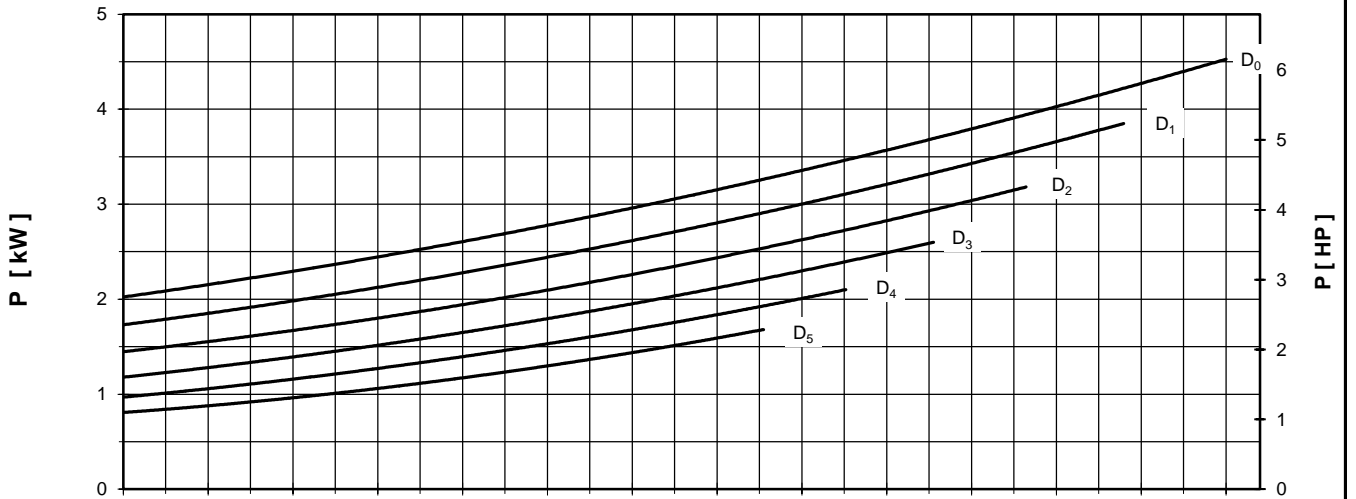
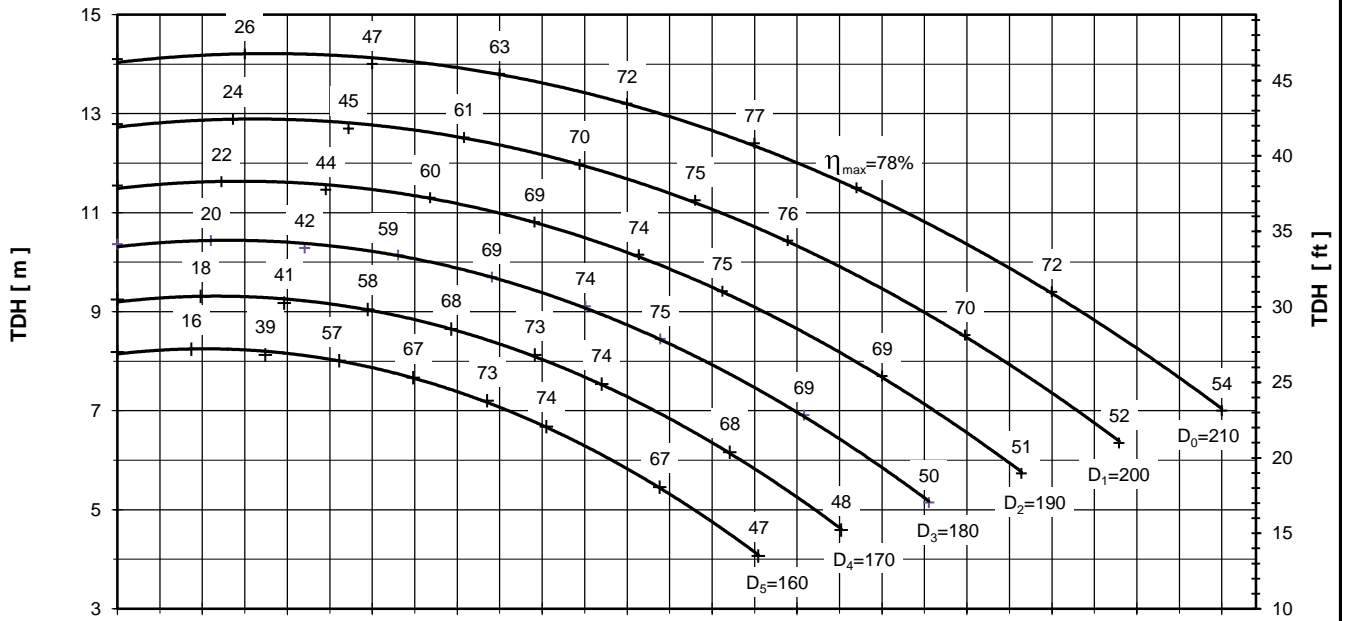

Performance curves are valid for clean cold water-kinematic viscosity 1 [mm²/s], density 1000 [kg/m³]. Methods and tolerances of presented performance curves are in accordance with ISO 9906 - Annex A



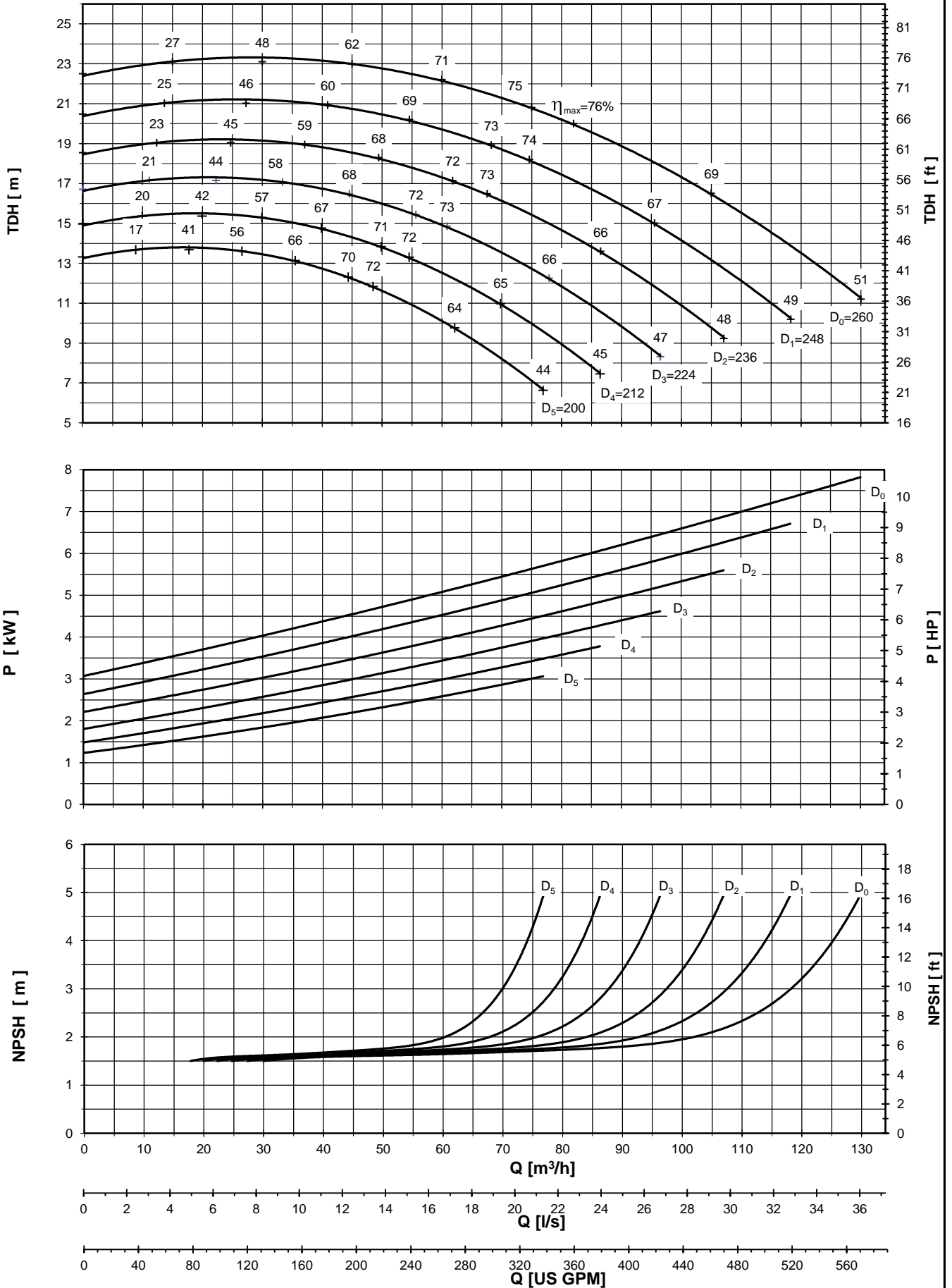

Performance curves are valid for clean cold water-kinematic viscosity 1 [mm<sup>2</sup>/s], density 1000 [kg/m<sup>3</sup>]. Methods and tolerances of presented performance curves are in accordance with ISO 9906 - Annex A



PUMP PERFORMANCE CURVES  
No. 4HD.0163.03

PUMP TYPE  
SCP 80 - 315  
1450 [rpm]

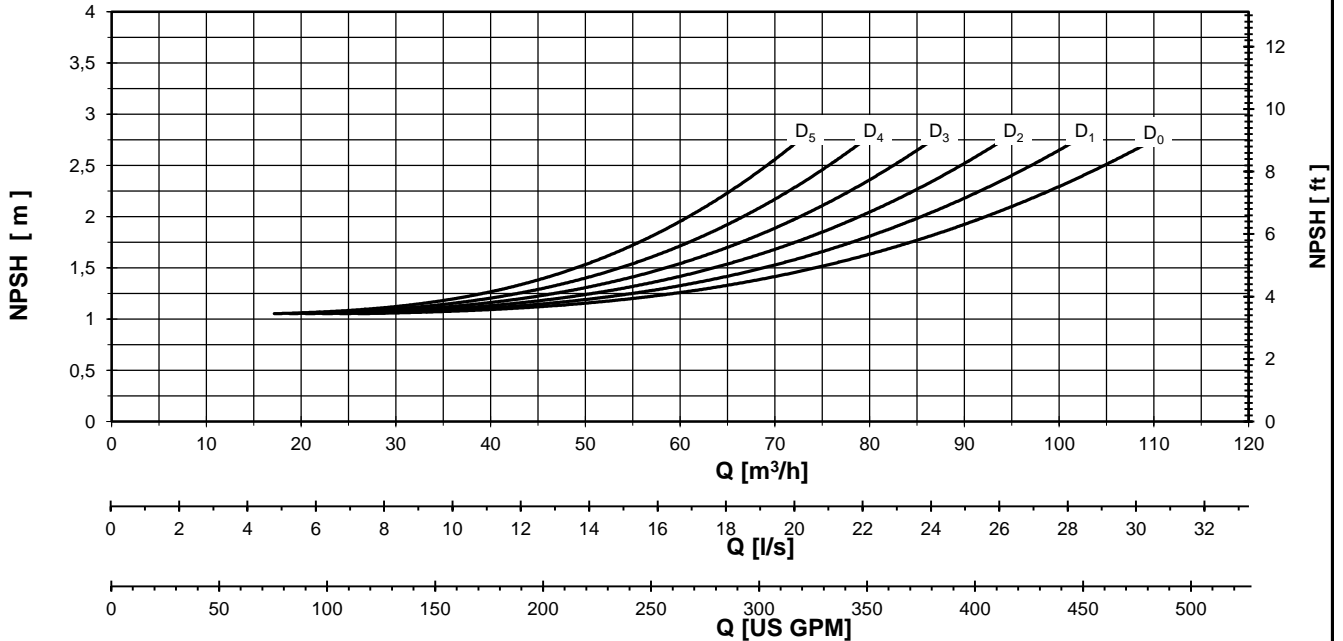
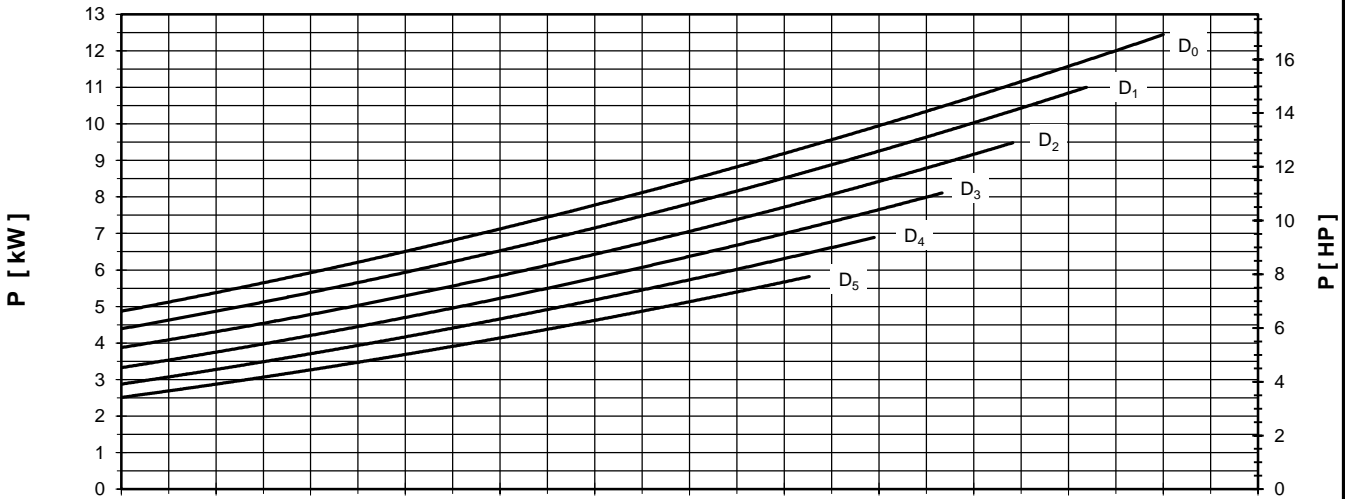
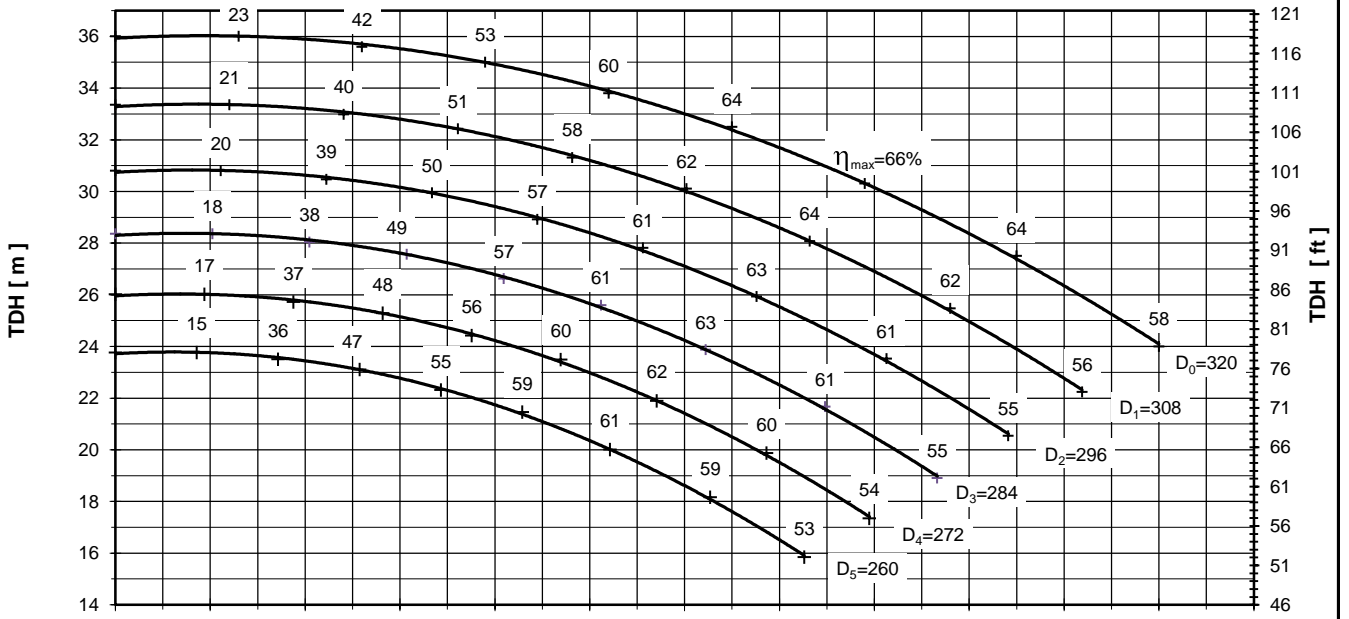

Performance curves are valid for clean cold water-kinematic viscosity 1 [mm<sup>2</sup>/s], density 1000 [kg/m<sup>3</sup>]. Methods and tolerances of presented performance curves are in accordance with ISO 9906 - Annex A



PUMP PERFORMANCE CURVES  
No. 4HD.0164.03

PUMP TYPE  
SCP 80 - 400  
1450 [rpm]

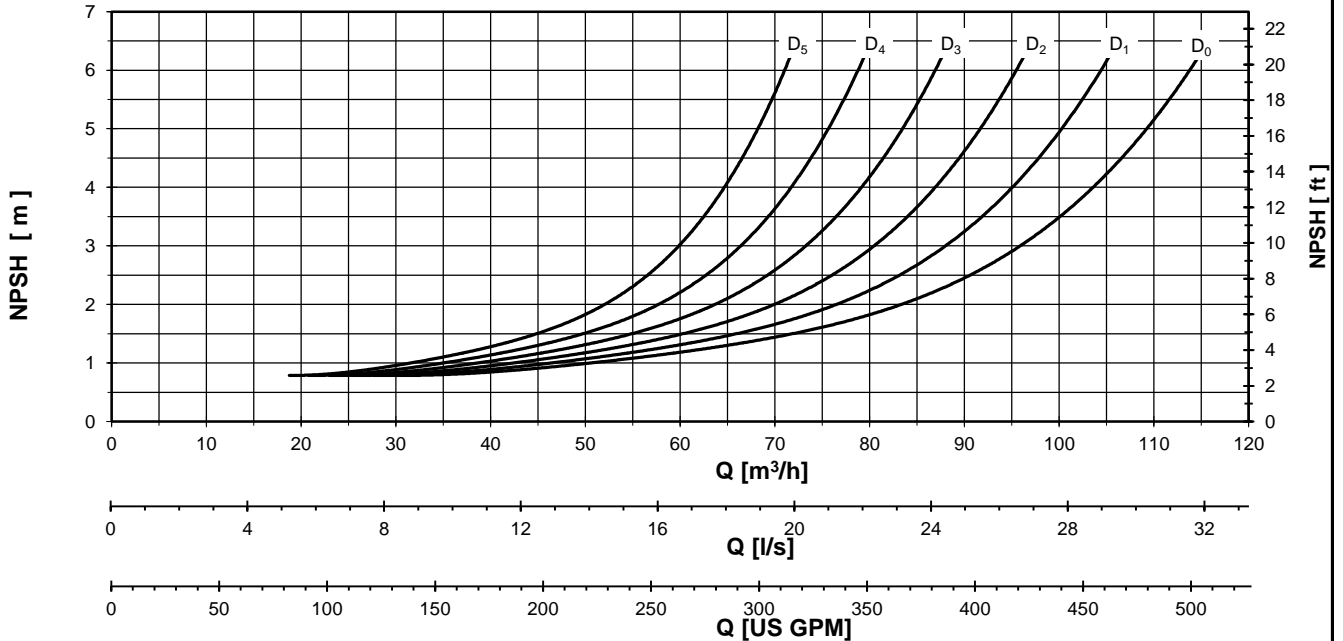
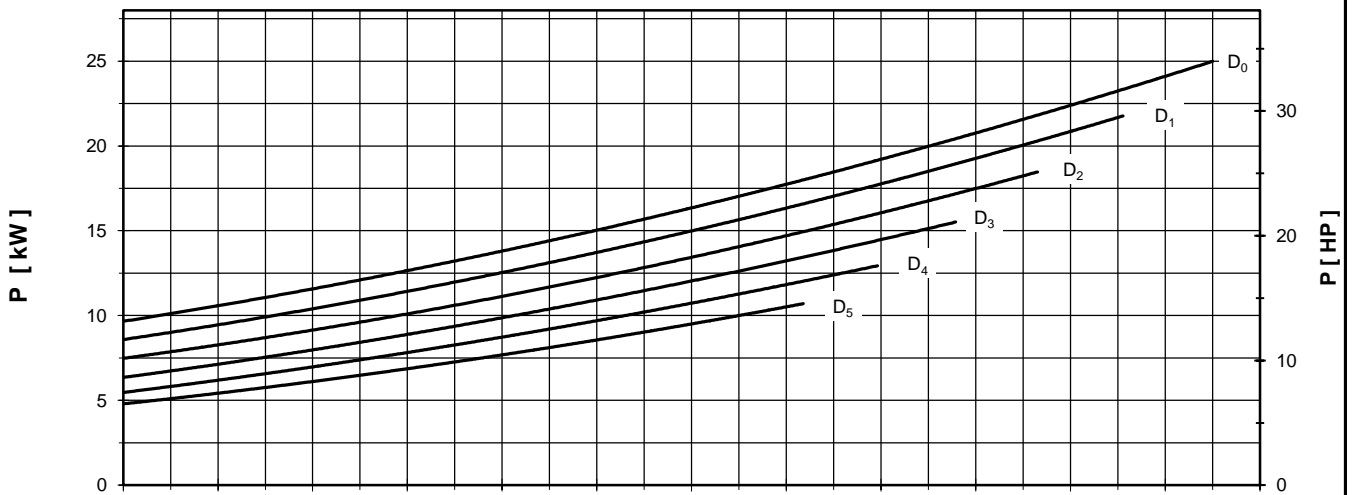
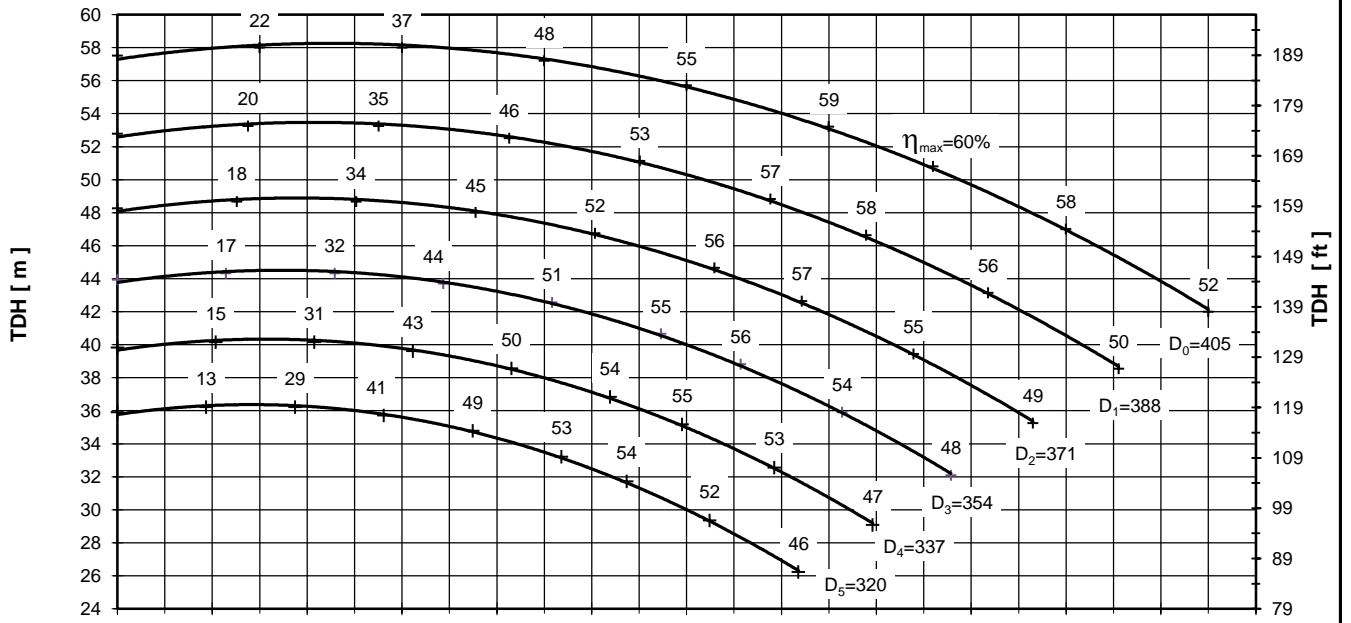

Performance curves are valid for clean cold water-kinematic viscosity 1 [mm²/s], density 1000 [kg/m³]. Methods and tolerances of presented performance curves are in accordance with ISO 9906 - Annex A

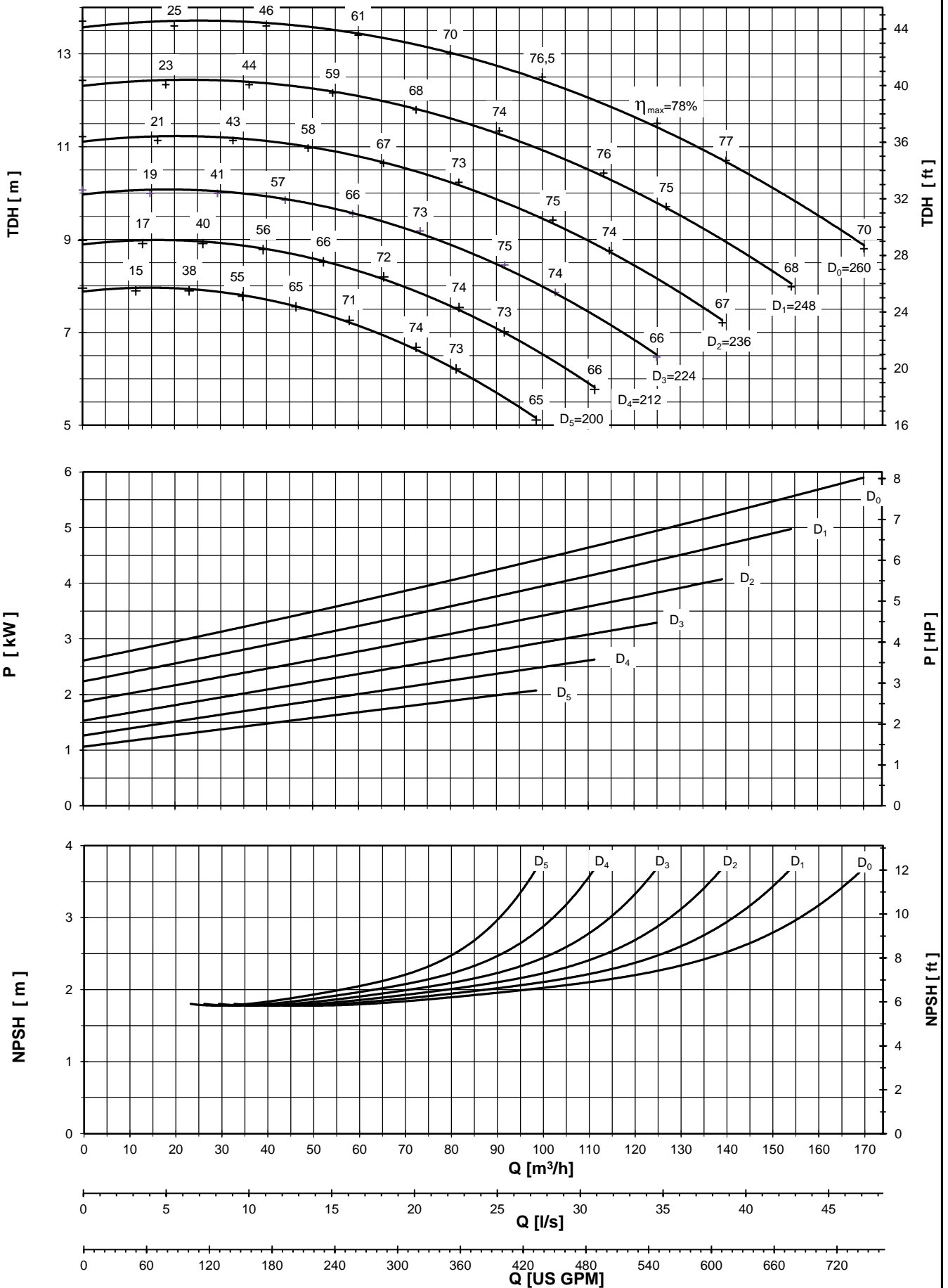

Performance curves are valid for clean cold water-kinematic viscosity 1 [mm<sup>2</sup>/s], density 1000 [kg/m<sup>3</sup>]. Methods and tolerances of presented performance curves are in accordance with ISO 9906 - Annex A

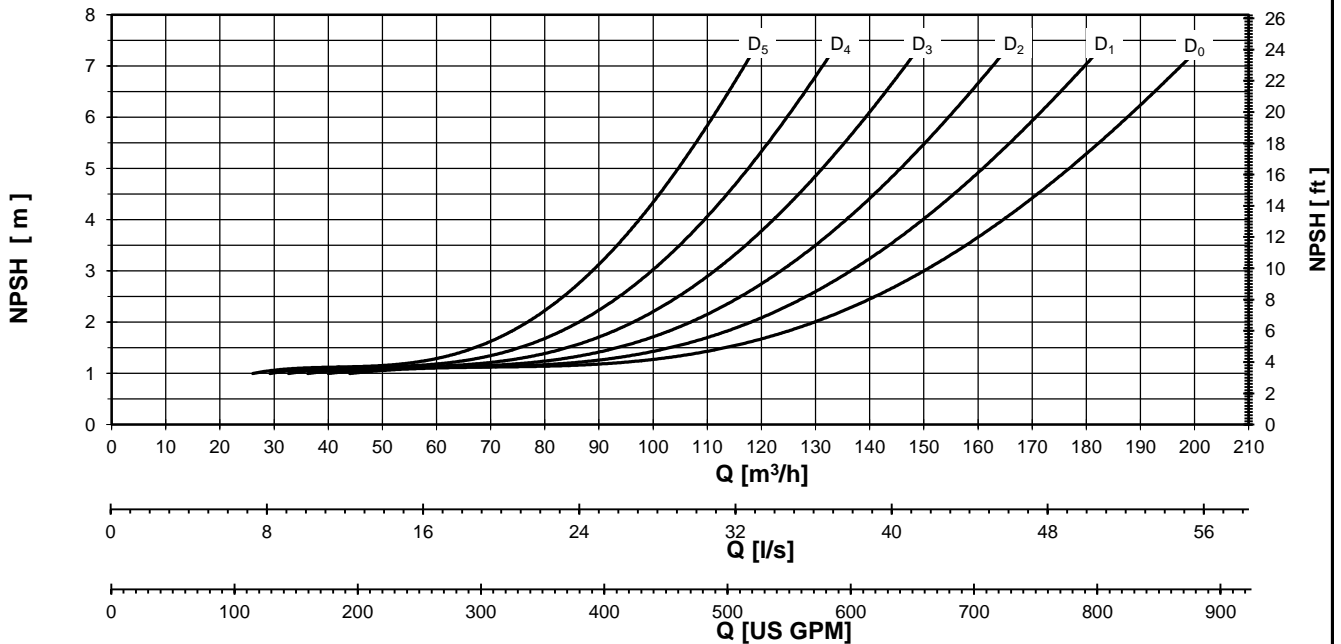
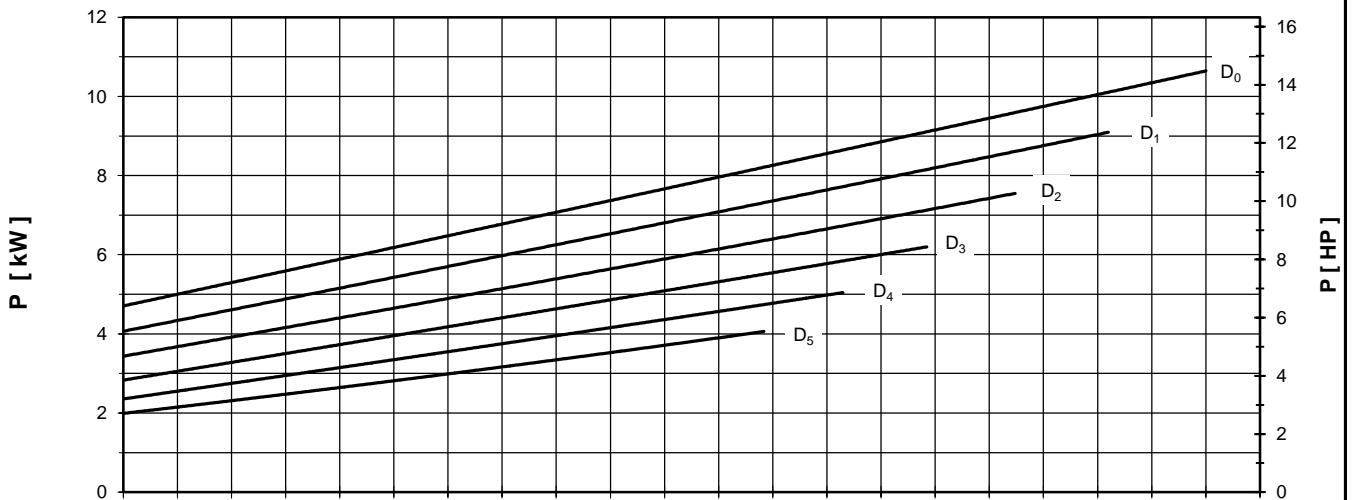
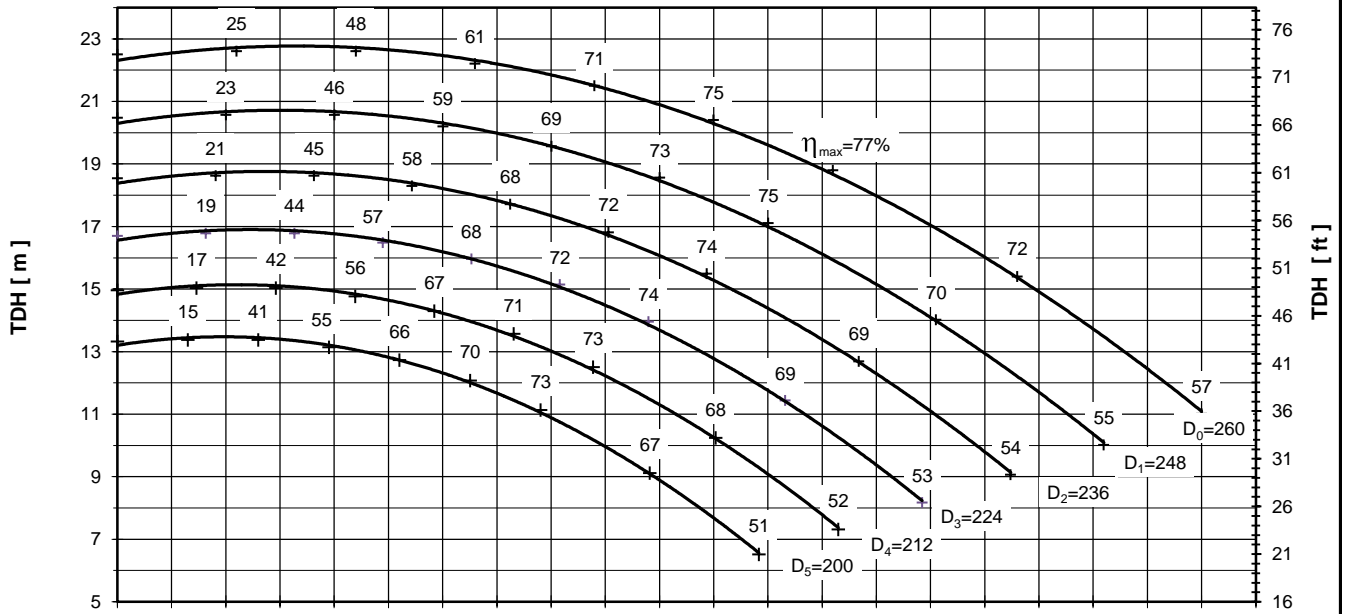

Performance curves are valid for clean cold water-kinematic viscosity 1 [mm<sup>2</sup>/s], density 1000 [kg/m<sup>3</sup>]. Methods and tolerances of presented performance curves are in accordance with ISO 9906 - Annex A



PUMP PERFORMANCE CURVES  
No. 4HD.0167.03

PUMP TYPE  
SCP 100 - 315  
1450 [rpm]

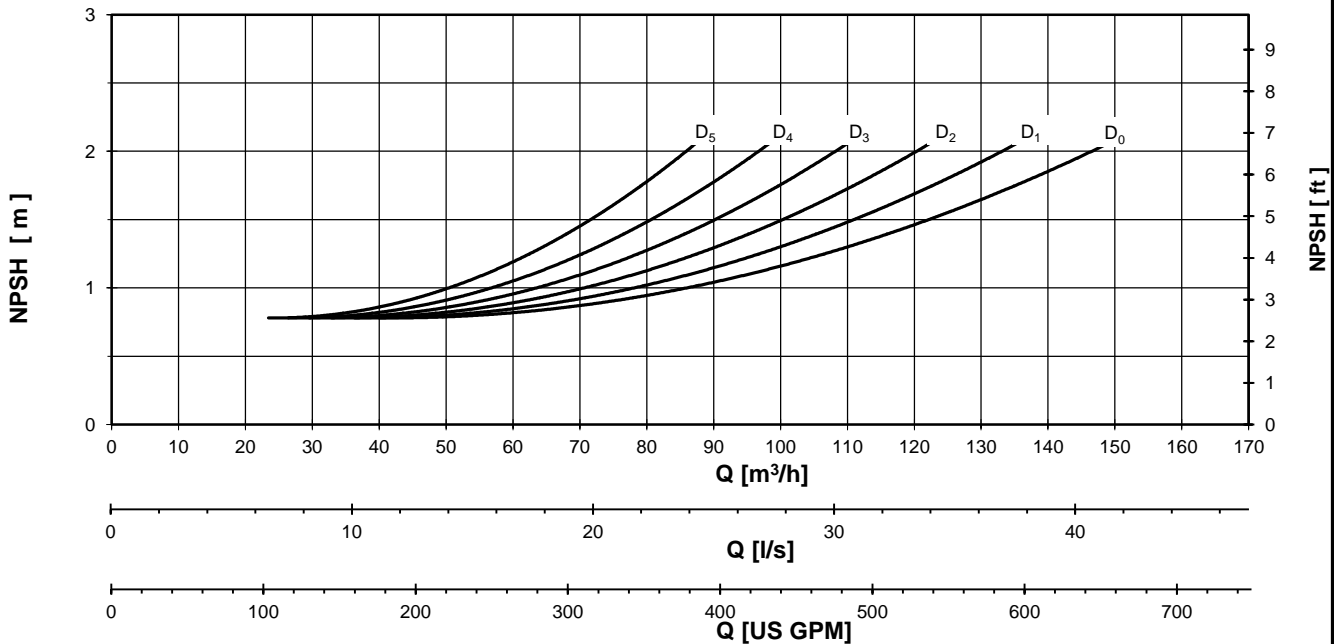
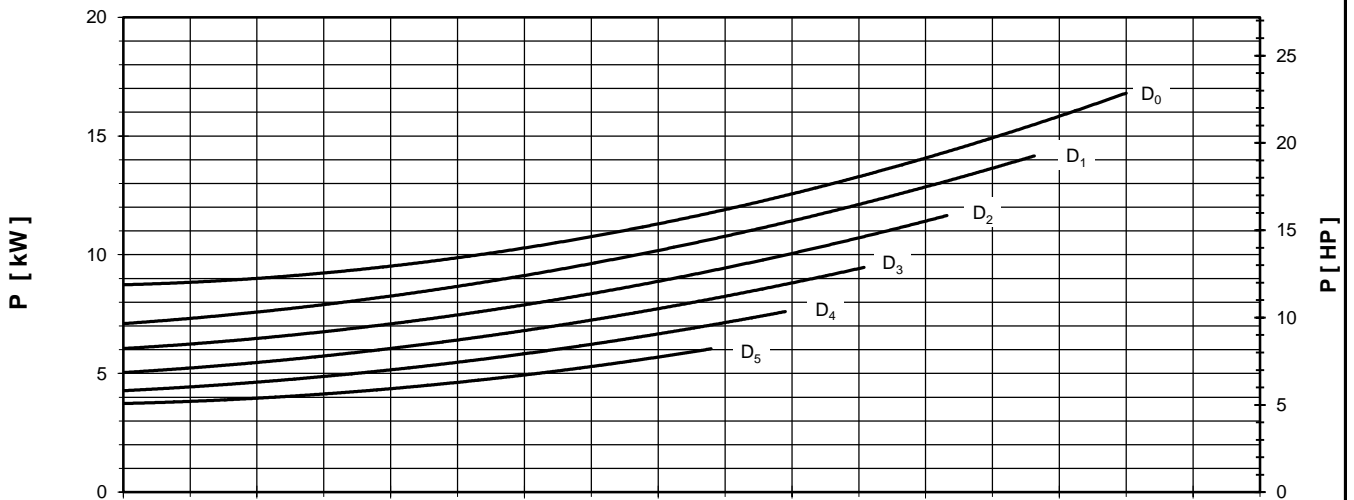
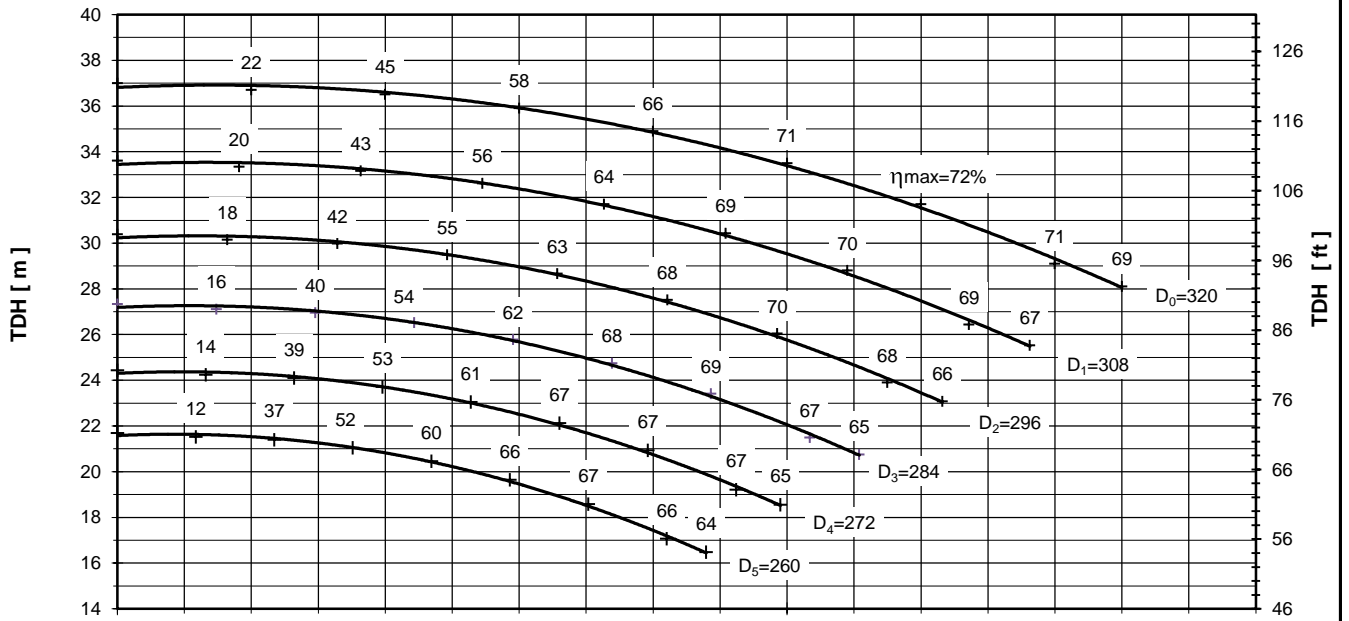

Performance curves are valid for clean cold water-kinematic viscosity 1 [mm²/s], density 1000 [kg/m³]. Methods and tolerances of presented performance curves are in accordance with ISO 9906 - Annex A

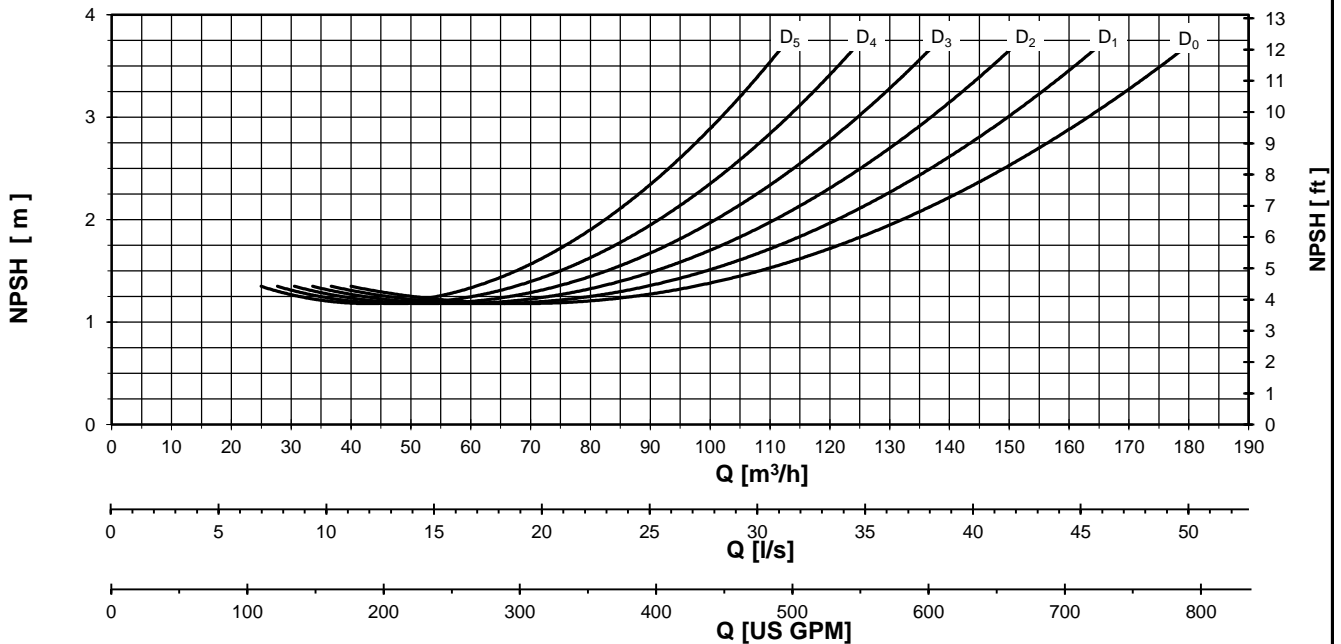
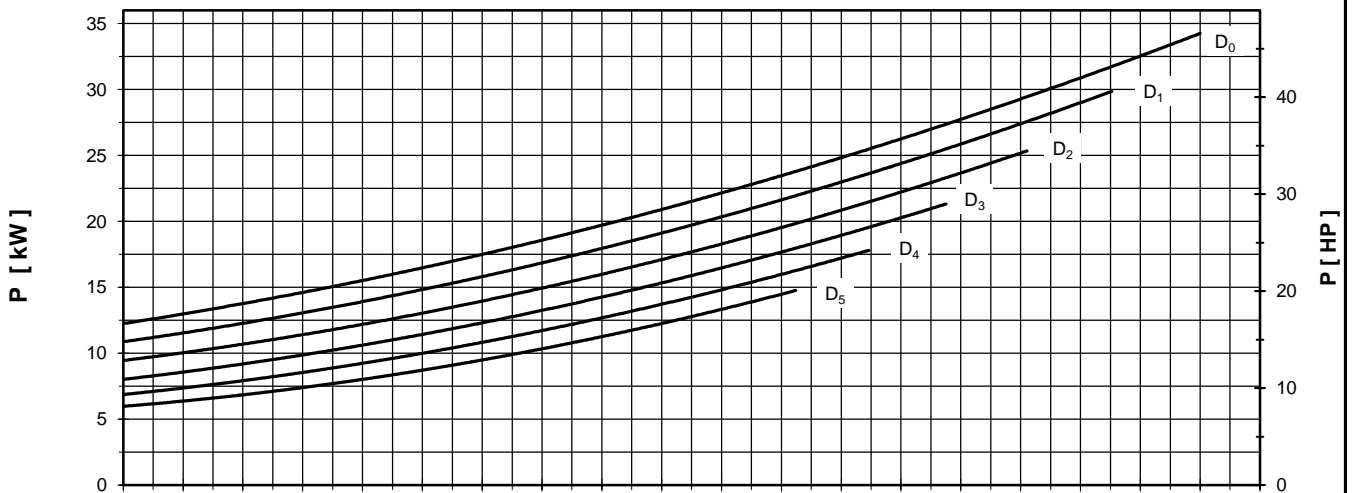
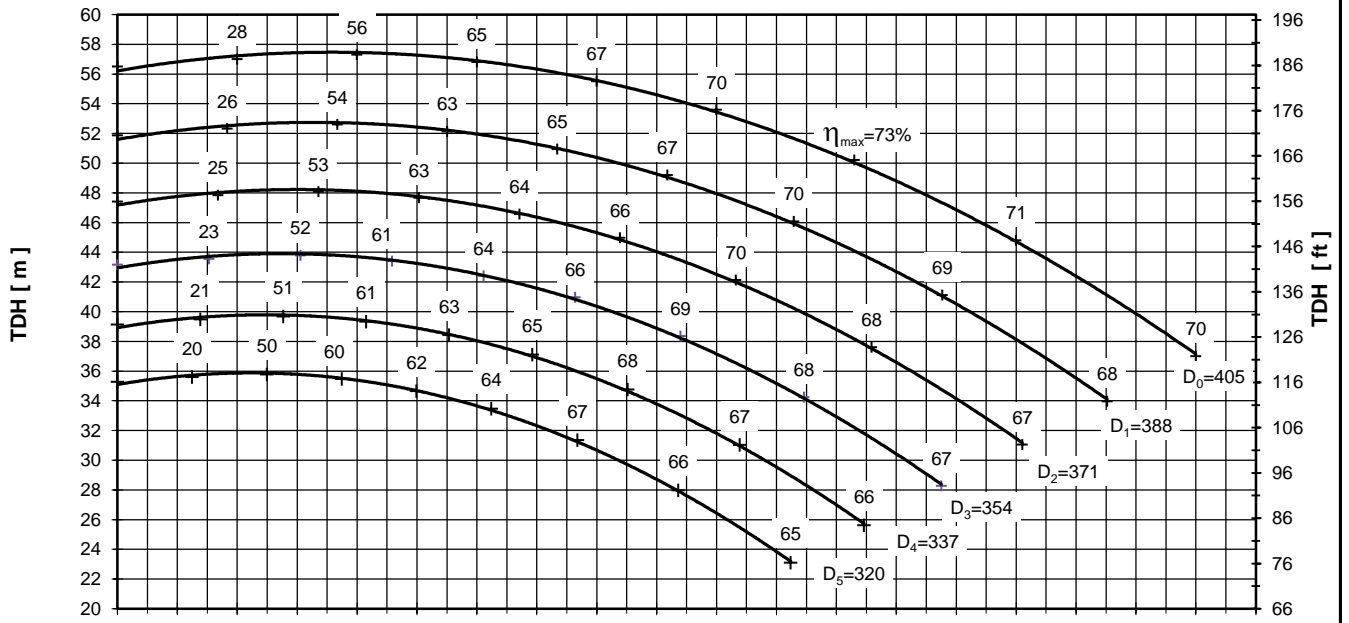

Performance curves are valid for clean cold water-kinematic viscosity 1 [mm²/s], density 1000 [kg/m³]. Methods and tolerances of presented performance curves are in accordance with ISO 9906 - Annex A



PUMP PERFORMANCE CURVES  
No. 4HD.0169.03

PUMP TYPE
SCP 125 - 250
1450 [rpm]

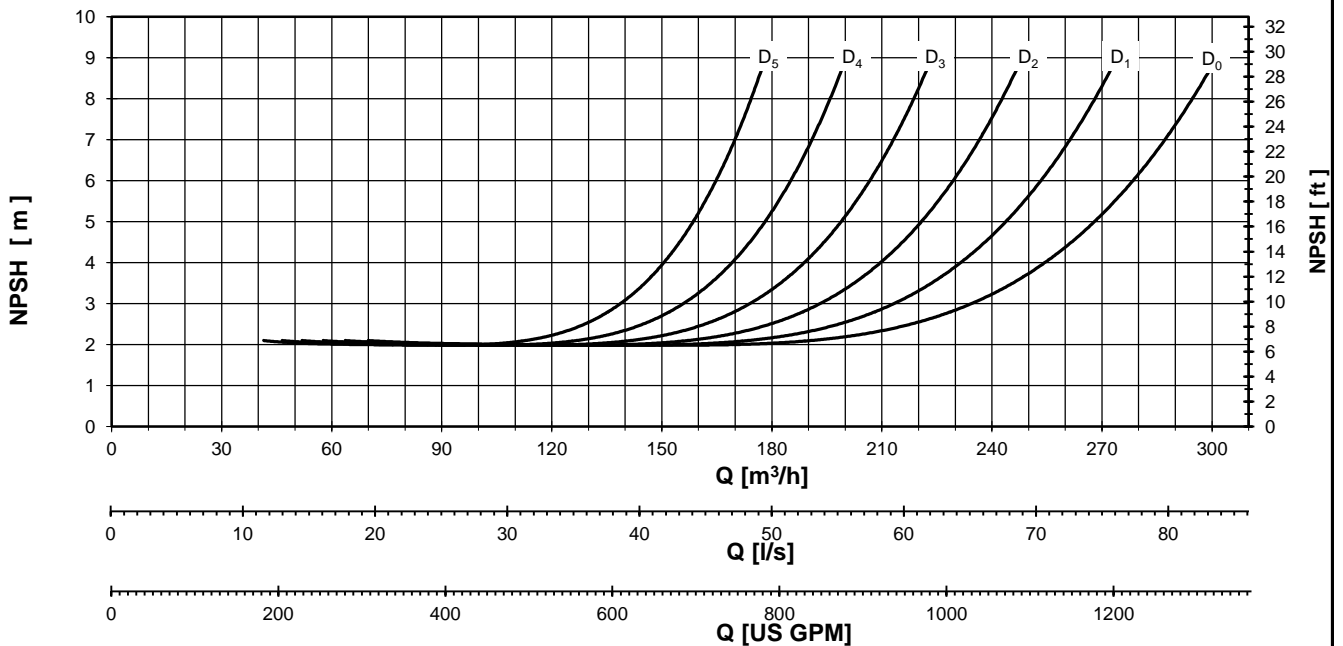
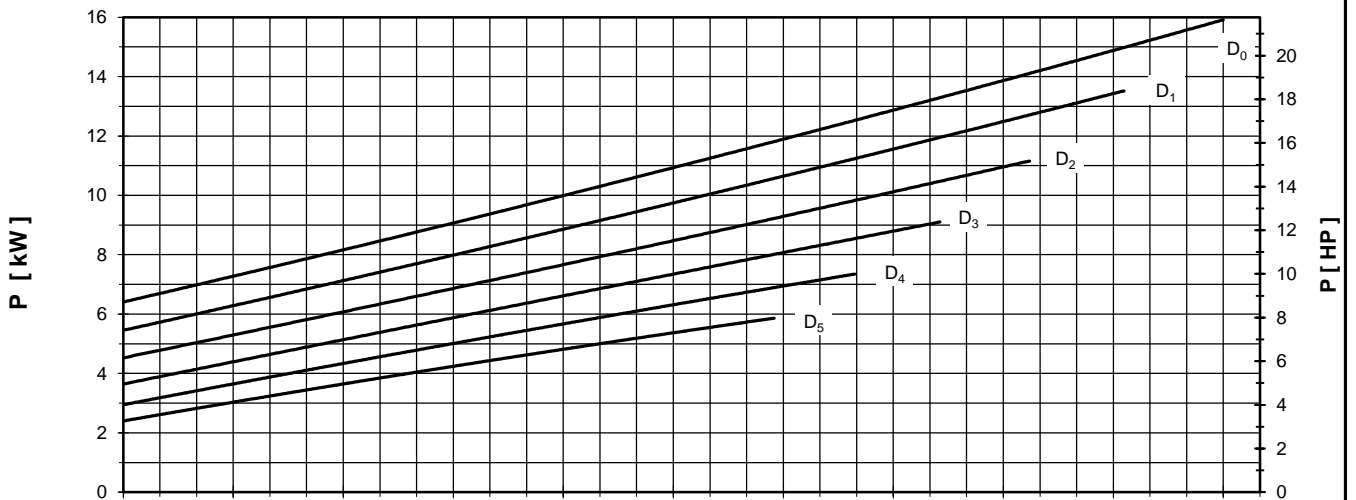
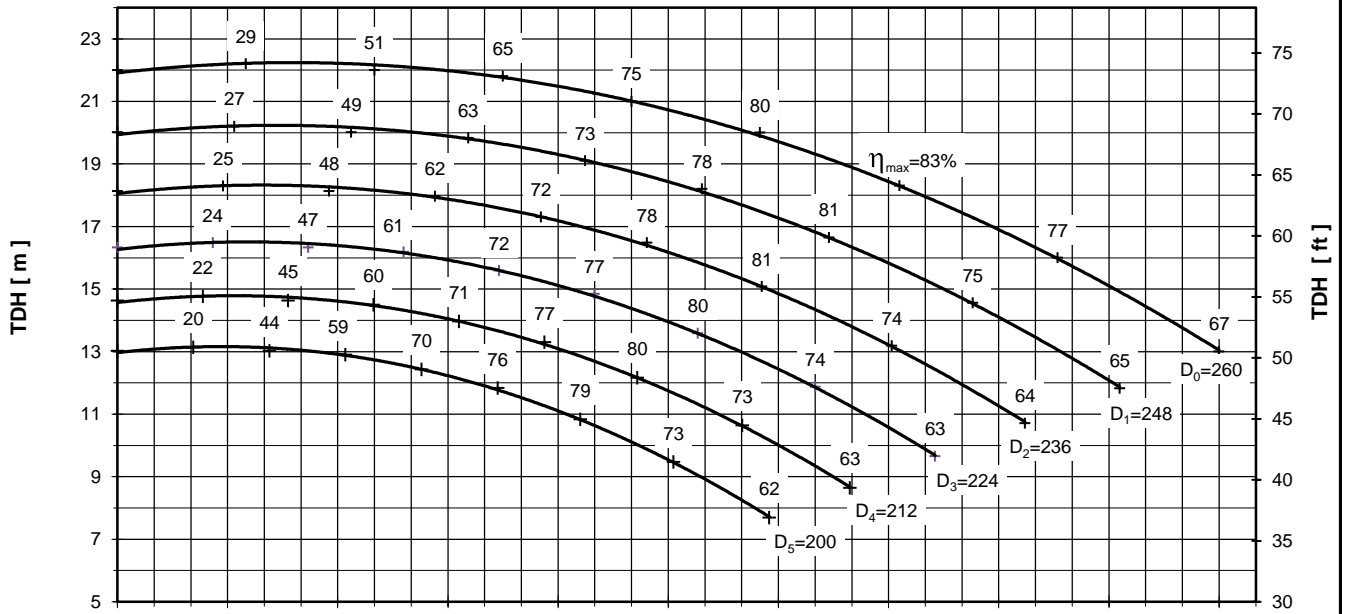

Performance curves are valid for clean cold water-kinematic viscosity 1 [mm<sup>2</sup>/s], density 1000 [kg/m<sup>3</sup>]. Methods and tolerances of presented performance curves are in accordance with ISO 9906 - Annex A



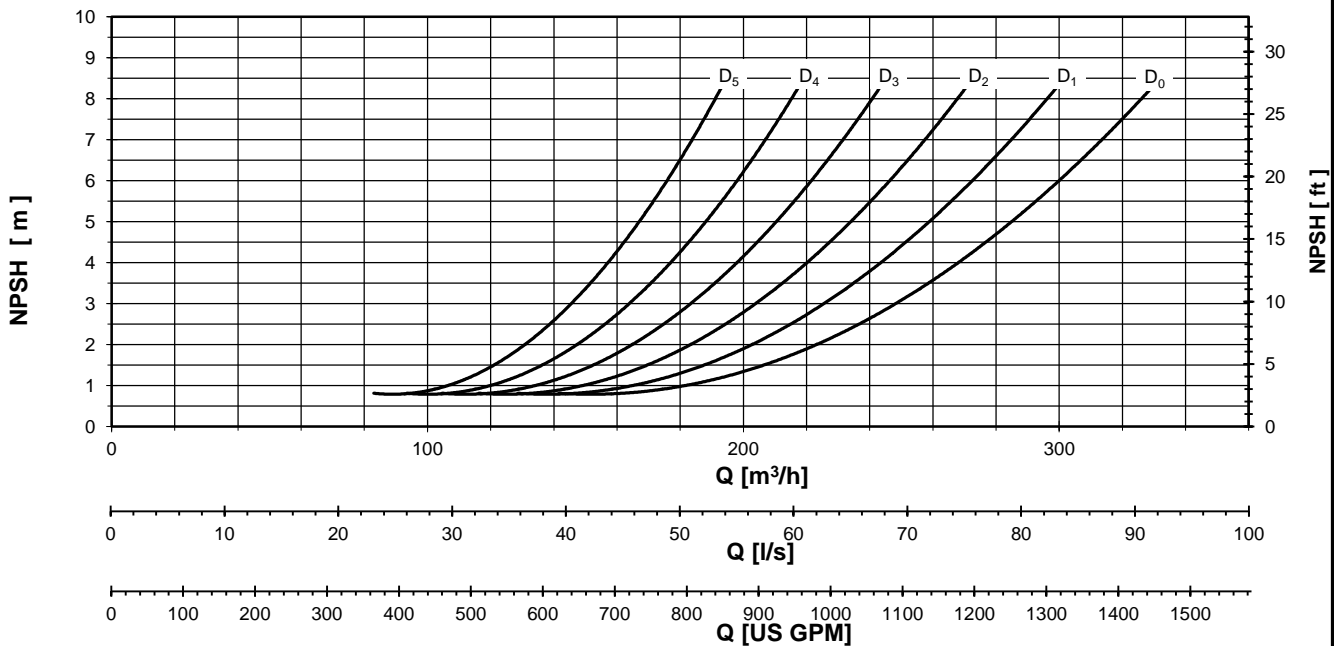
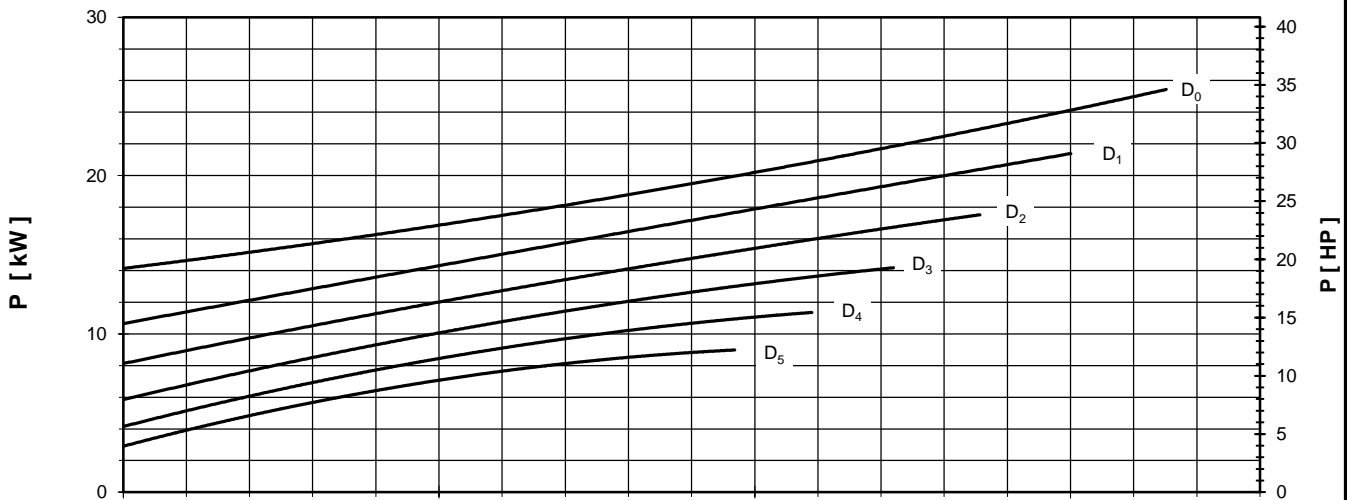
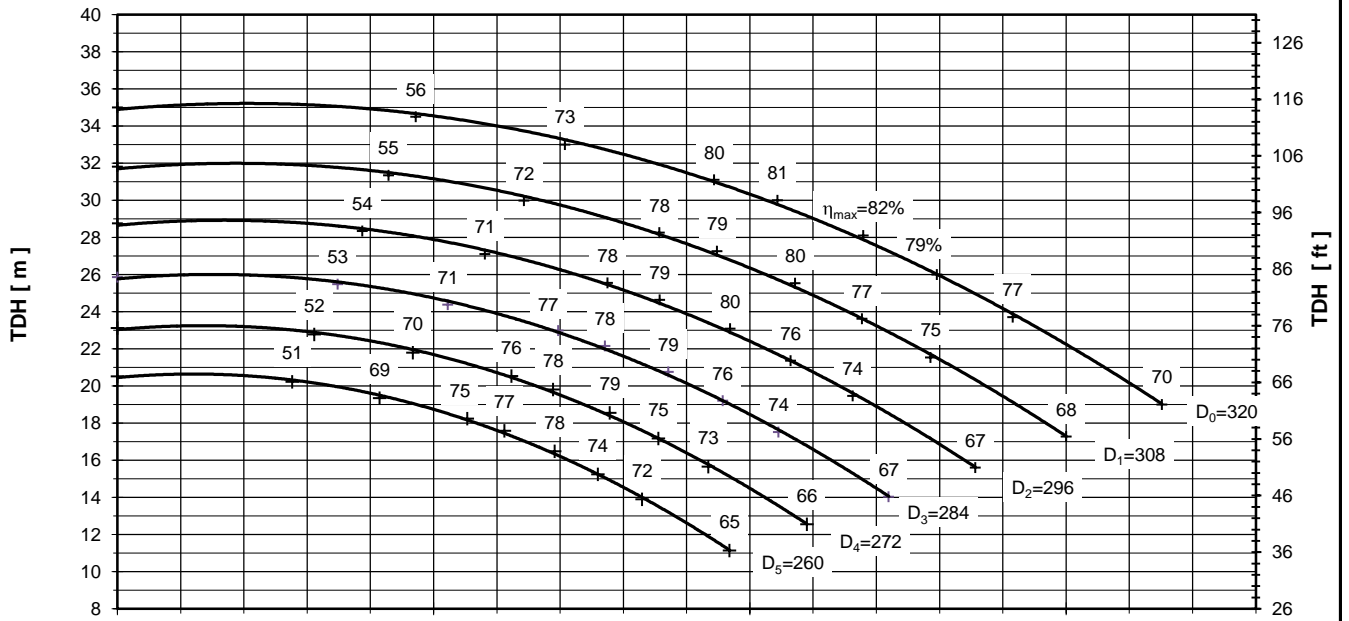

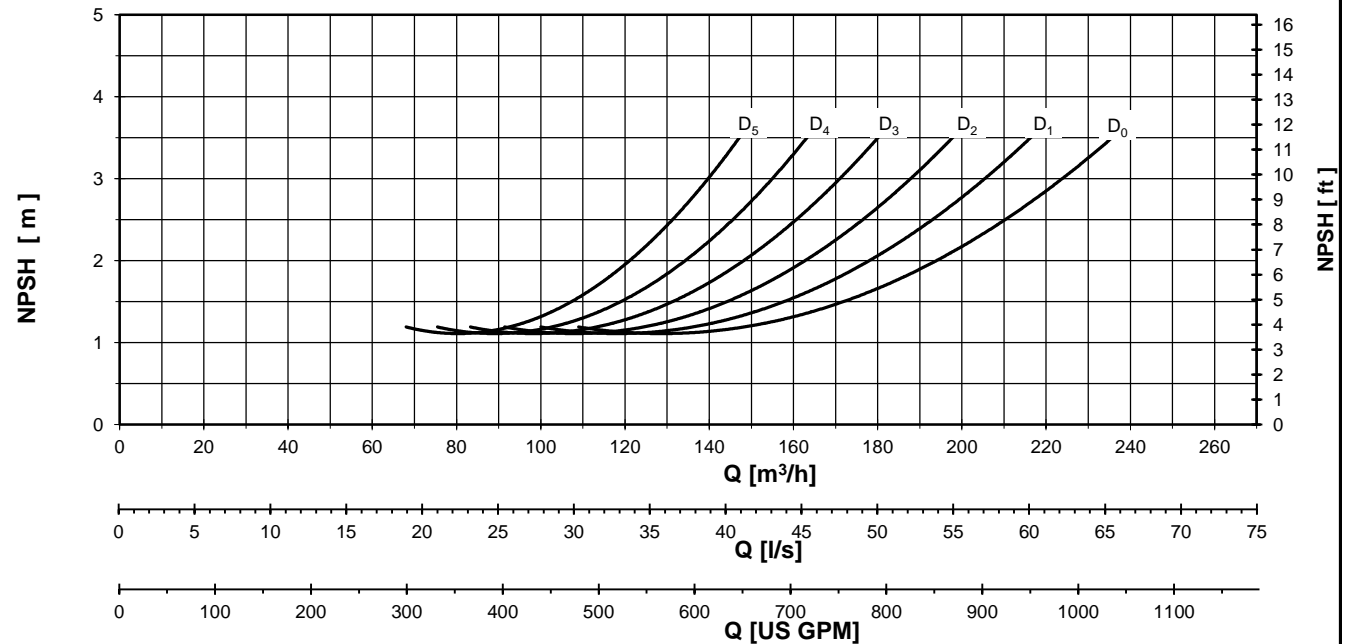
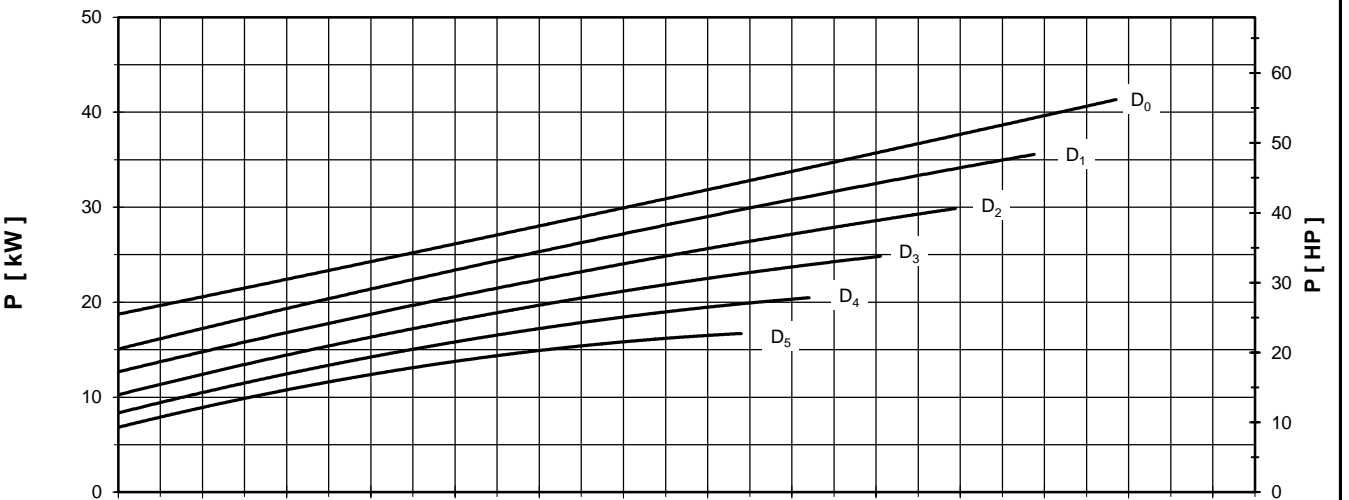
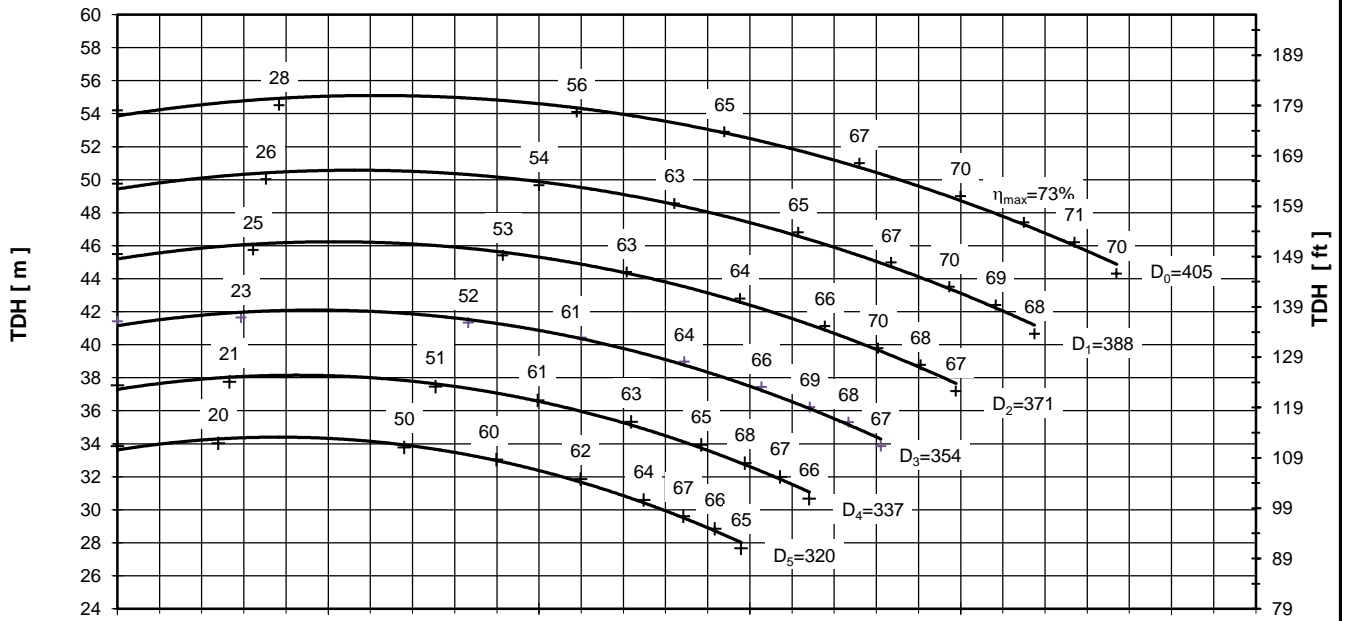

Performance curves are valid for clean cold water-kinematic viscosity 1 [mm<sup>2</sup>/s], density 1000 [kg/m<sup>3</sup>]. Methods and tolerances of presented performance curves are in accordance with ISO 9906 - Annex A



PUMP PERFORMANCE CURVES  
No. 4HD.0172.03

PUMP TYPE  
SCP 150 - 250  
1450 [rpm]

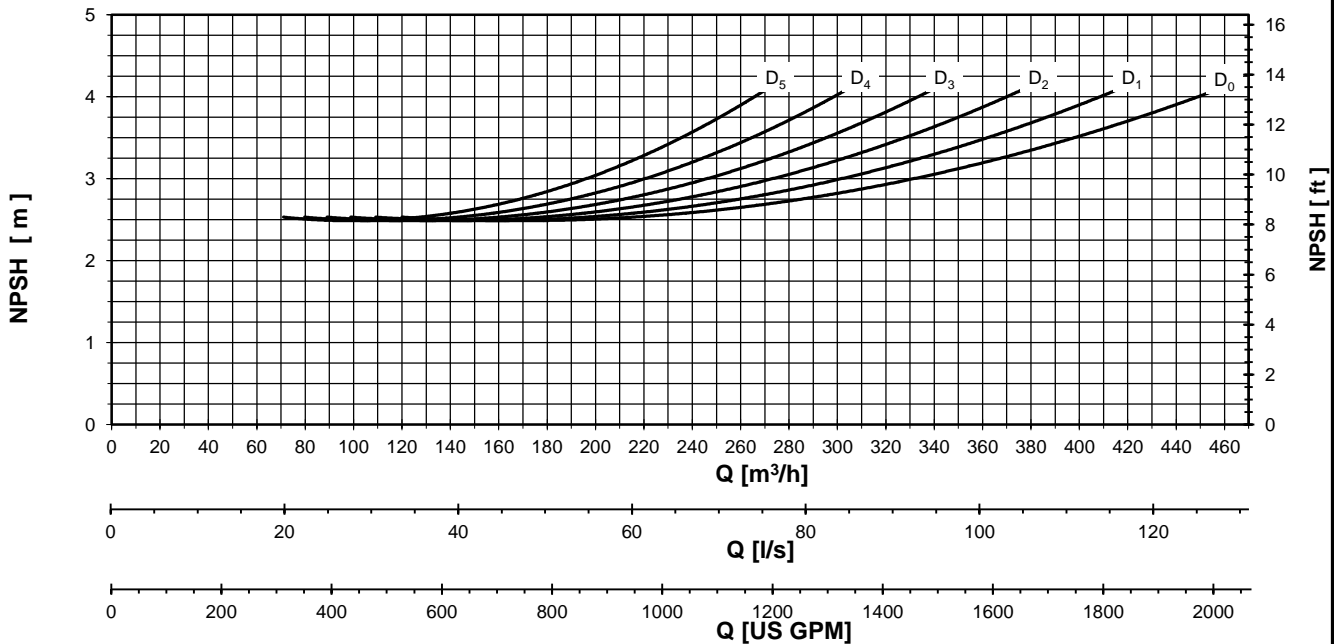
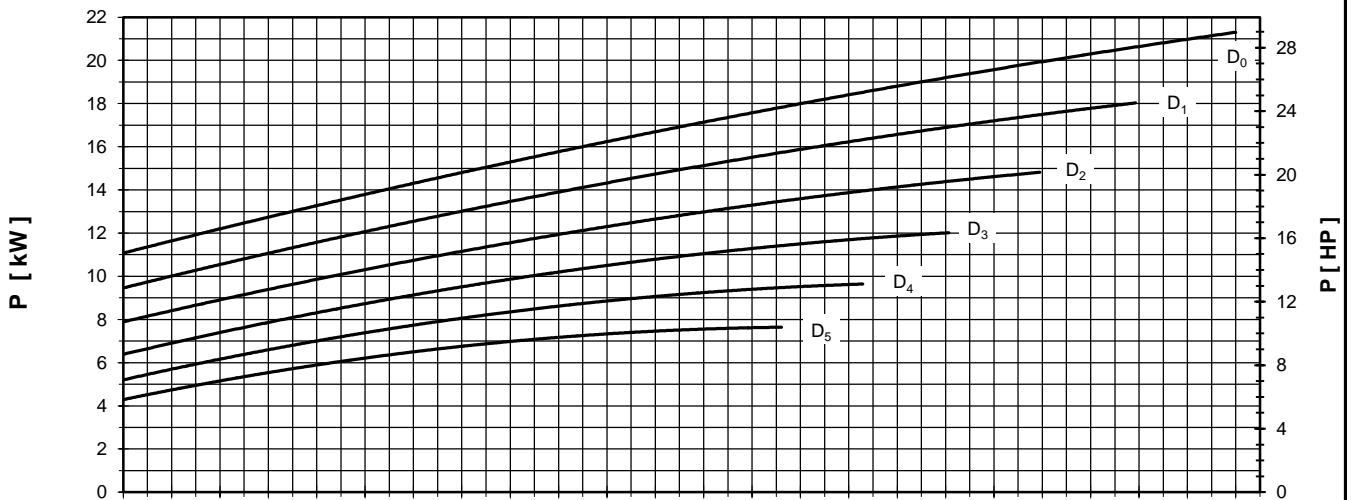
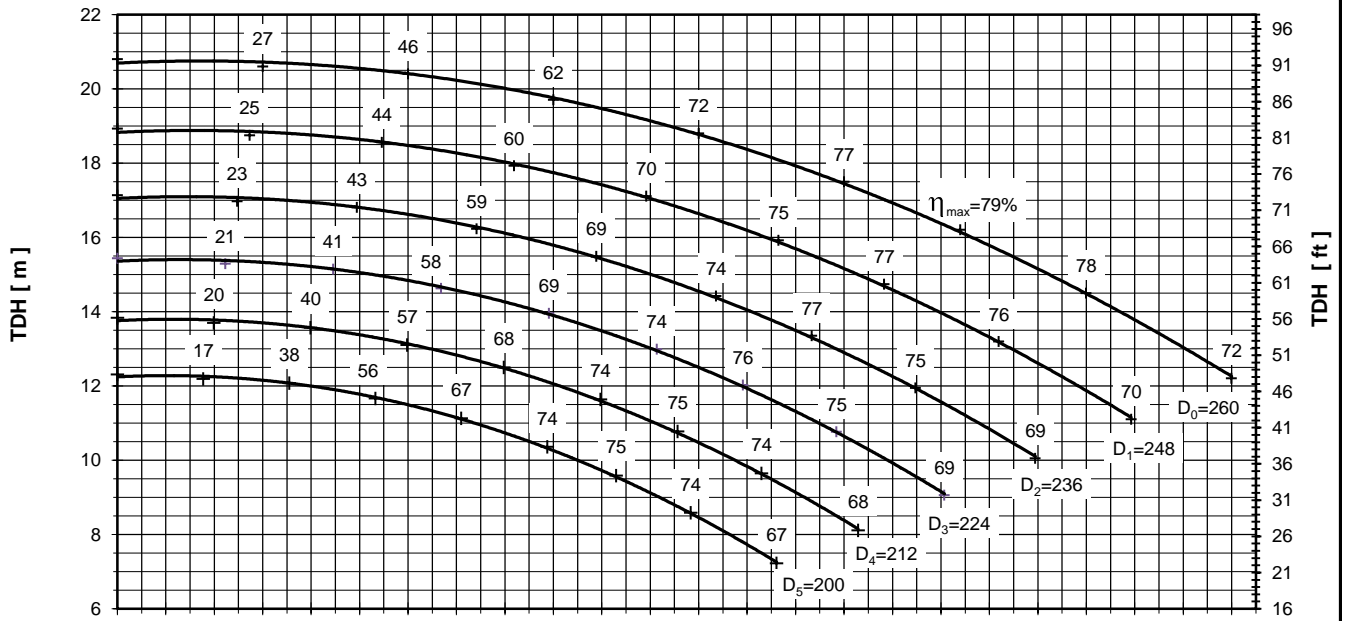

Performance curves are valid for clean cold water-kinematic viscosity 1 [mm²/s], density 1000 [kg/m³]. Methods and tolerances of presented performance curves are in accordance with ISO 9906 - Annex A

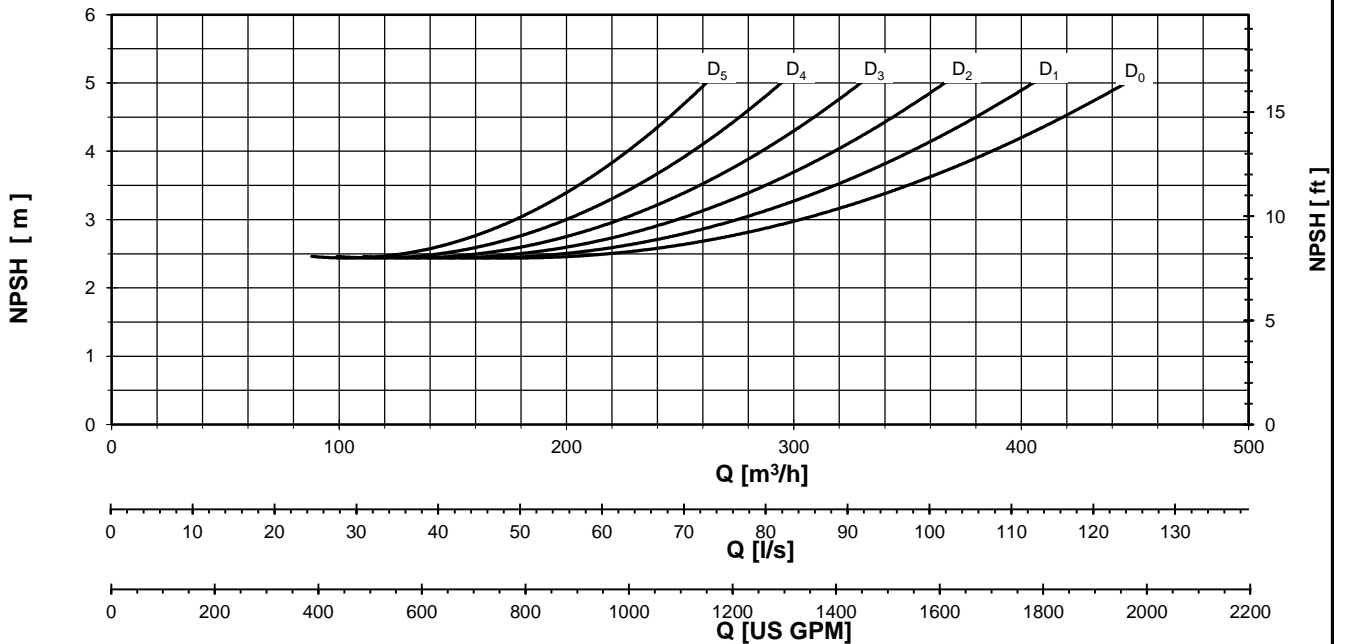
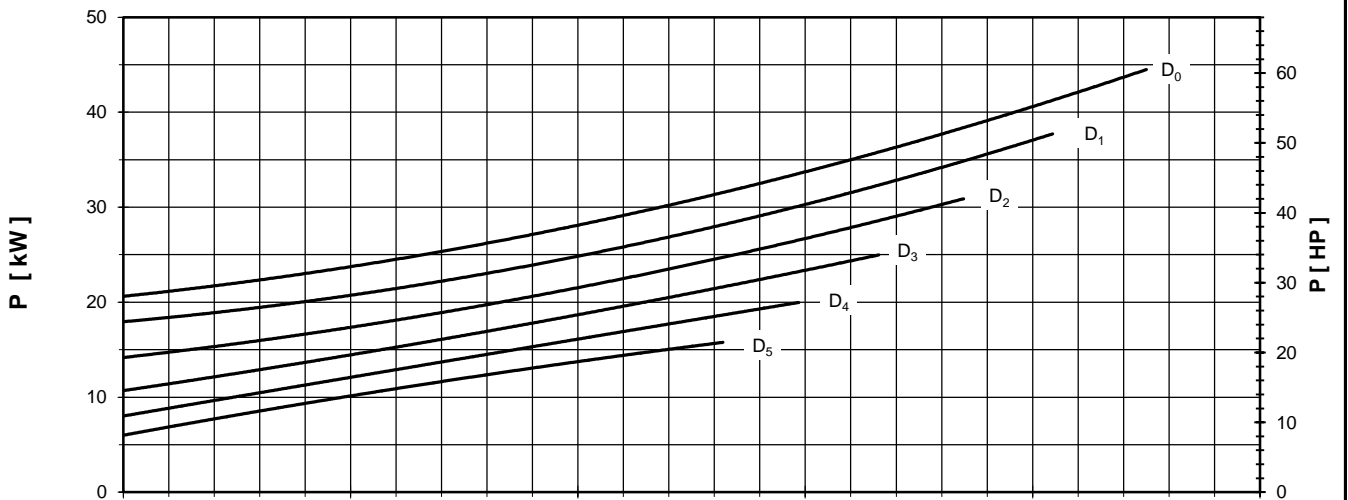
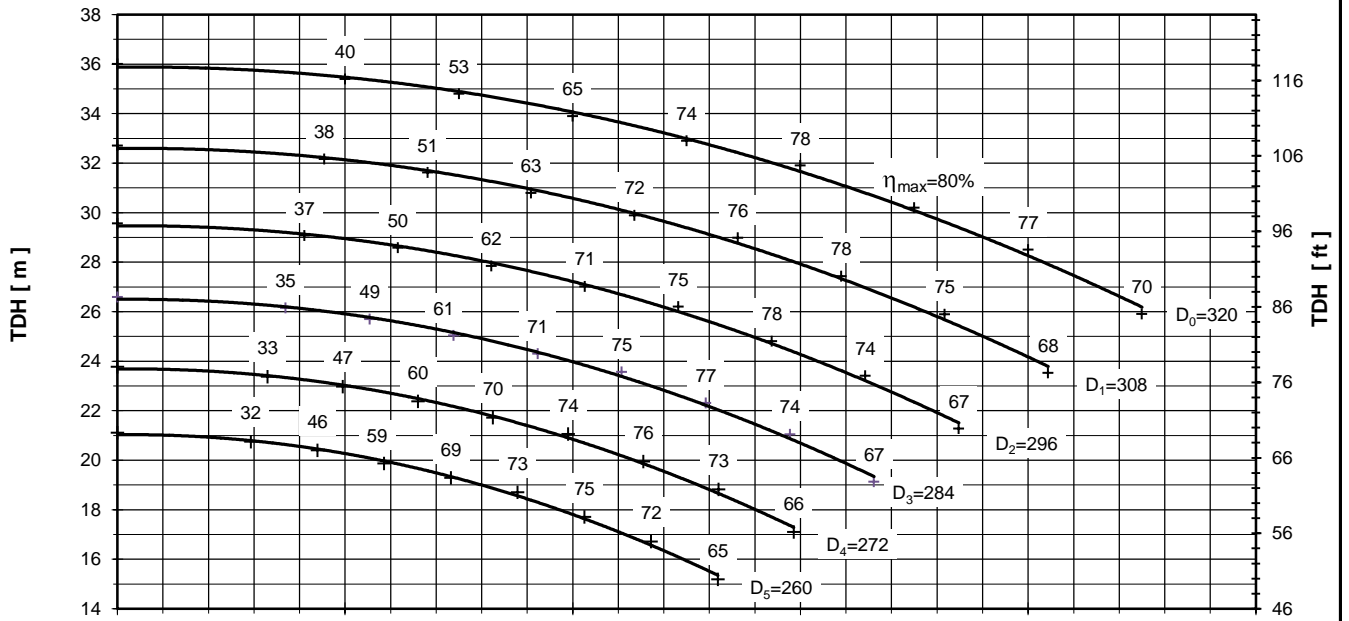

Performance curves are valid for clean cold water-kinematic viscosity 1 [mm²/s], density 1000 [kg/m³]. Methods and tolerances of presented performance curves are in accordance with ISO 9906 - Annex A

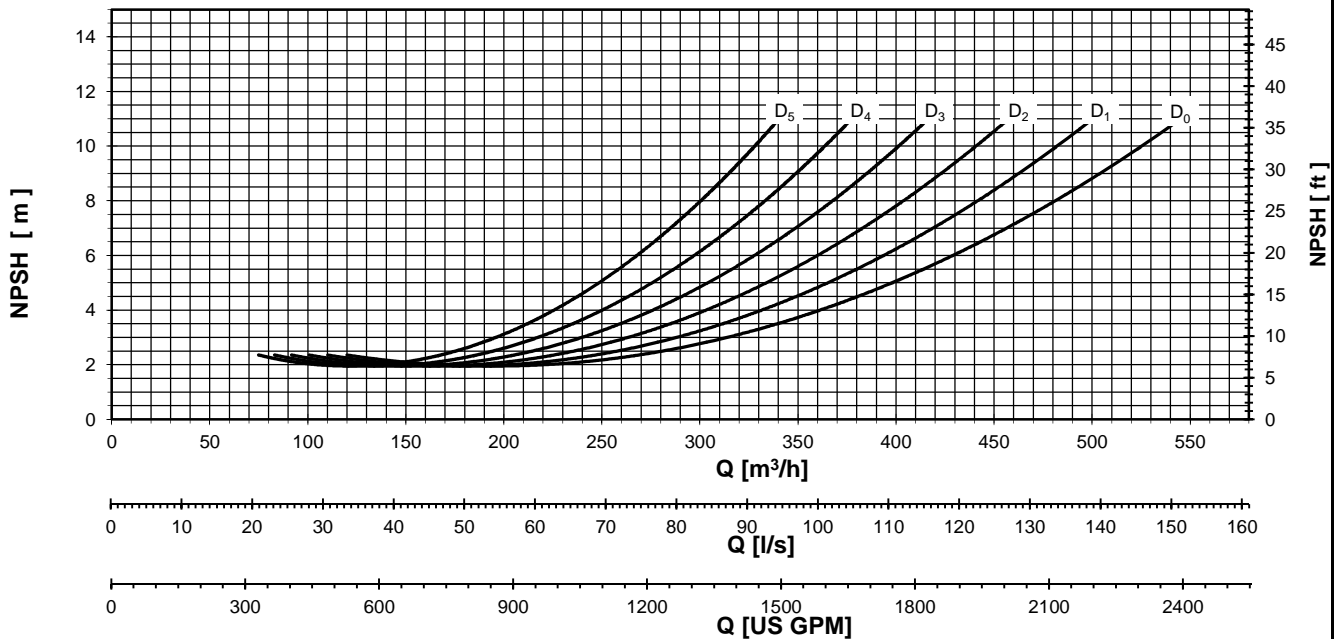
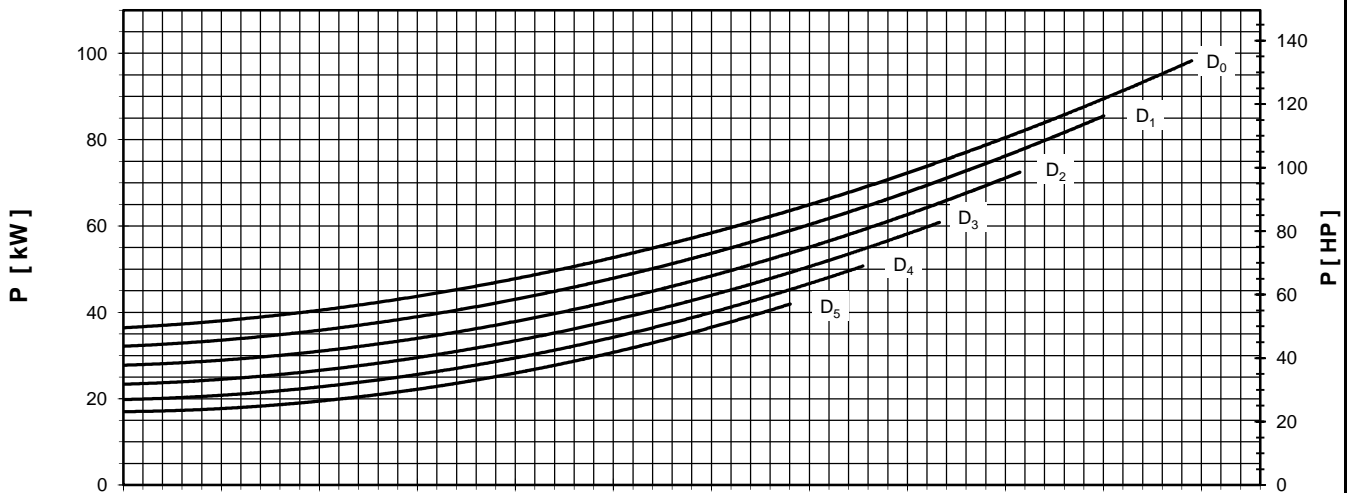
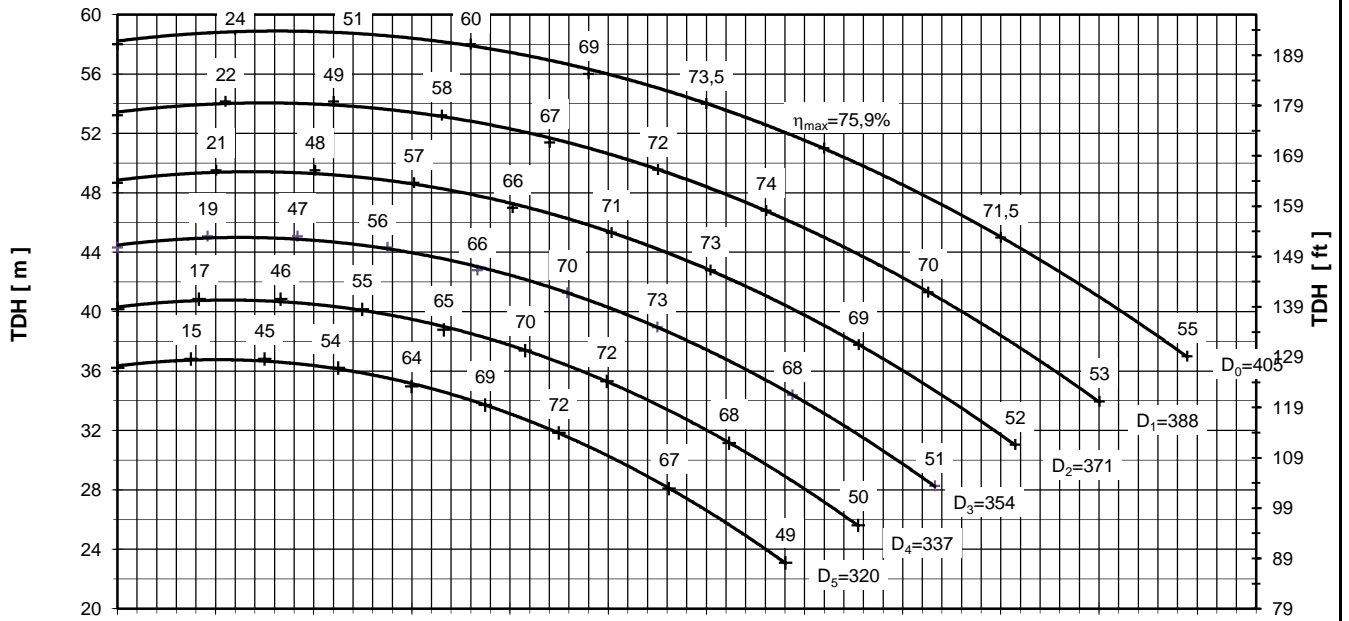

Performance curves are valid for clean cold water-kinematic viscosity 1 [mm²/s], density 1000 [kg/m³]. Methods and tolerances of presented performance curves are in accordance with ISO 9906 - Annex A

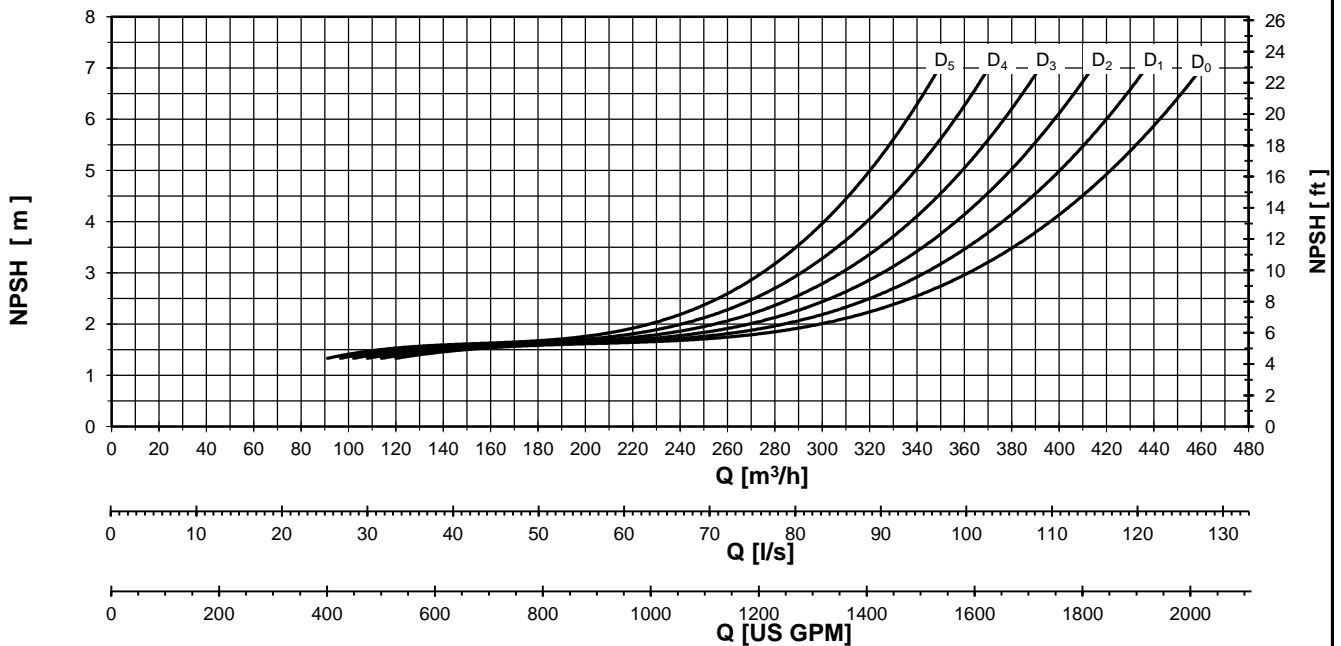
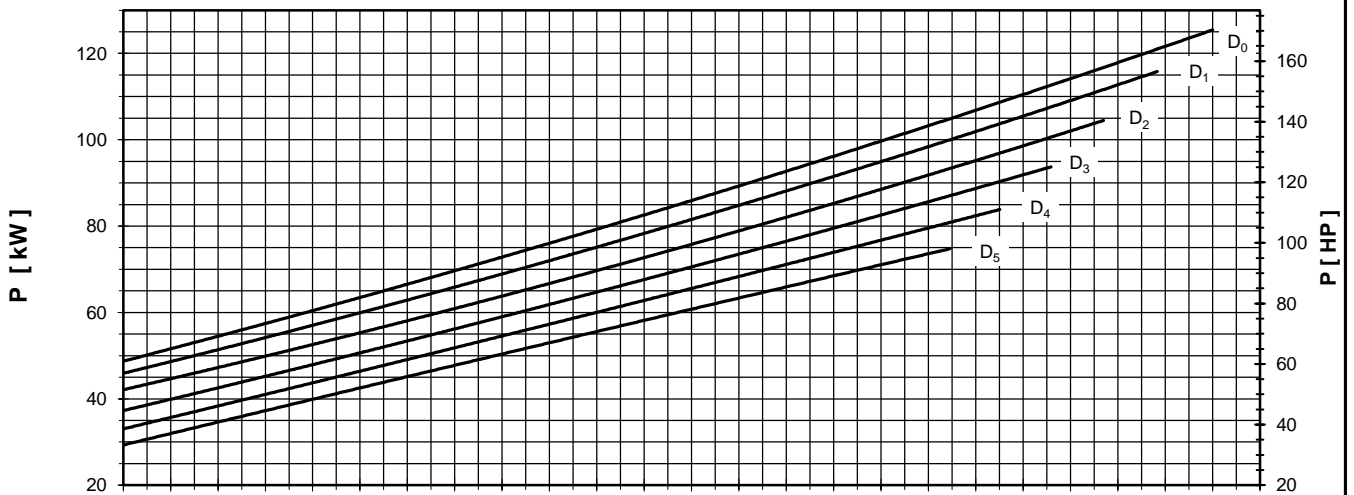
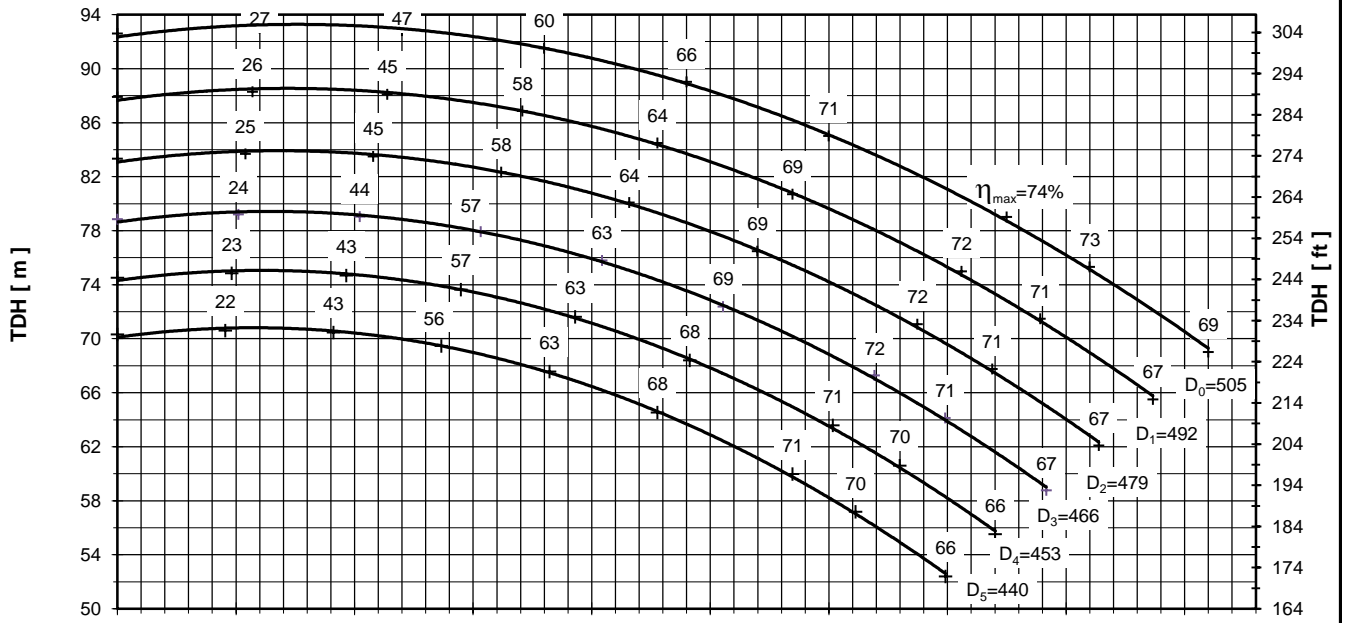

Performance curves are valid for clean cold water-kinematic viscosity 1 [mm²/s], density 1000 [kg/m³]. Methods and tolerances of presented performance curves are in accordance with ISO 9906 - Annex A

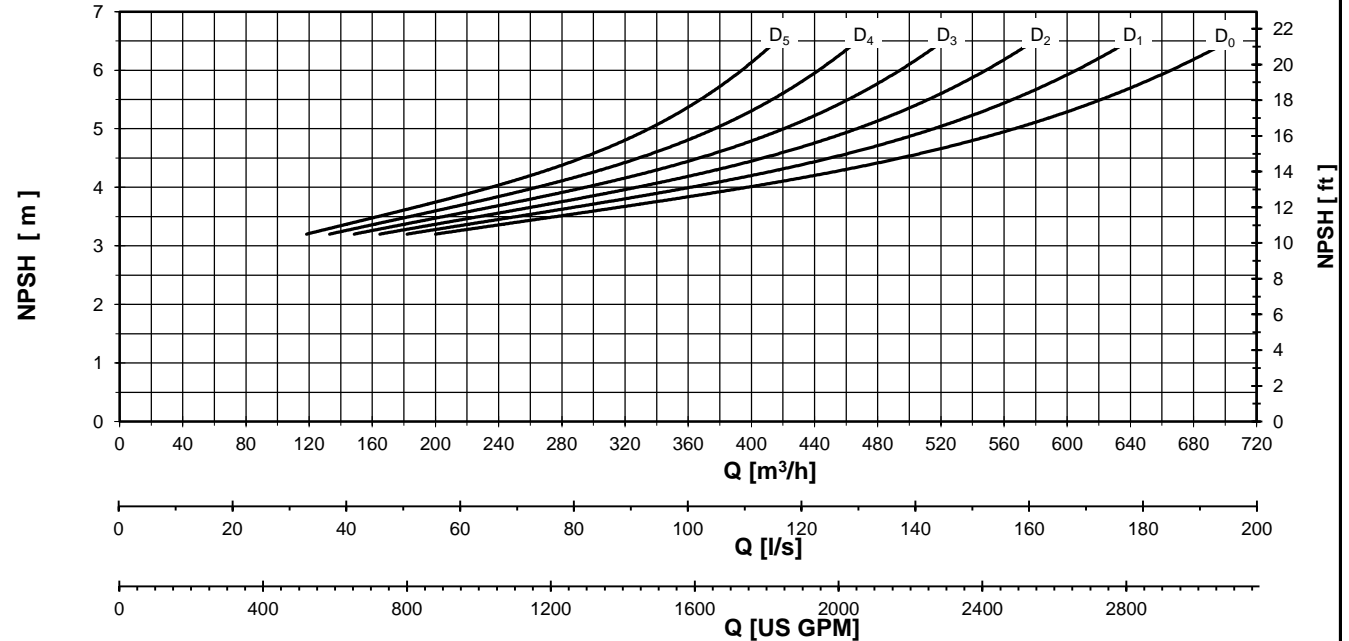
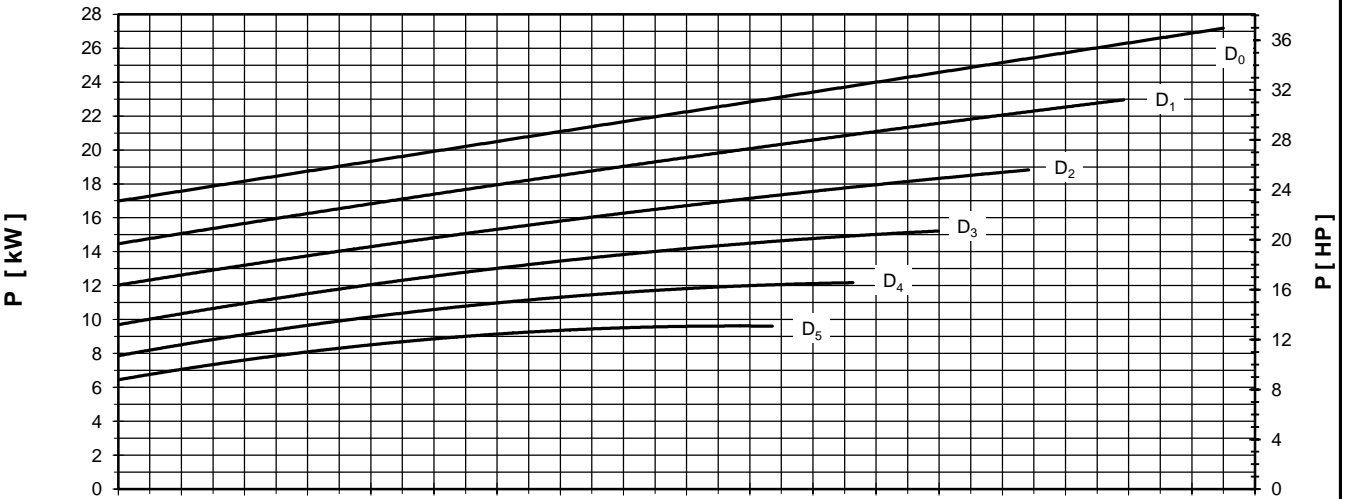
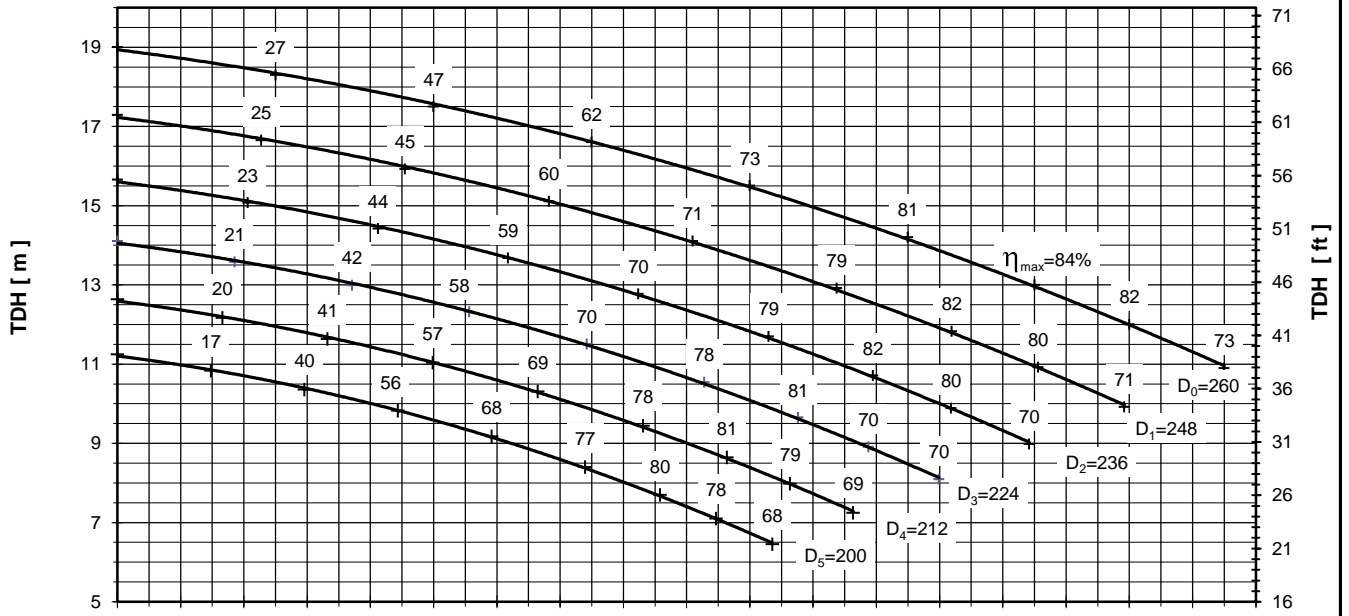

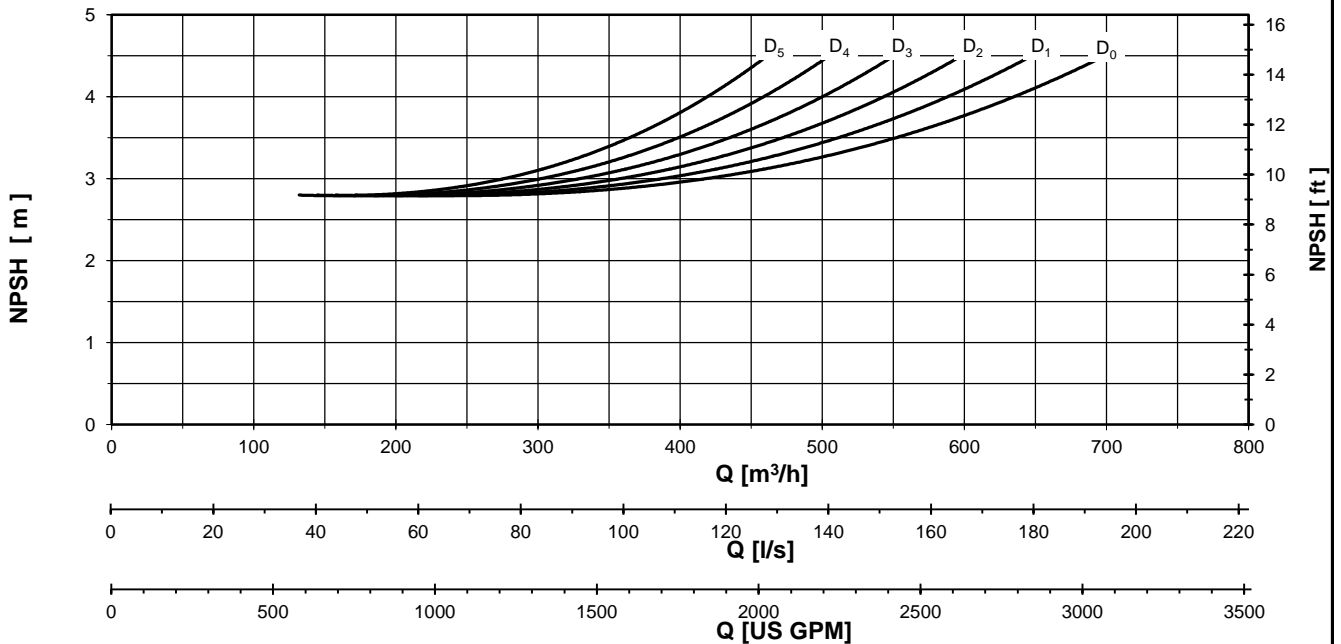
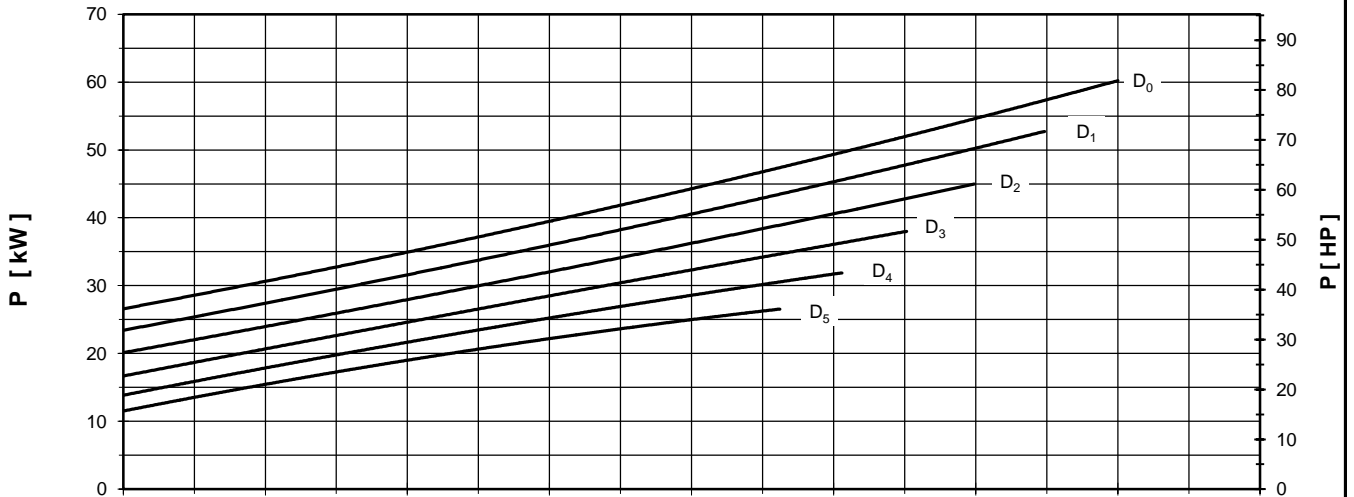
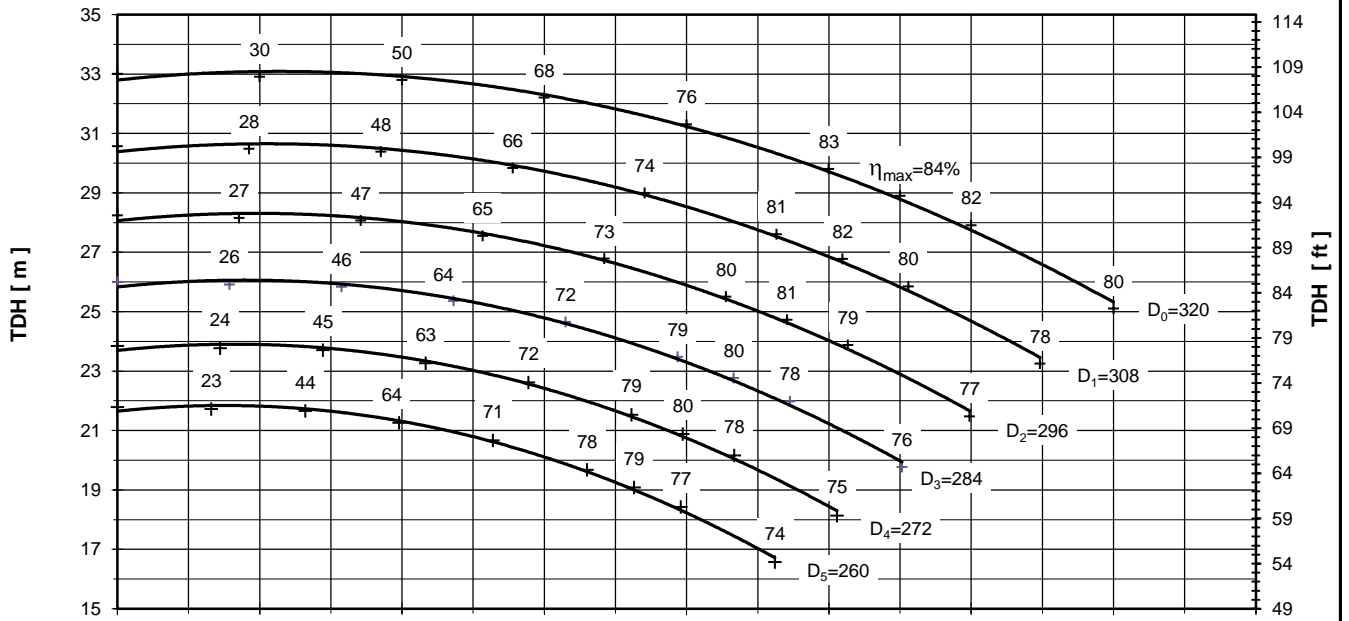

Performance curves are valid for clean cold water-kinematic viscosity 1 [mm²/s], density 1000 [kg/m³]. Methods and tolerances of presented performance curves are in accordance with ISO 9906 - Annex A





PUMP PERFORMANCE CURVES  
No. 4HD.0177.03

PUMP TYPE
SCP 200 - 400
1450 [rpm]

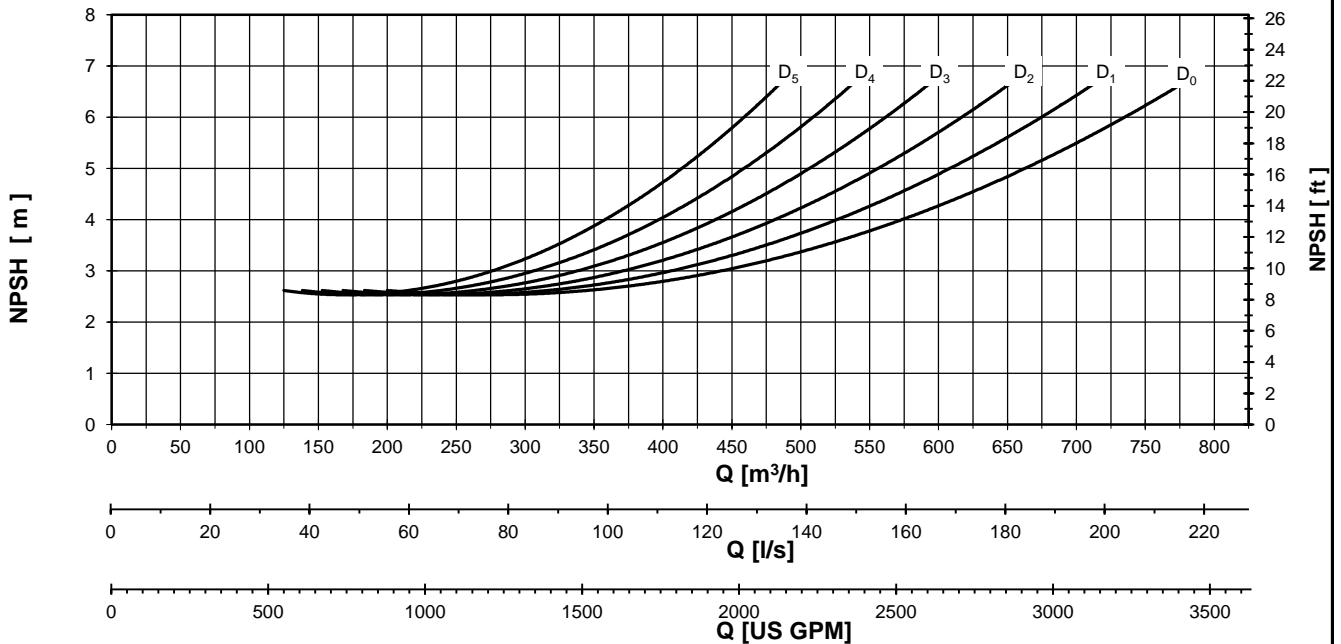
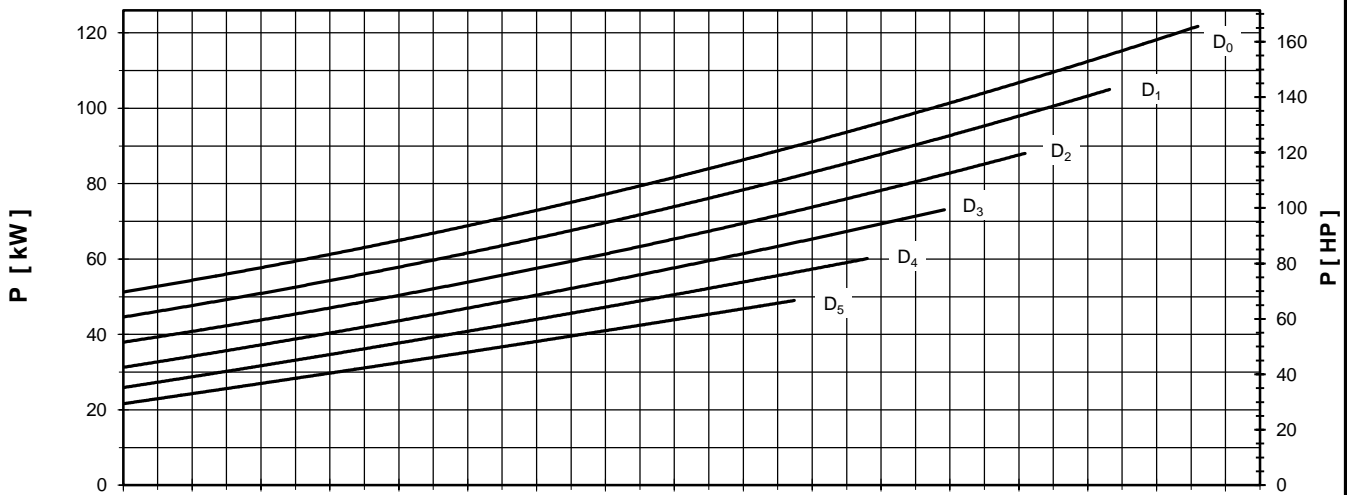
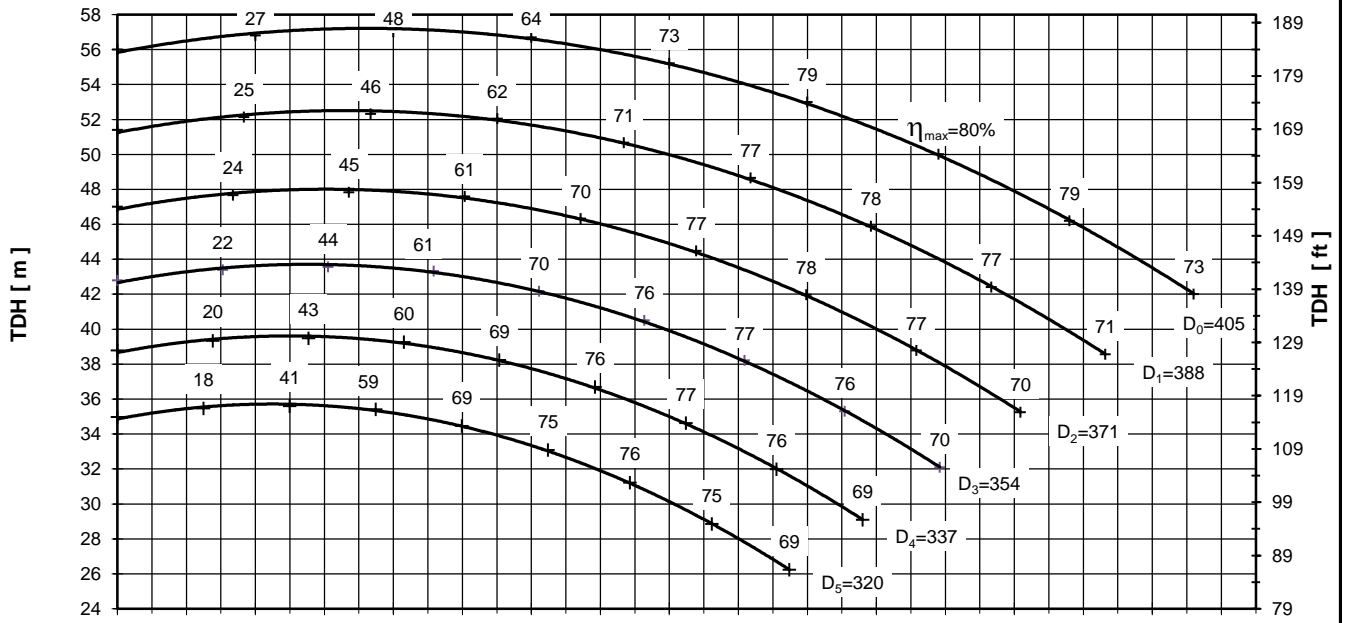

Performance curves are valid for clean cold water-kinematic viscosity 1 [mm<sup>2</sup>/s], density 1000 [kg/m<sup>3</sup>]. Methods and tolerances of presented performance curves are in accordance with ISO 9906 - Annex A



PUMP PERFORMANCE CURVES  
No. 4HD.0178.03

PUMP TYPE  
SCP 200 - 500  
1450 [rpm]

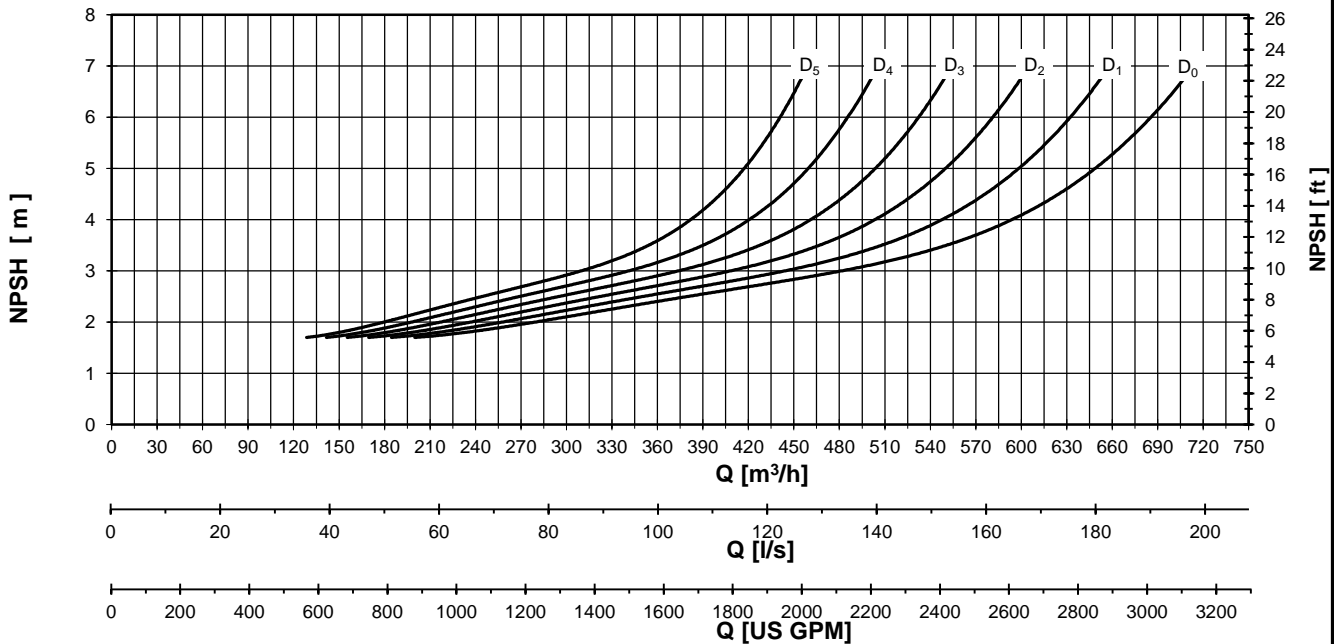
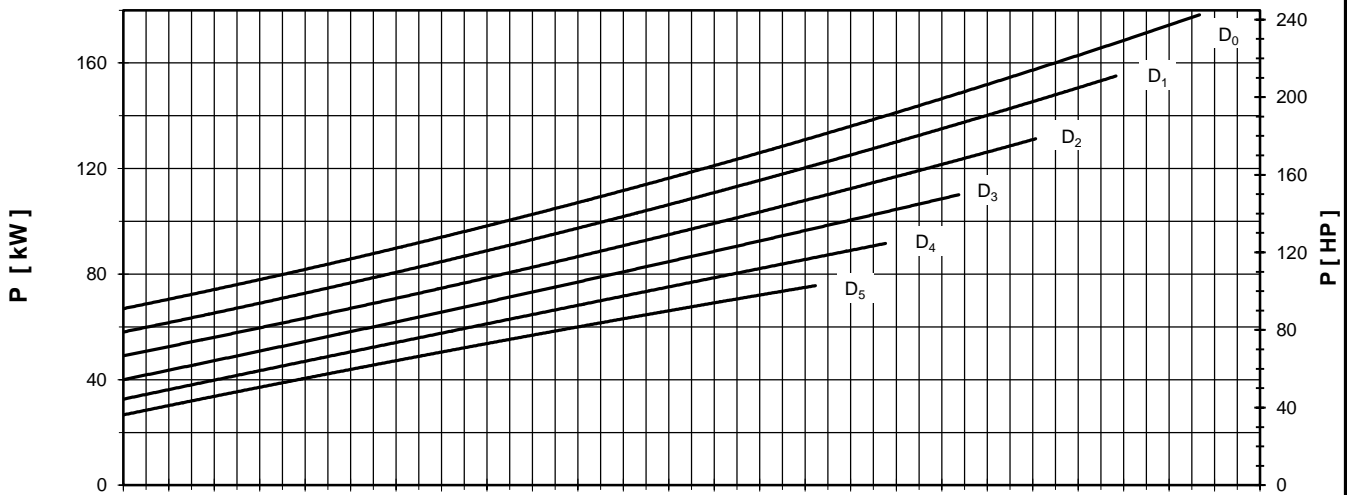
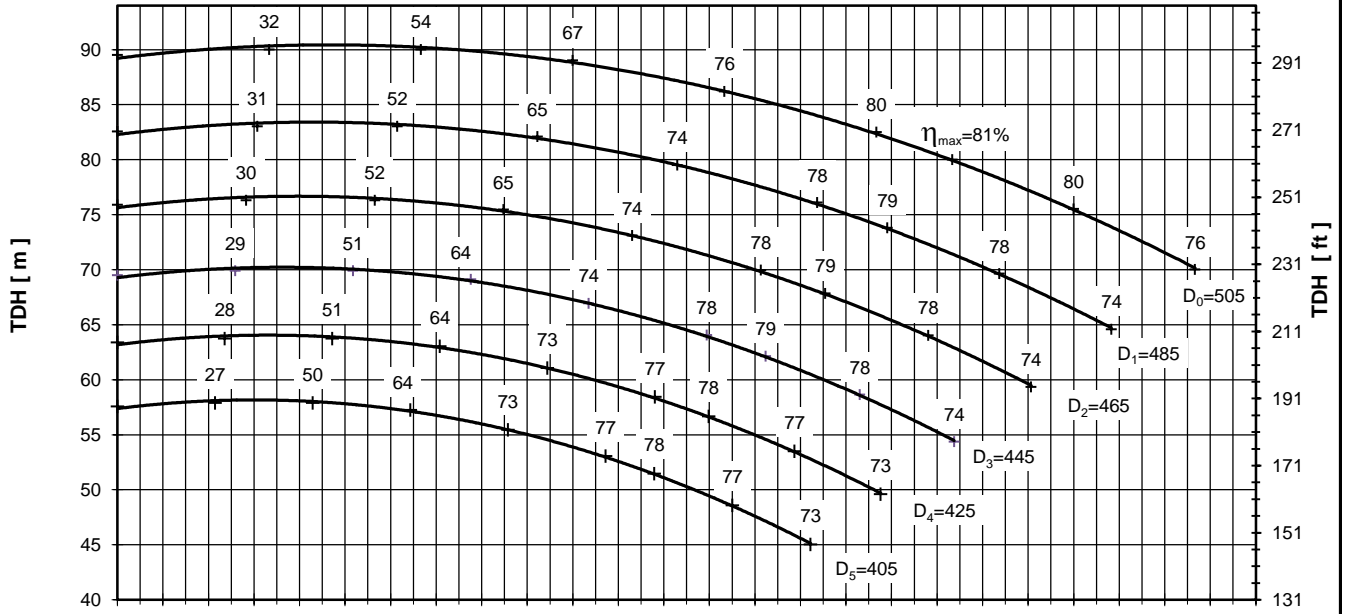

Performance curves are valid for clean cold water-kinematic viscosity 1 [mm<sup>2</sup>/s], density 1000 [kg/m<sup>3</sup>]. Methods and tolerances of presented performance curves are in accordance with ISO 9906 - Annex A



PUMP PERFORMANCE CURVES  
No. 4HD.0182.03

PUMP TYPE  
SCP 250 - 315  
1450 [rpm]

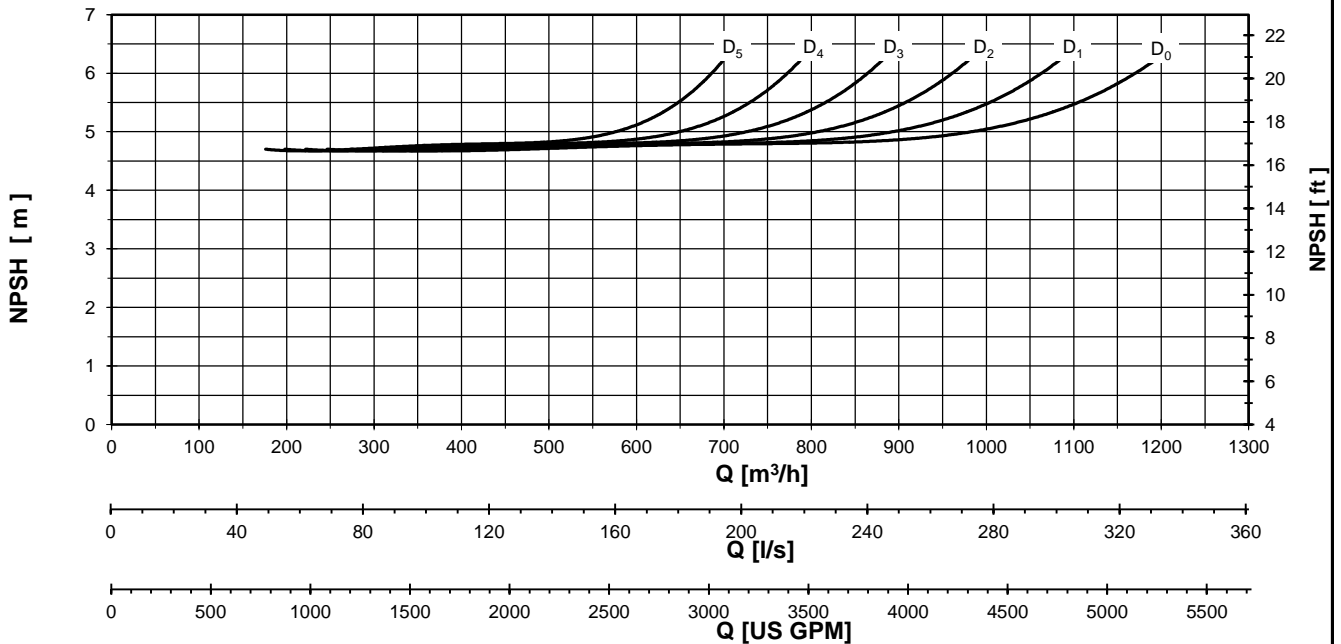
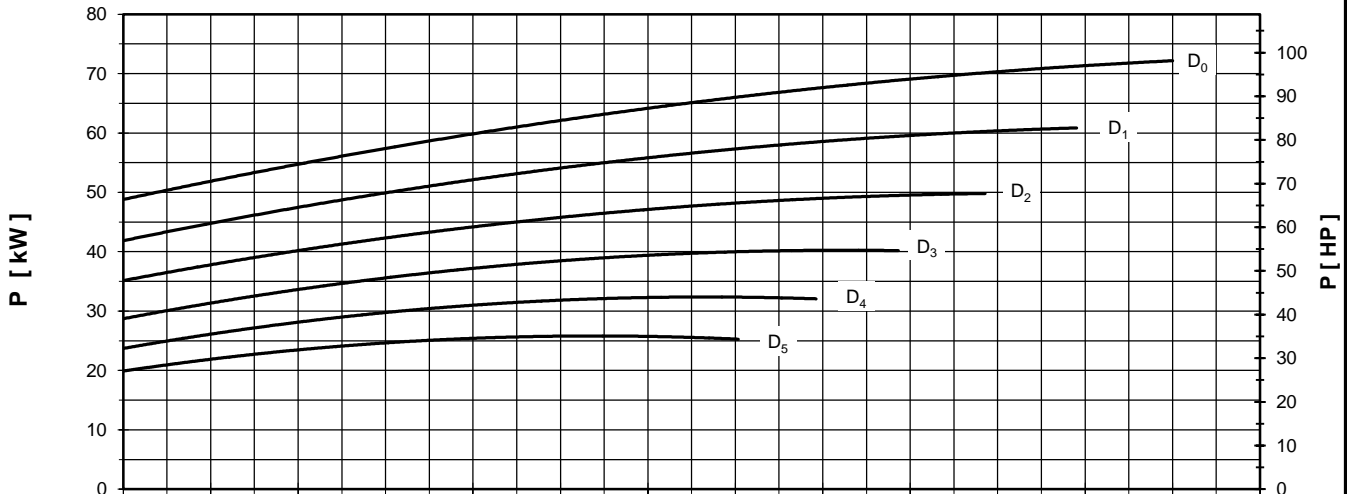
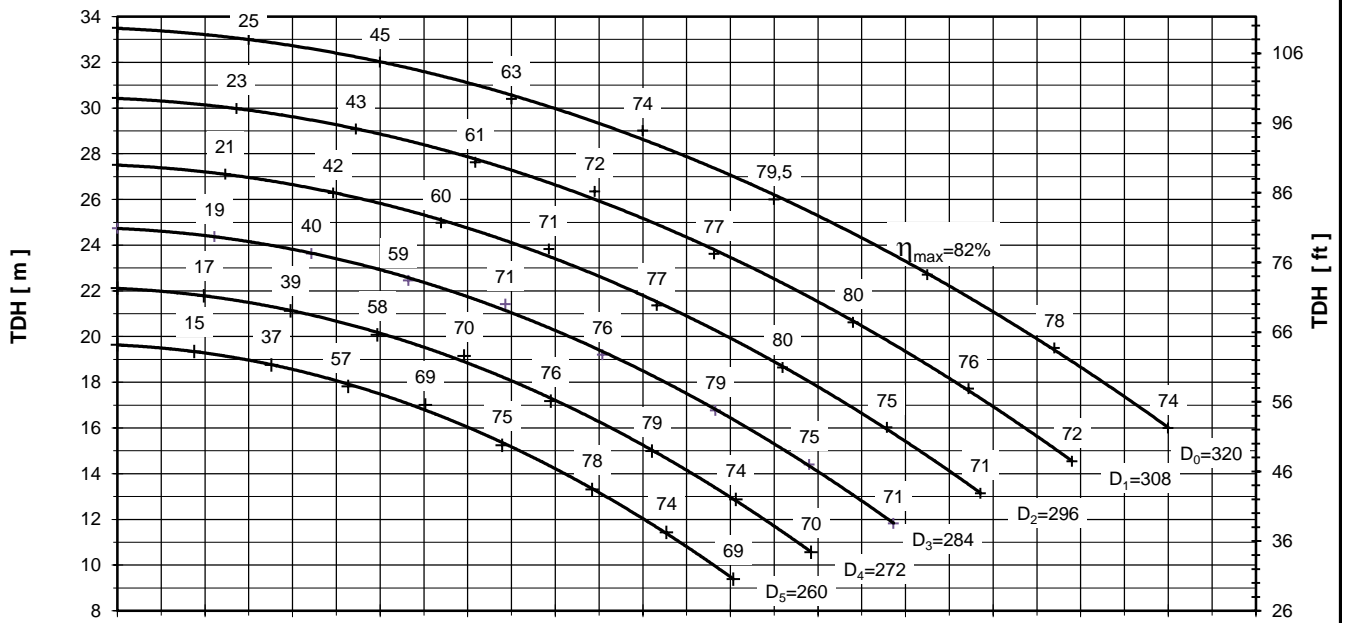

Performance curves are valid for clean cold water-kinematic viscosity 1 [mm²/s], density 1000 [kg/m³]. Methods and tolerances of presented performance curves are in accordance with ISO 9906 - Annex A

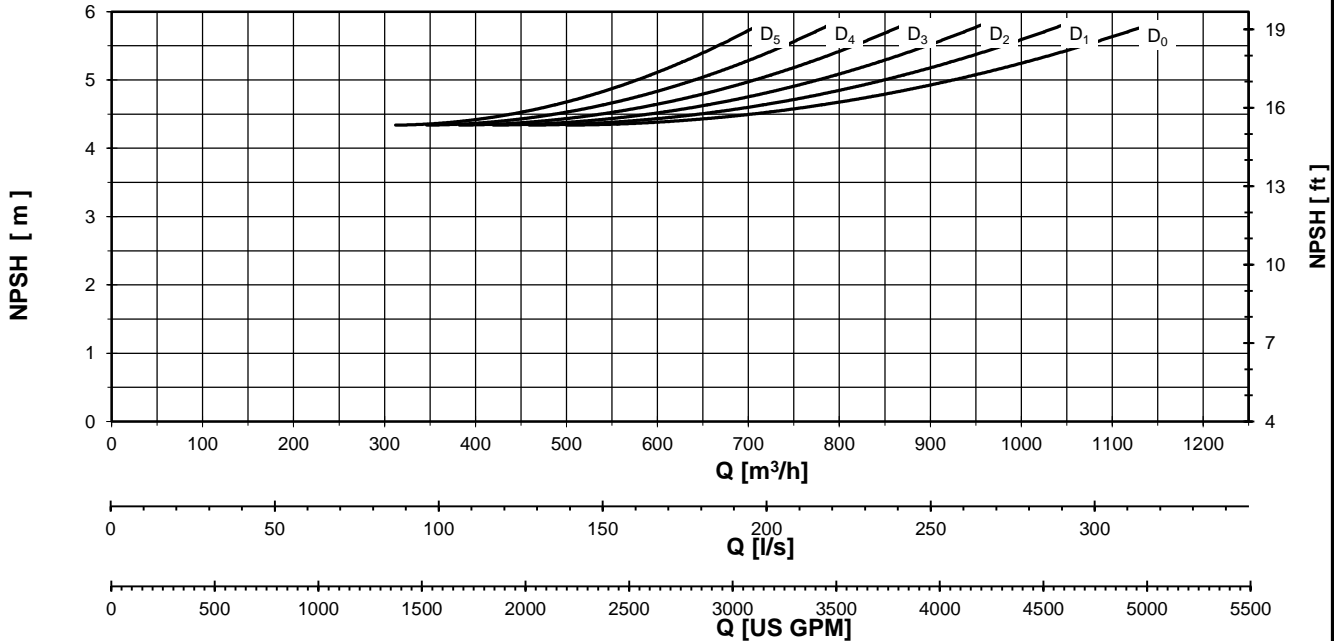
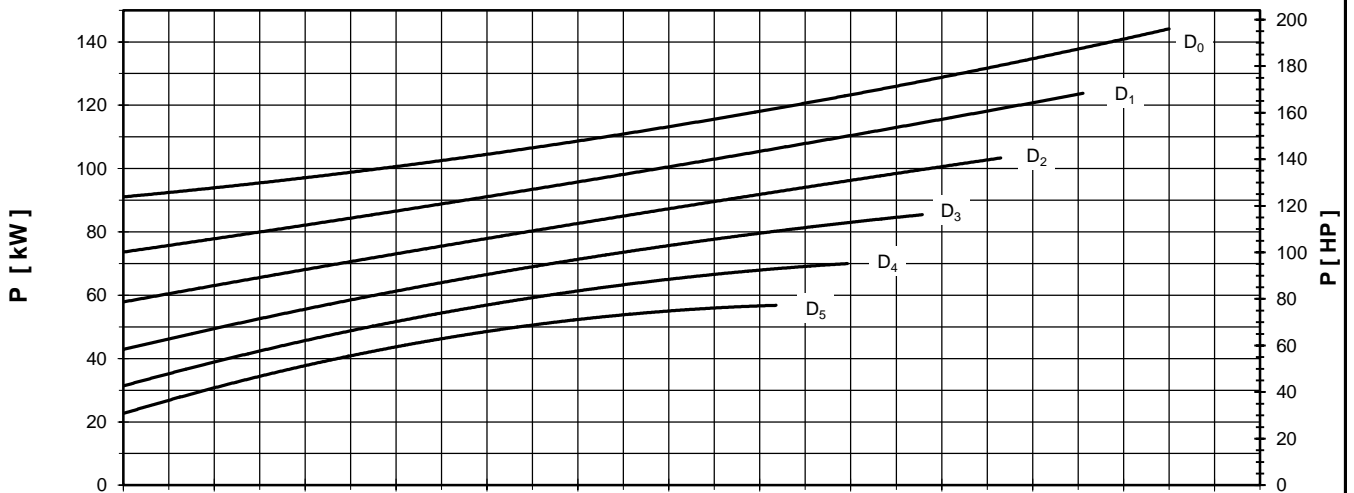
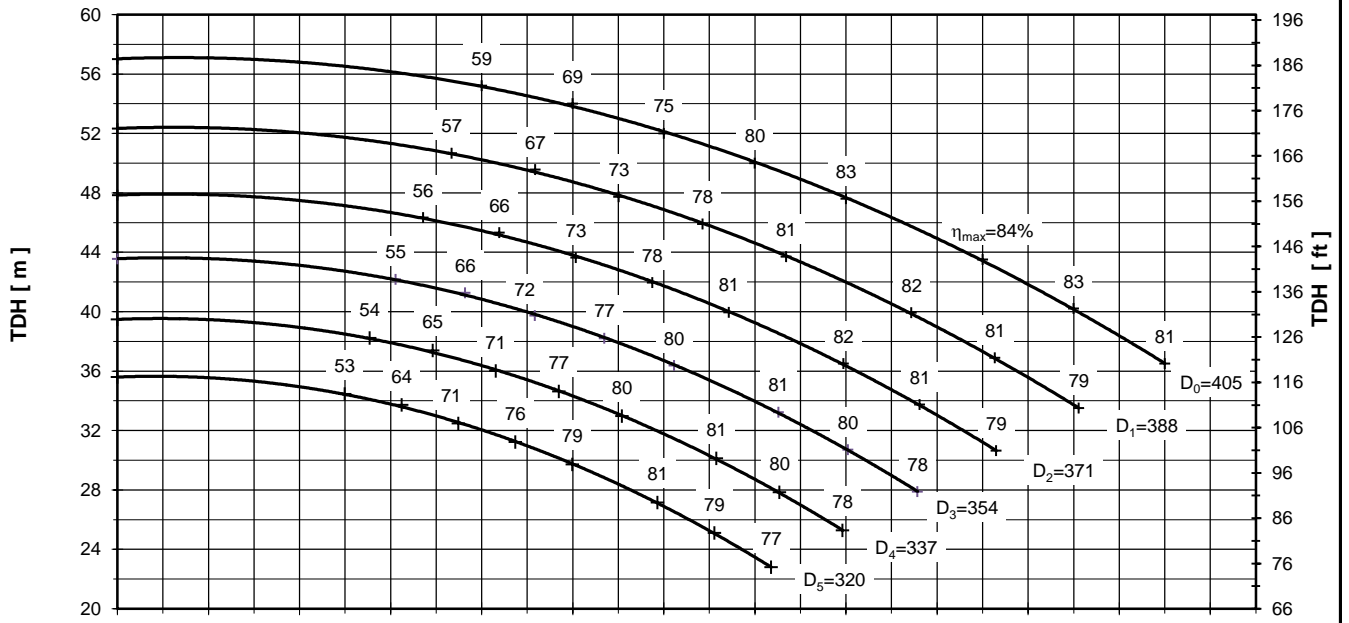

Performance curves are valid for clean cold water-kinematic viscosity 1 [mm²/s], density 1000 [kg/m³]. Methods and tolerances of presented performance curves are in accordance with ISO 9906 - Annex A



PUMP PERFORMANCE CURVES  
No. 4HD.0180.03

PUMP TYPE  
SCP 250 - 500  
1450 [rpm]

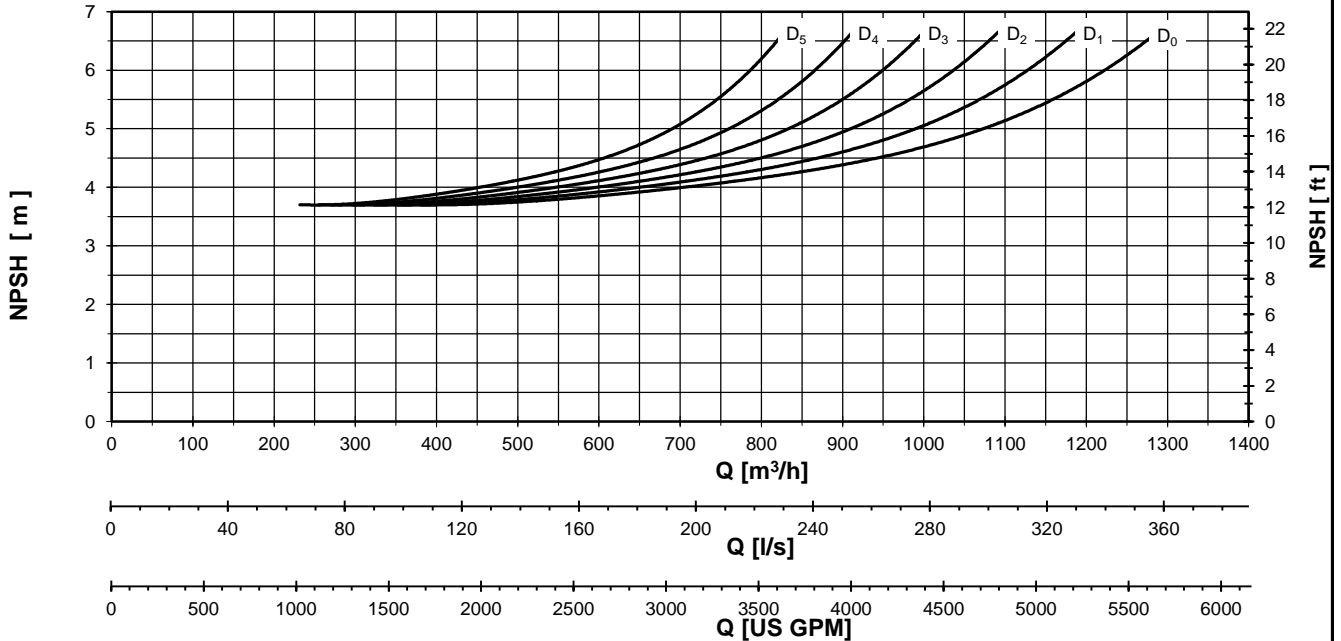
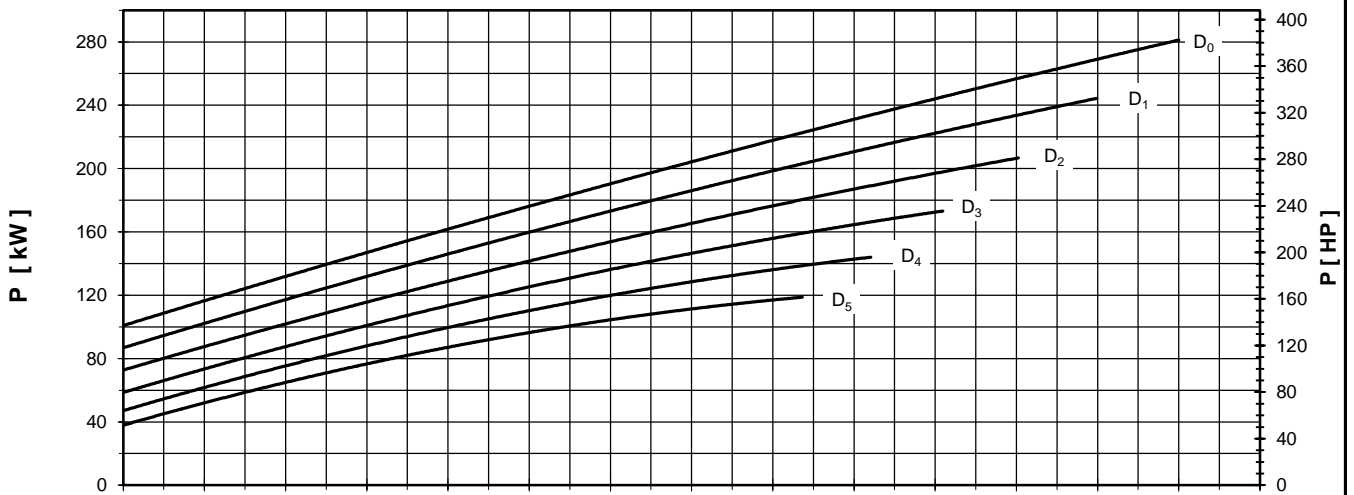
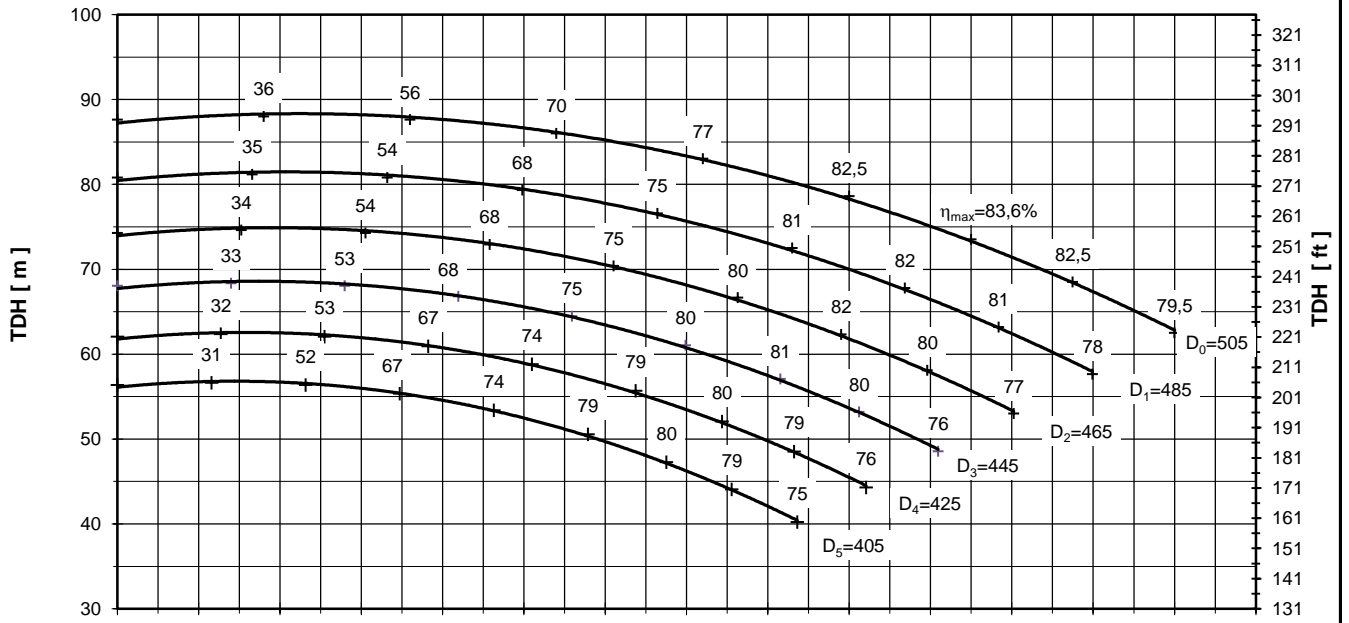

Performance curves are valid for clean cold water-kinematic viscosity 1 [mm²/s], density 1000 [kg/m³]. Methods and tolerances of presented performance curves are in accordance with ISO 9906 - Annex A

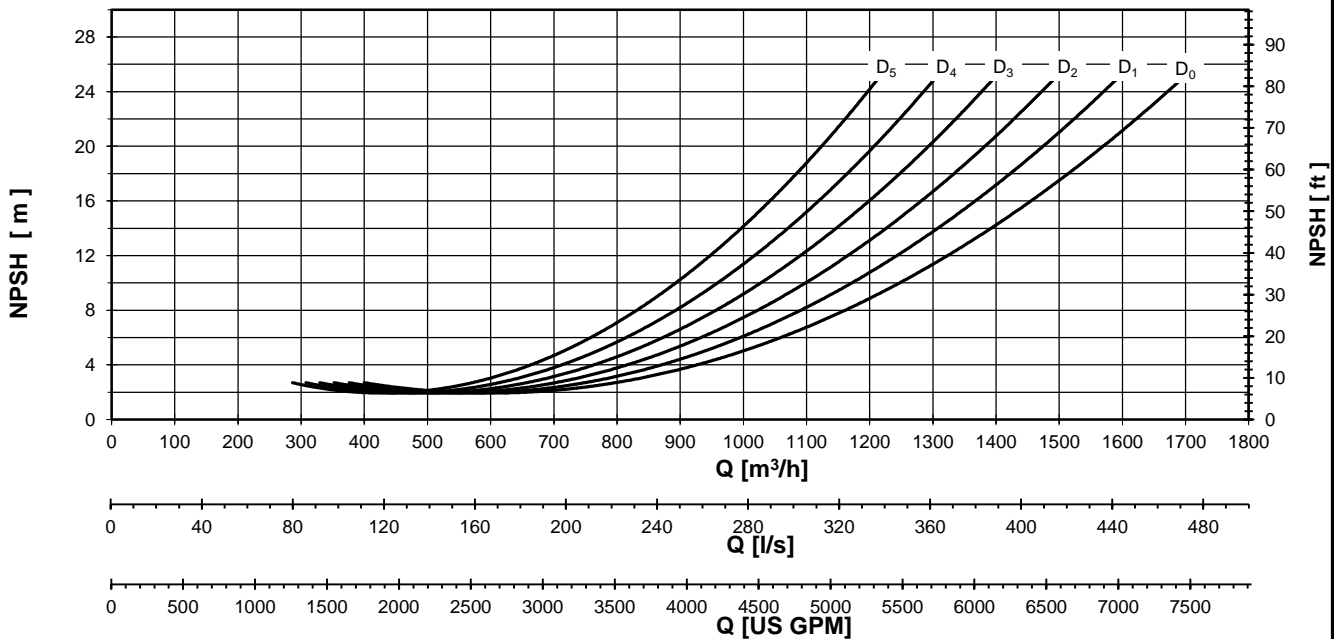
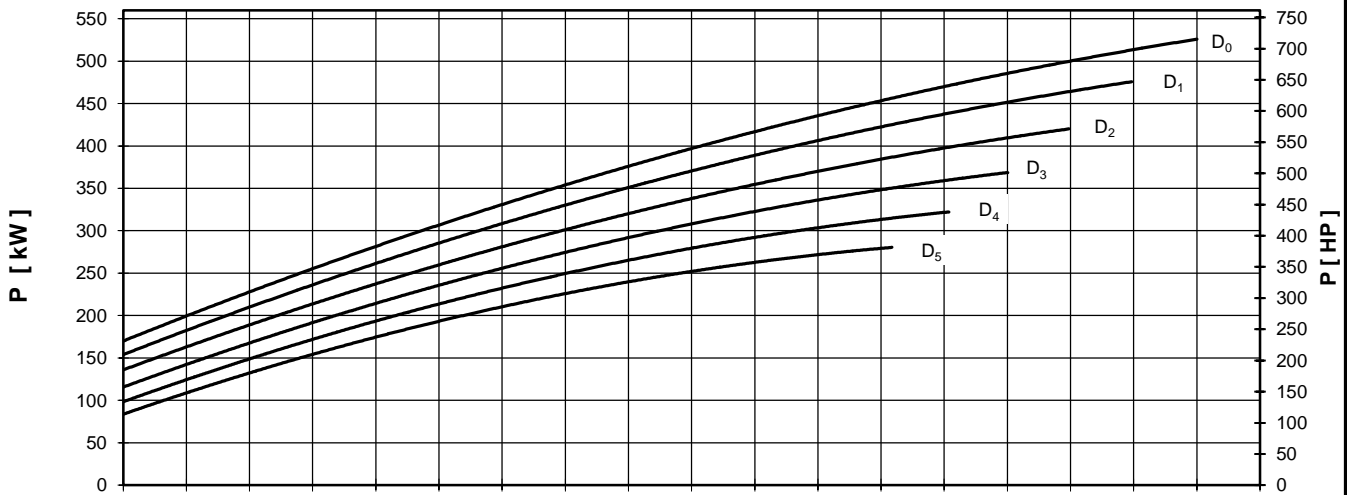
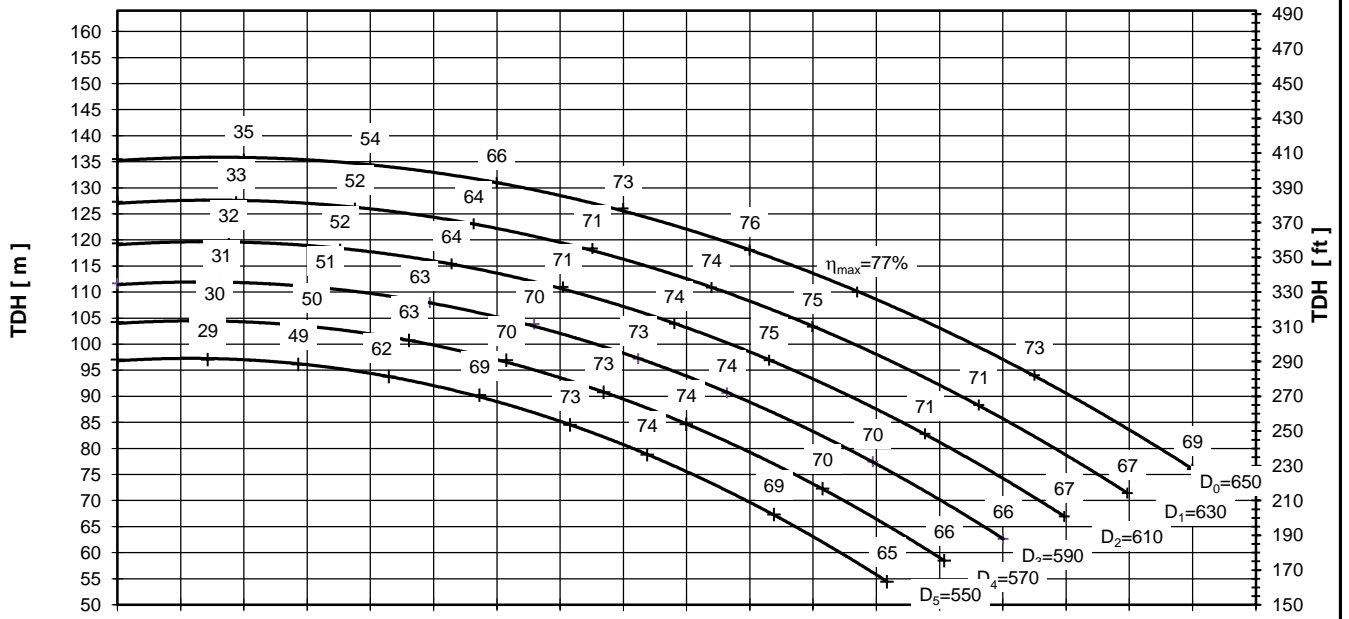

Performance curves are valid for clean cold water-kinematic viscosity 1 [mm²/s], density 1000 [kg/m³]. Methods and tolerances of presented performance curves are in accordance with ISO 9906 - Annex A



PUMP PERFORMANCE CURVES  
No. 4HD.0184.03

PUMP TYPE  
SCP 250 - 710  
1450 [rpm]

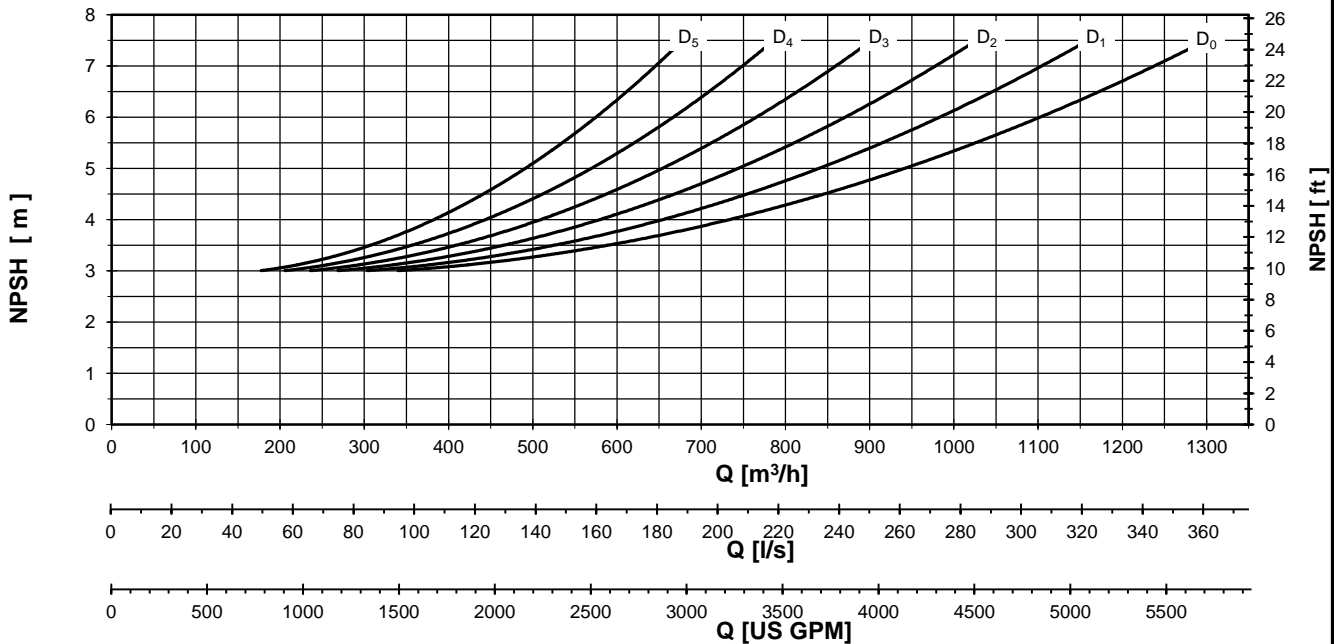
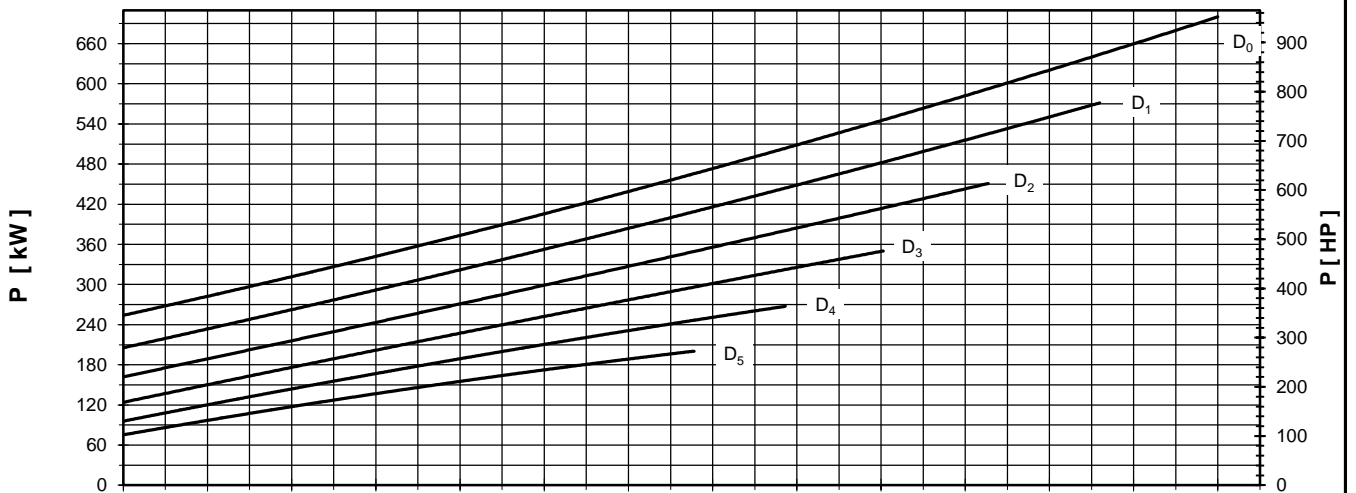
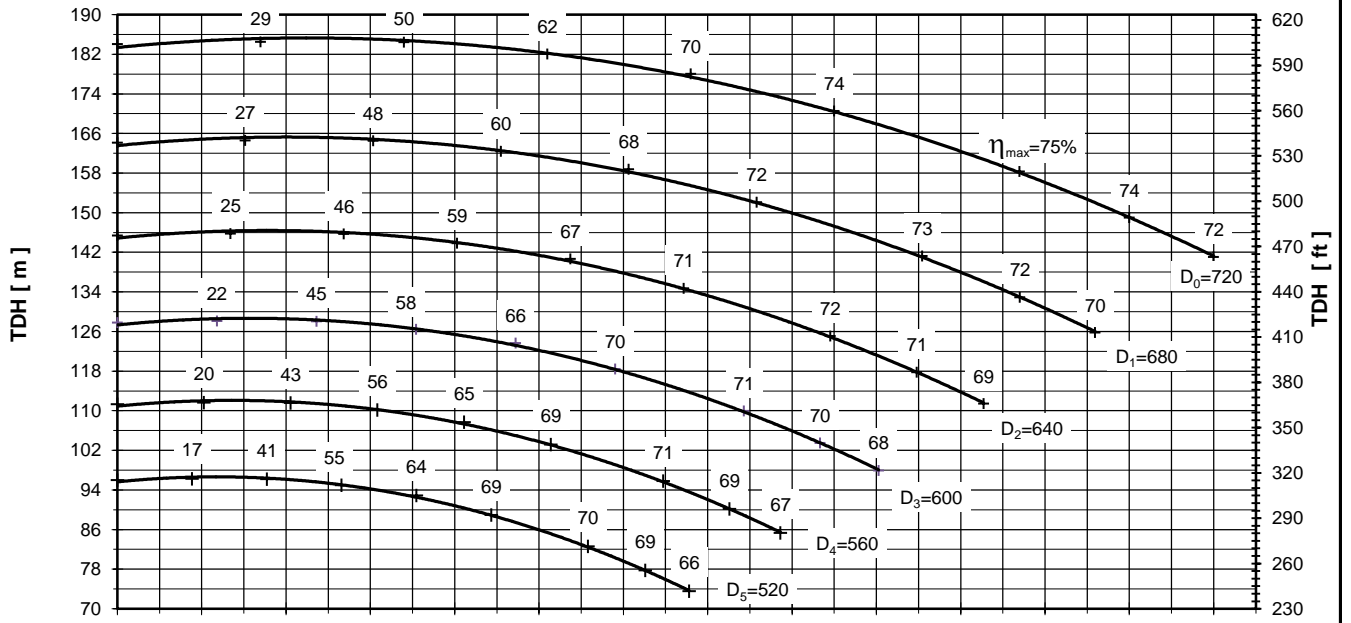

Performance curves are valid for clean cold water-kinematic viscosity 1 [mm²/s], density 1000 [kg/m³]. Methods and tolerances of presented performance curves are in accordance with ISO 9906 - Annex A



PUMP PERFORMANCE CURVES  
No. 4HD.0185.03

PUMP TYPE  
SCP 300 - 400  
1450 [rpm]

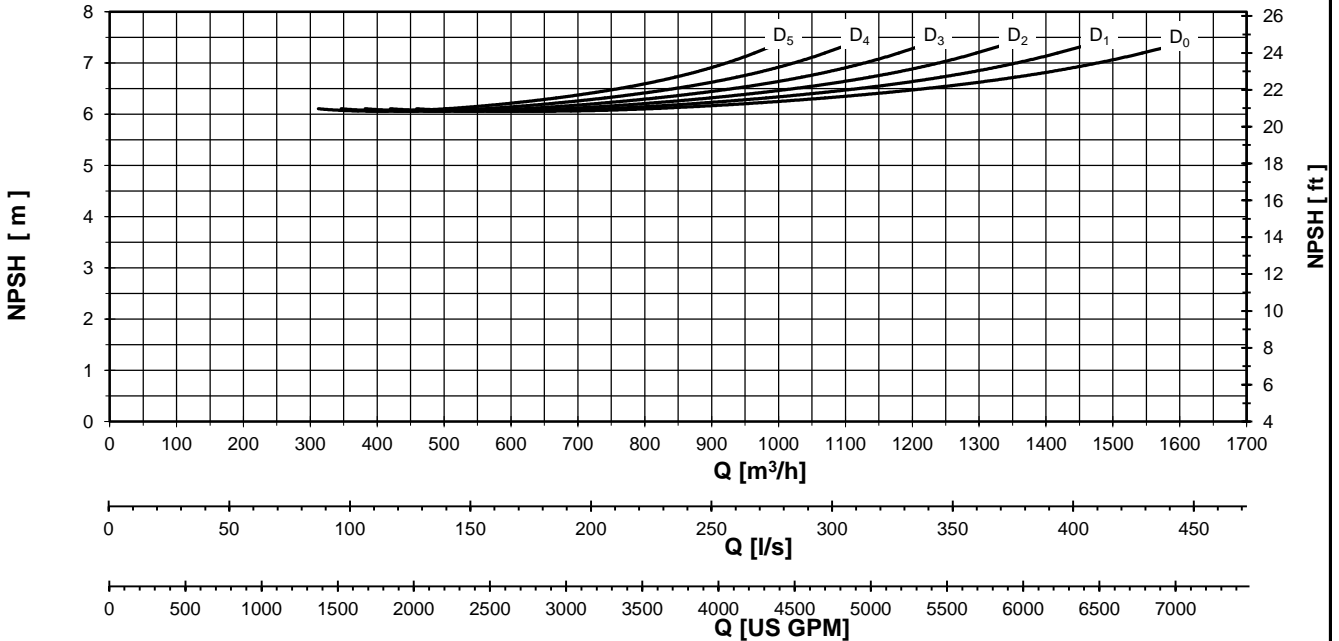
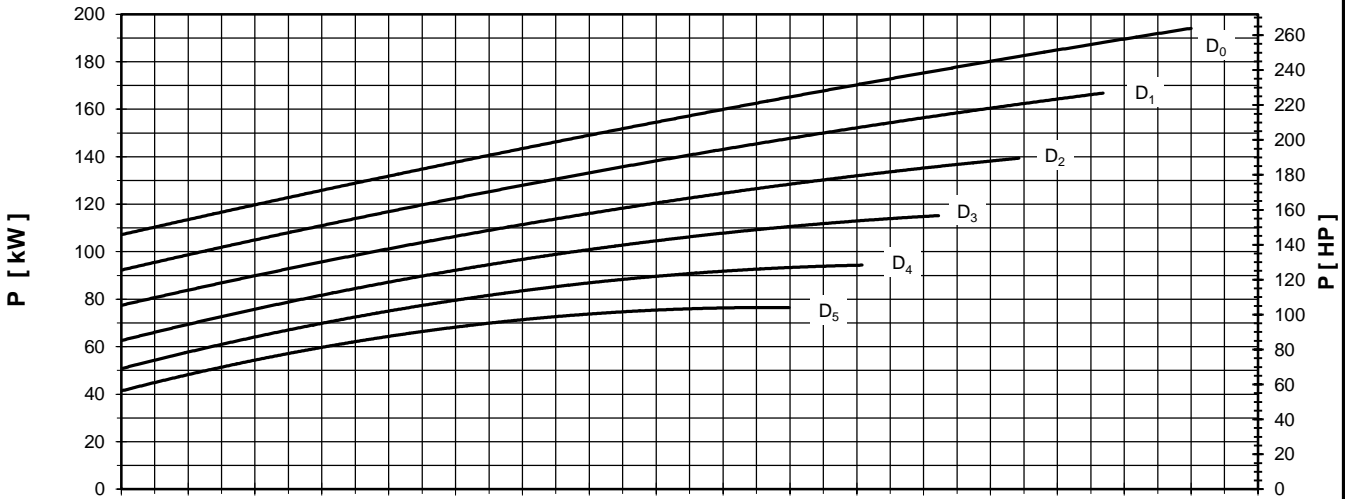
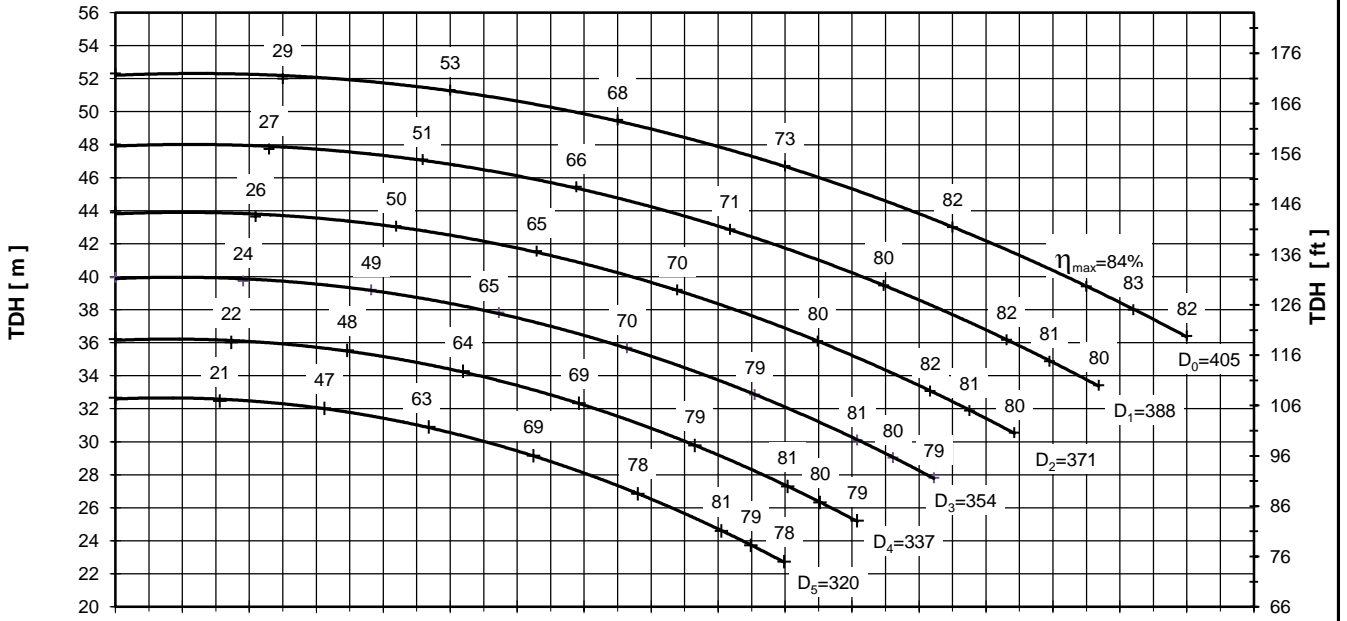

Performance curves are valid for clean cold water-kinematic viscosity 1 [mm²/s], density 1000 [kg/m³]. Methods and tolerances of presented performance curves are in accordance with ISO 9906 - Annex A



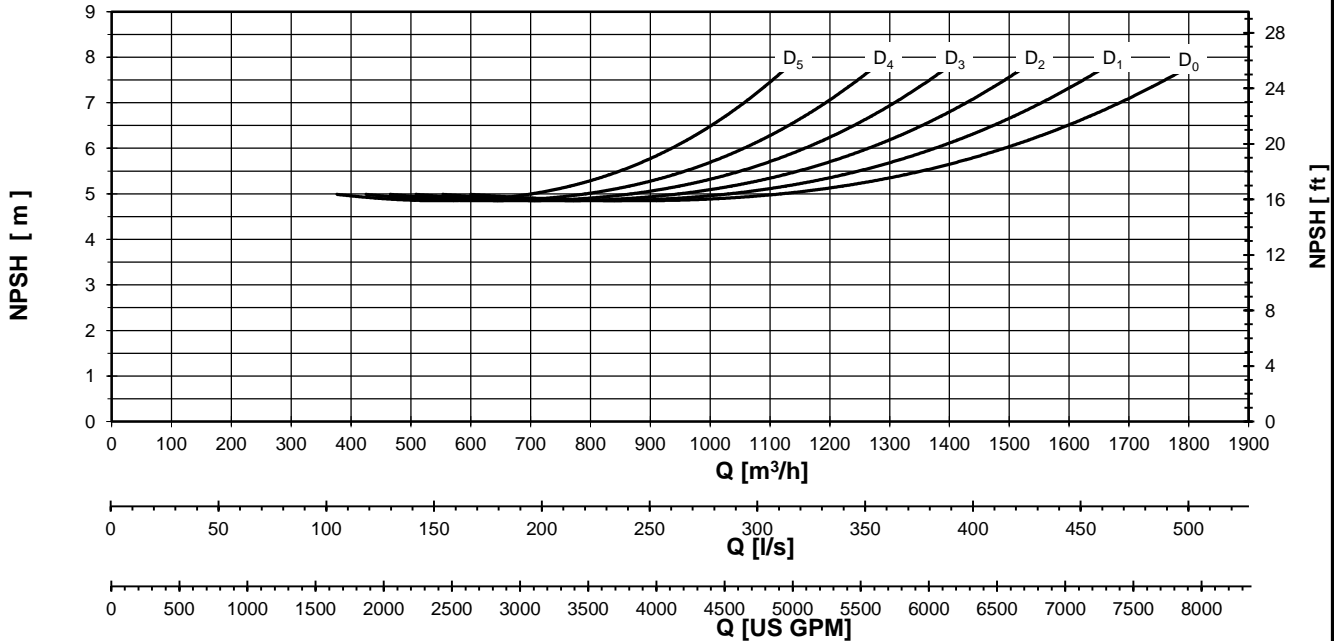
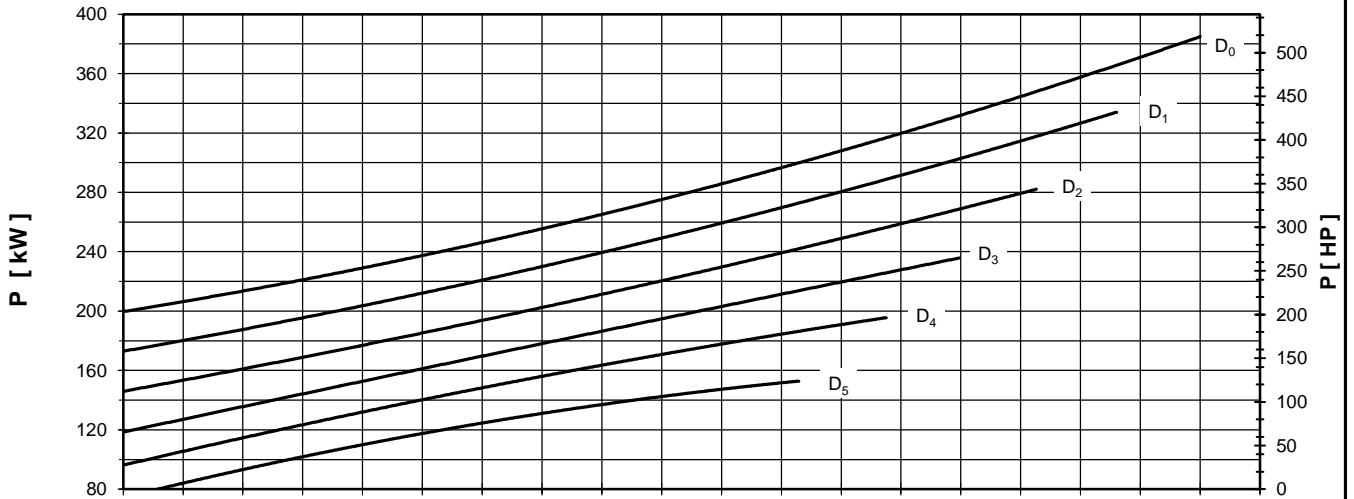
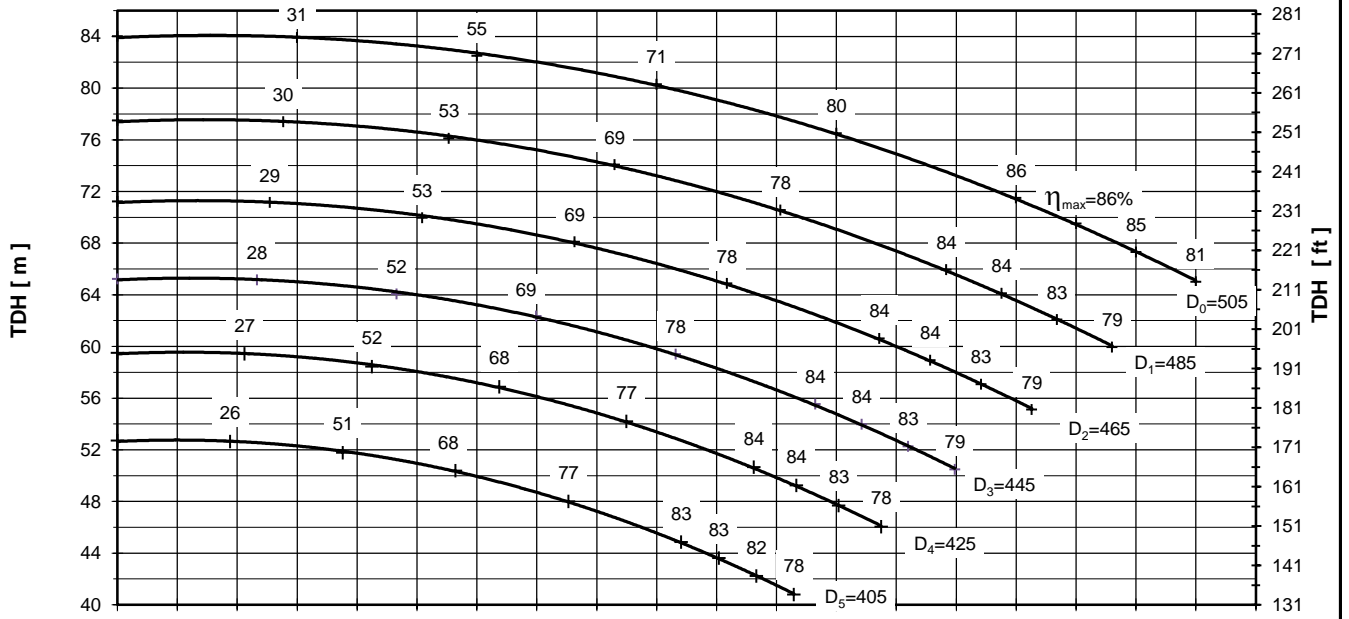

Performance curves are valid for clean cold water-kinematic viscosity 1 [mm²/s], density 1000 [kg/m³]. Methods and tolerances of presented performance curves are in accordance with ISO 9906 - Annex A

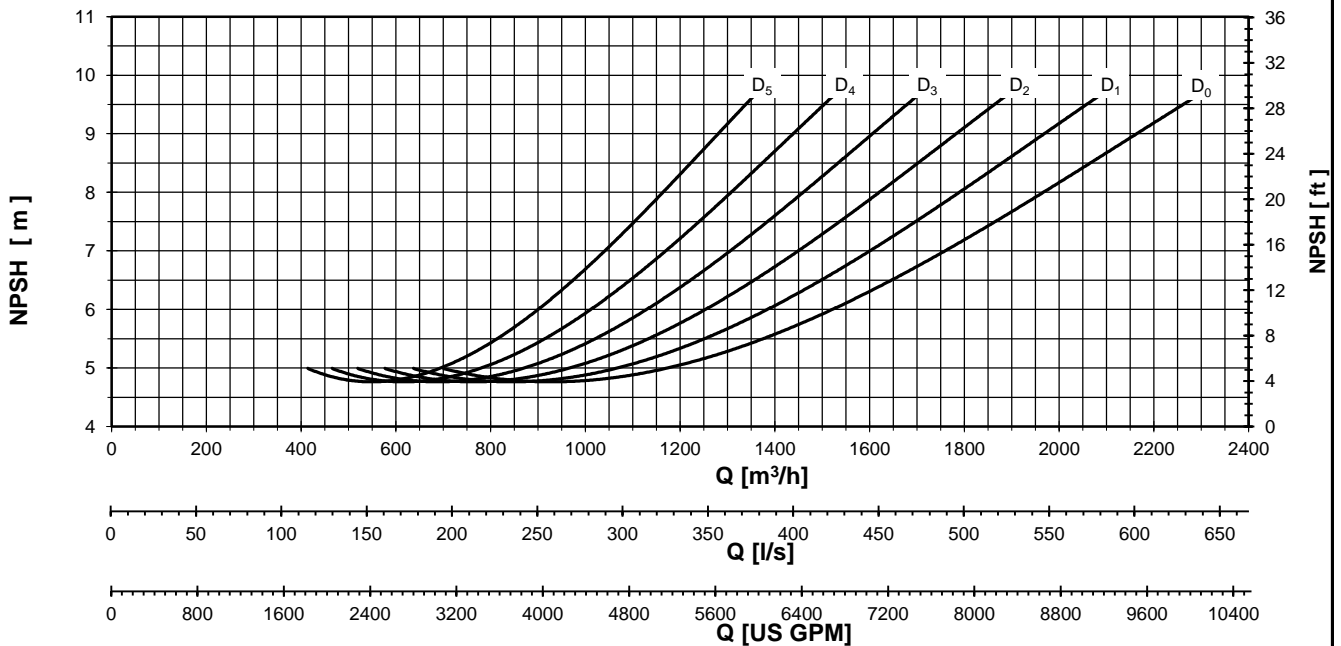
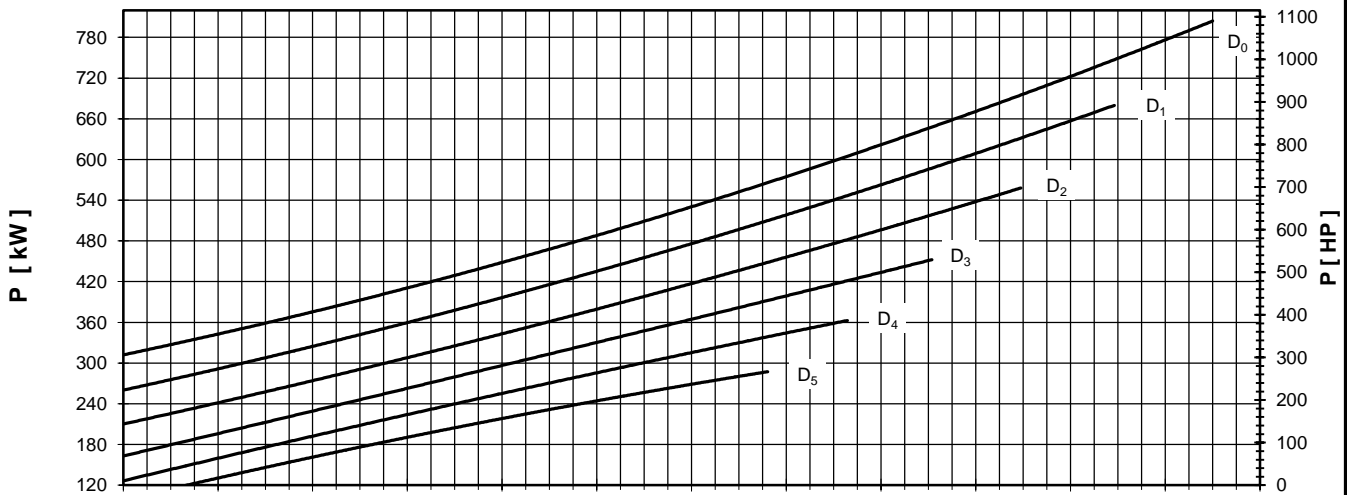
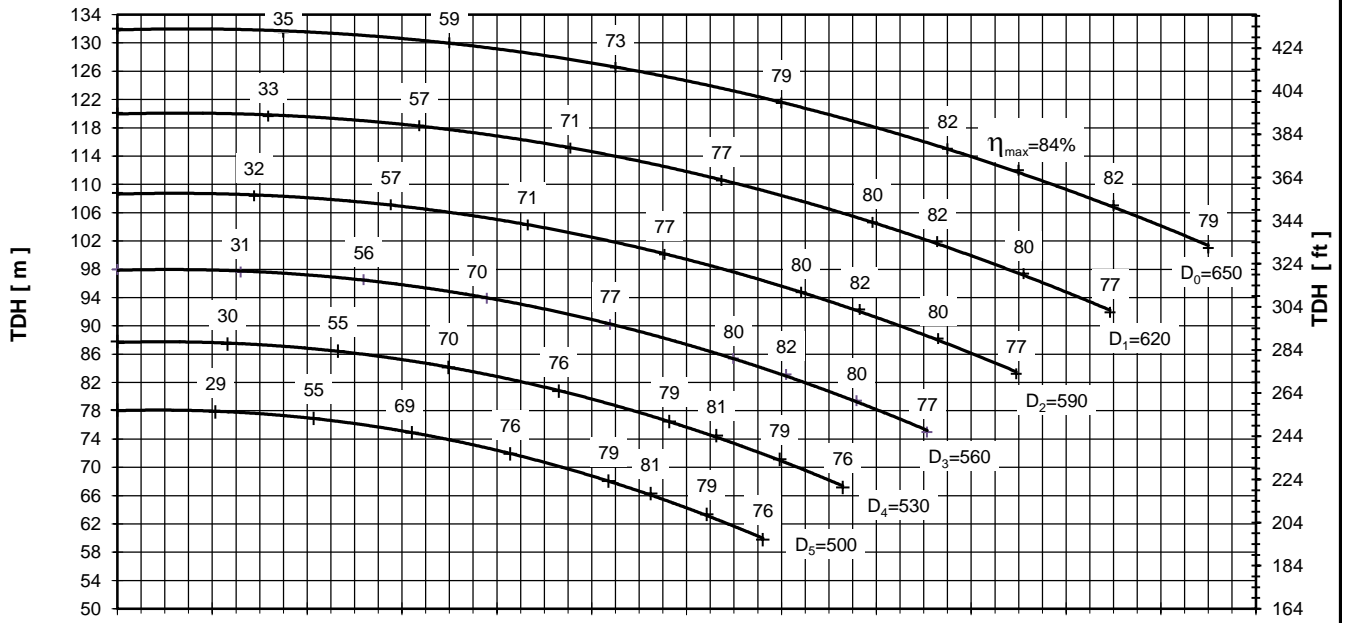

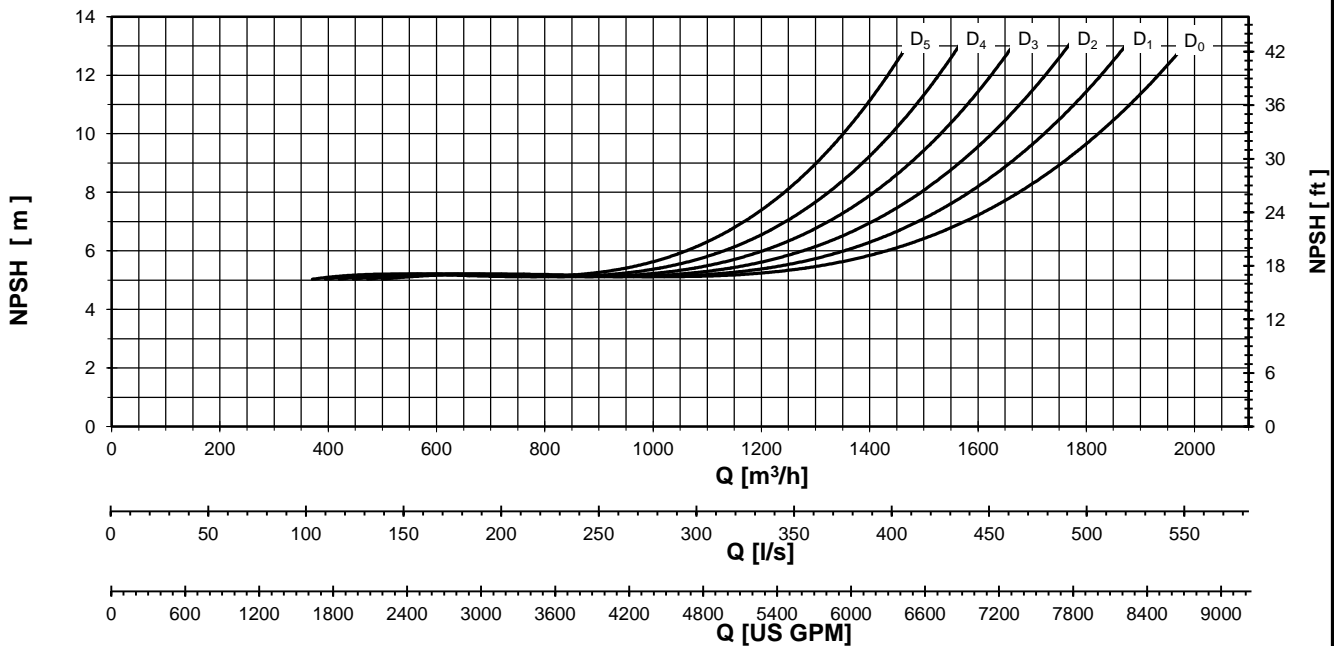
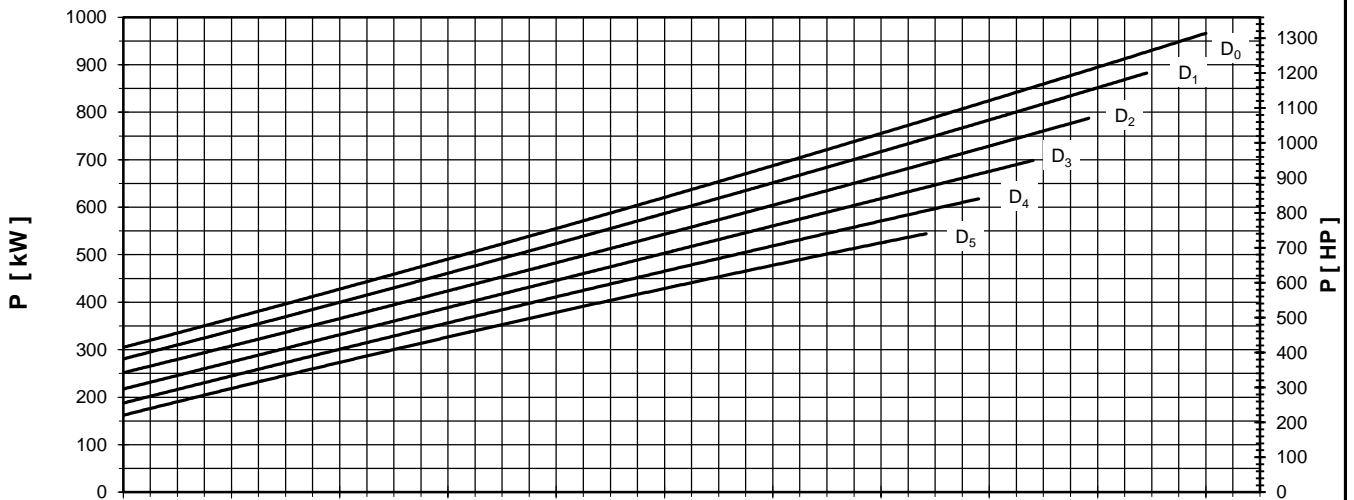
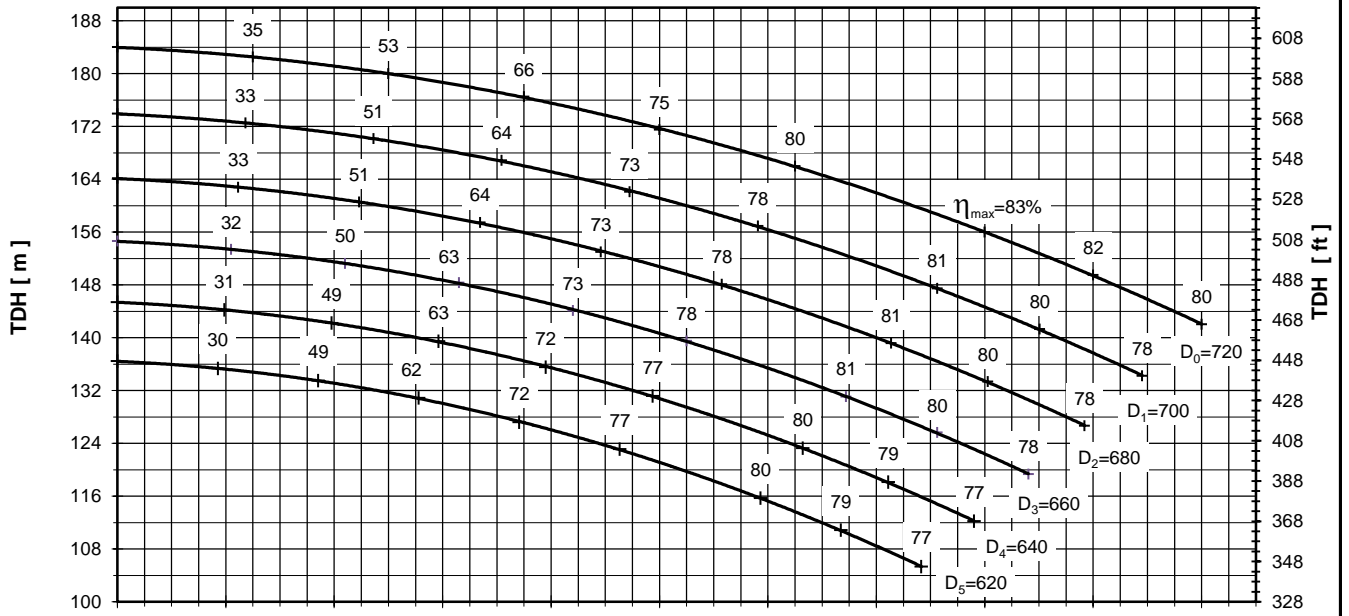



PUMP PERFORMANCE CURVES  
No. 4HD.0189.03

PUMP TYPE  
SCP 350 - 400  
1450 [rpm]

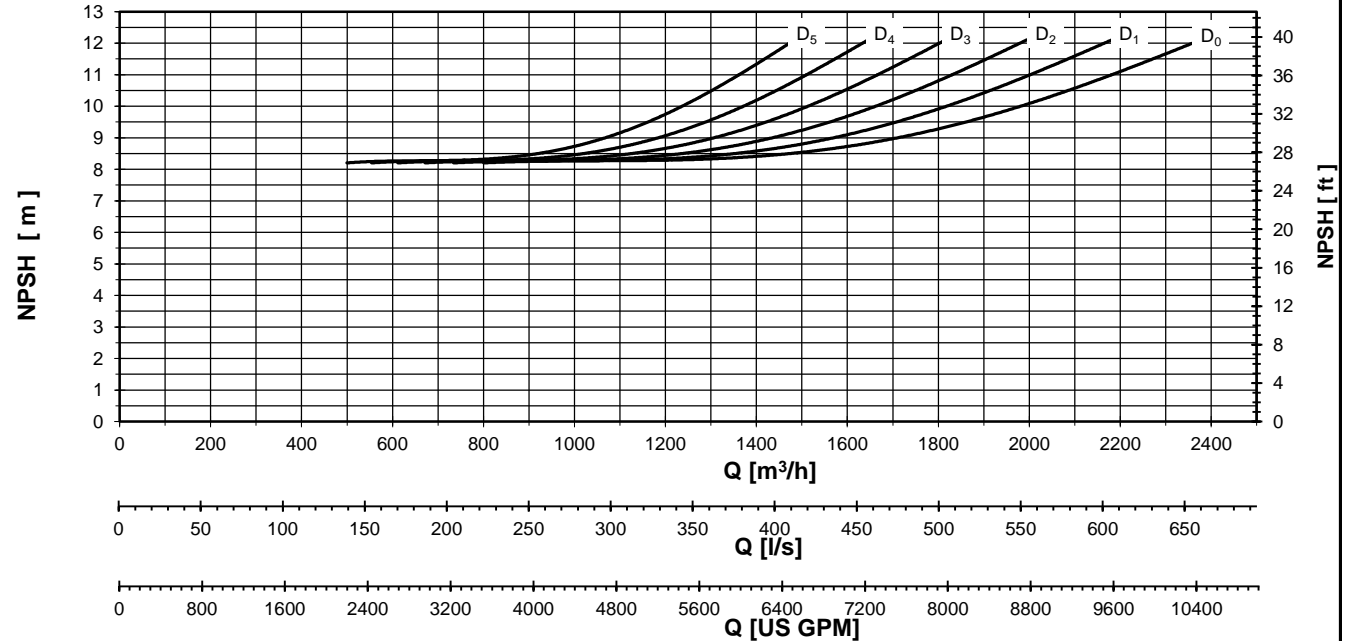
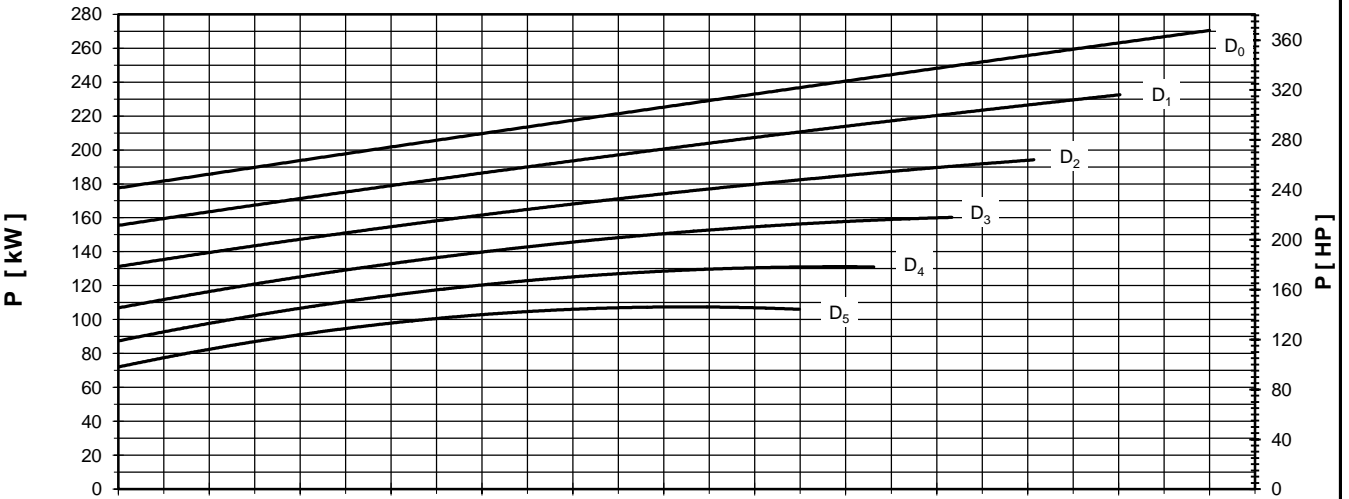
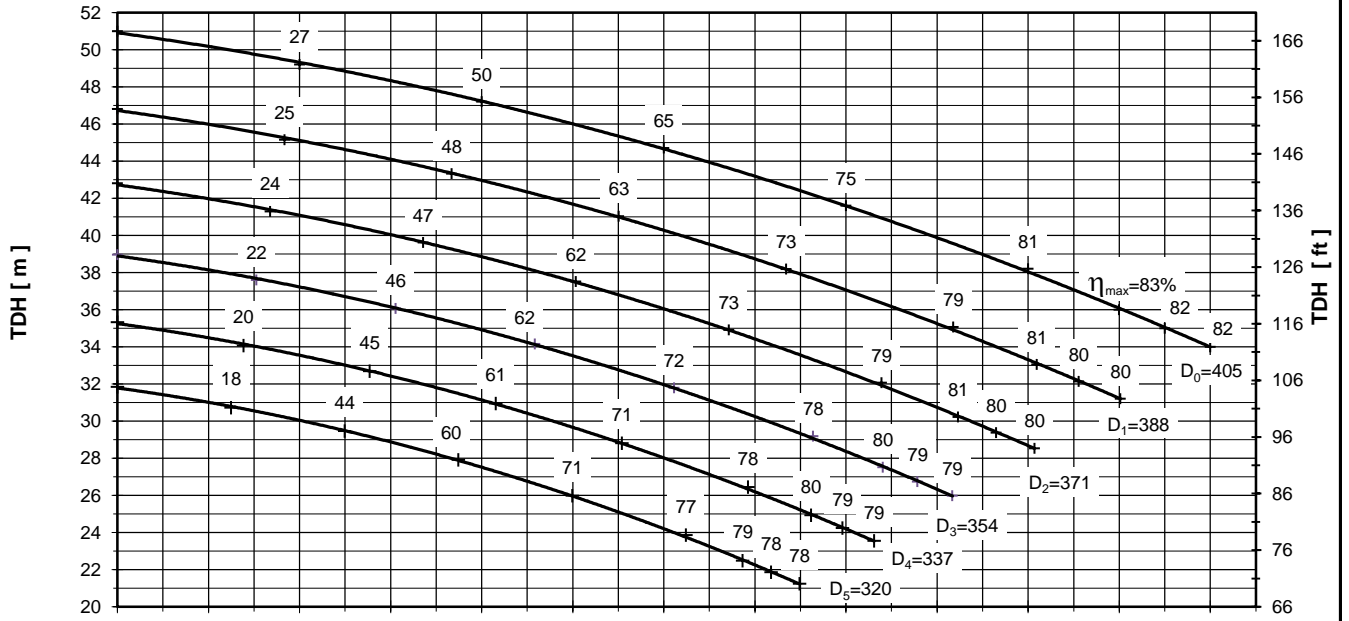

Performance curves are valid for clean cold water-kinematic viscosity 1 [mm²/s], density 1000 [kg/m³]. Methods and tolerances of presented performance curves are in accordance with ISO 9906 - Annex A

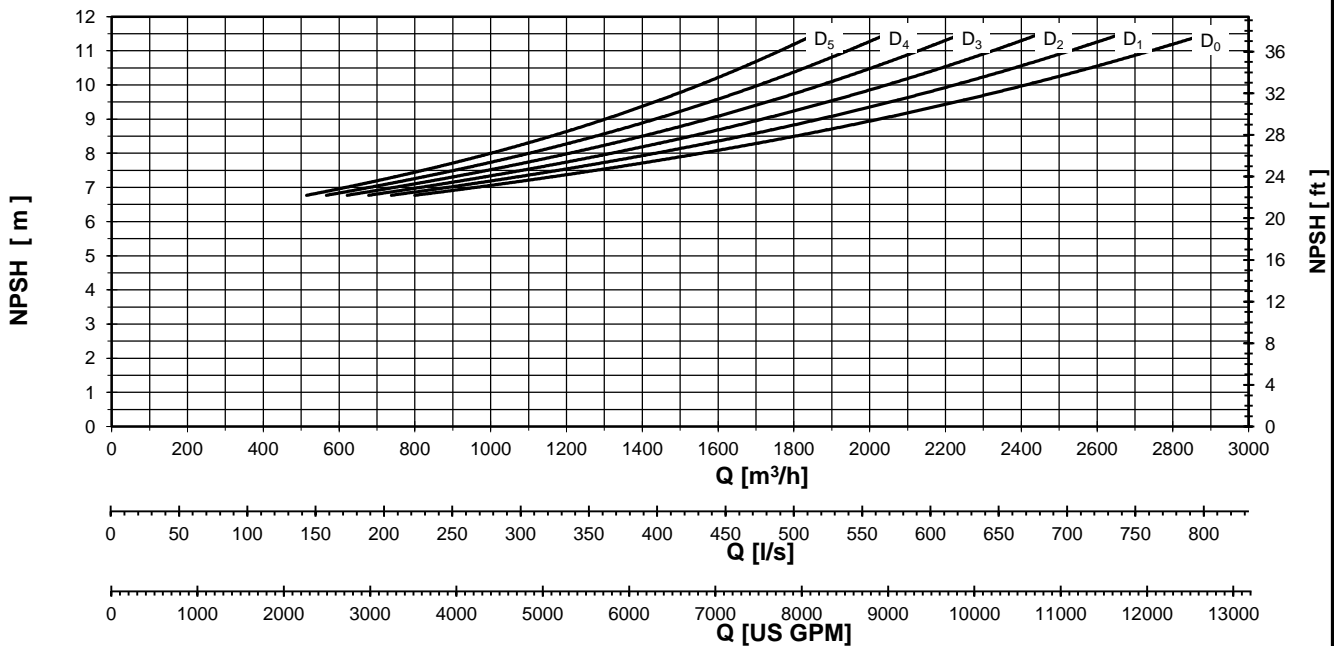
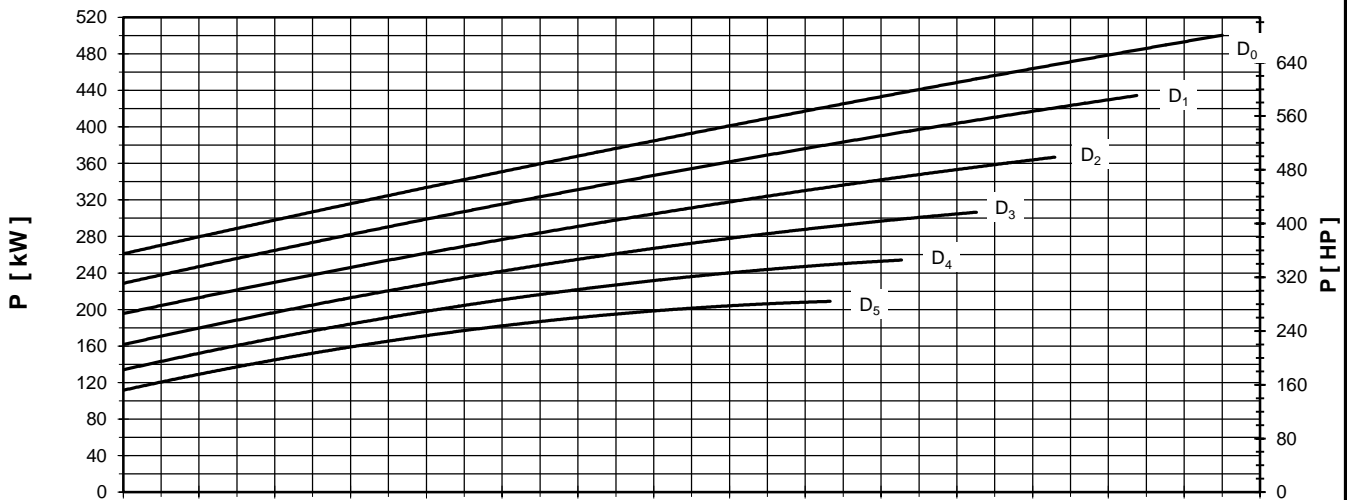
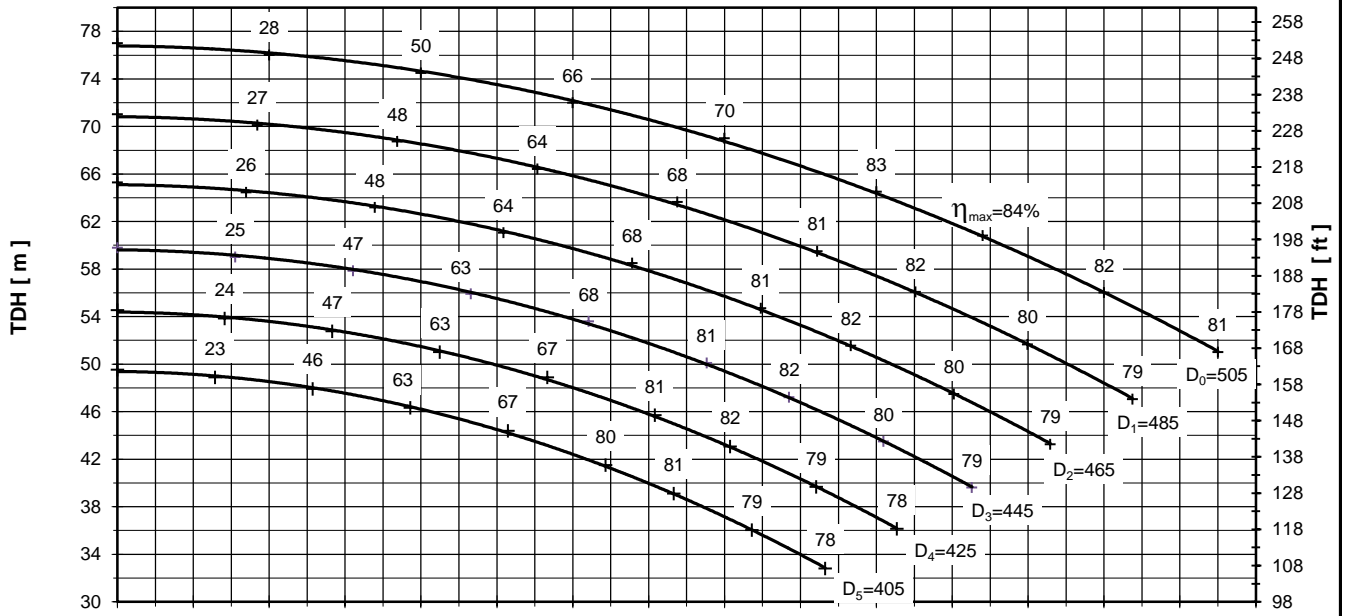

Performance curves are valid for clean cold water-kinematic viscosity 1 [mm²/s], density 1000 [kg/m³]. Methods and tolerances of presented performance curves are in accordance with ISO 9906 - Annex A



PUMP PERFORMANCE CURVES  
No. 4HD.0191.03

PUMP TYPE
SCP 350 - 650
1450 [rpm]

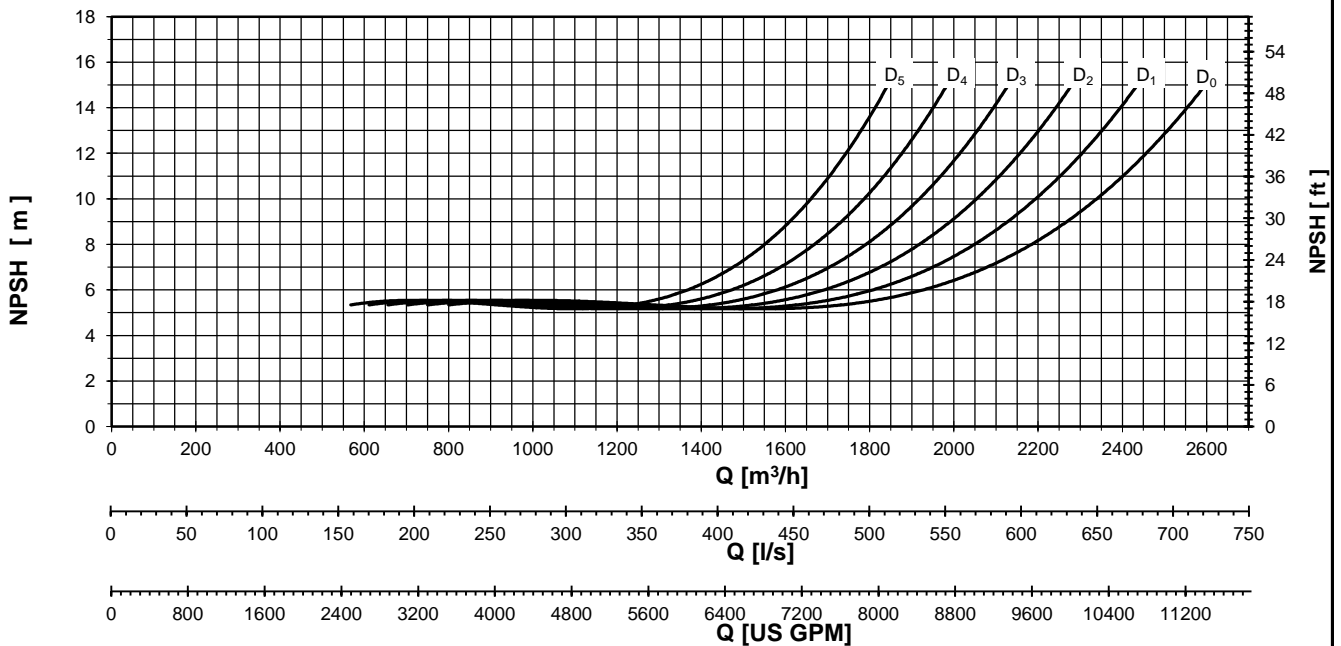
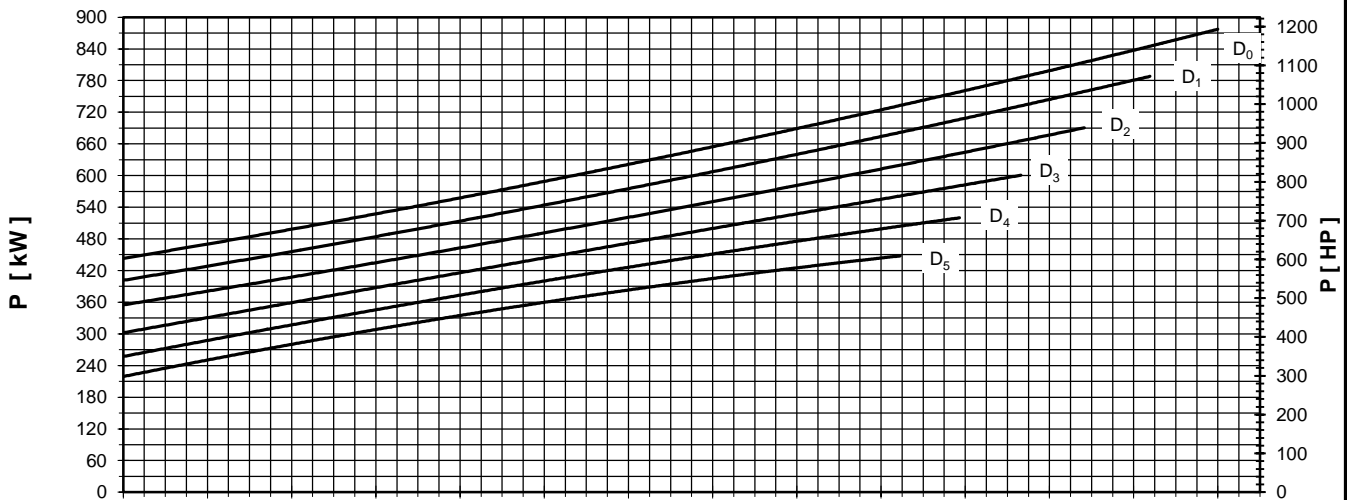
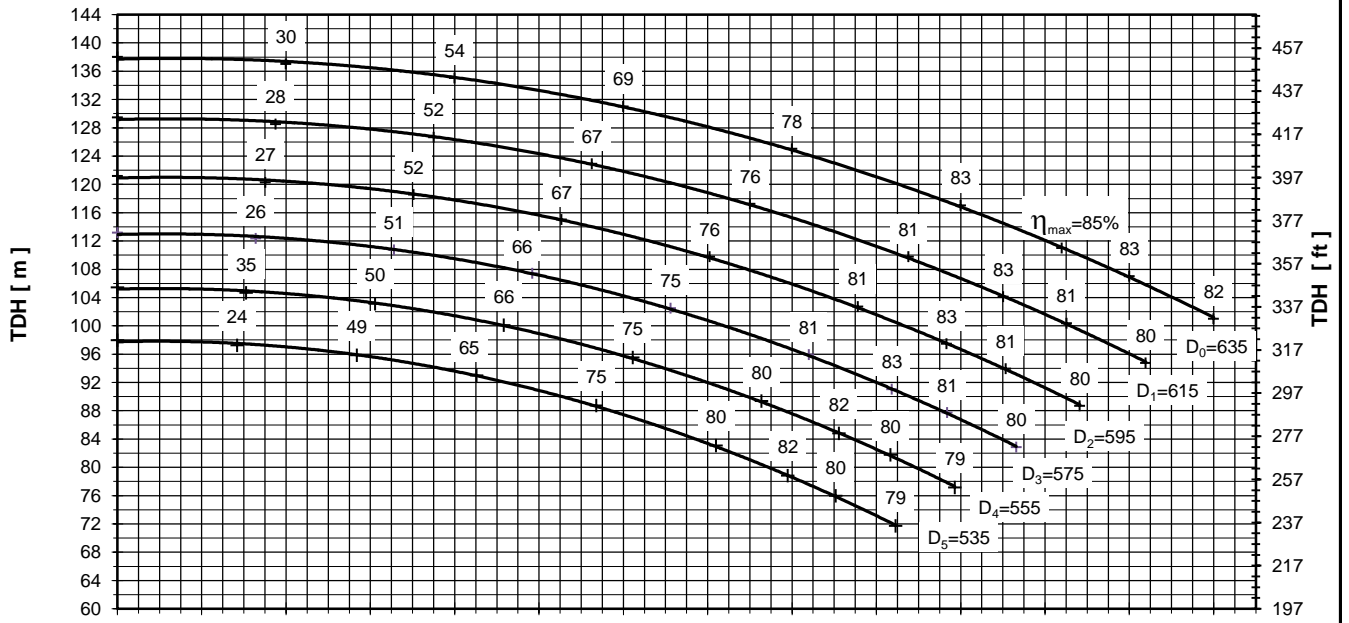

Performance curves are valid for clean cold water-kinematic viscosity 1 [mm²/s], density 1000 [kg/m³]. Methods and tolerances of presented performance curves are in accordance with ISO 9906 - Annex A



PUMP PERFORMANCE CURVES  
No. 4HD.0192.03

PUMP TYPE  
SCP 350 - 710  
1450 [rpm]

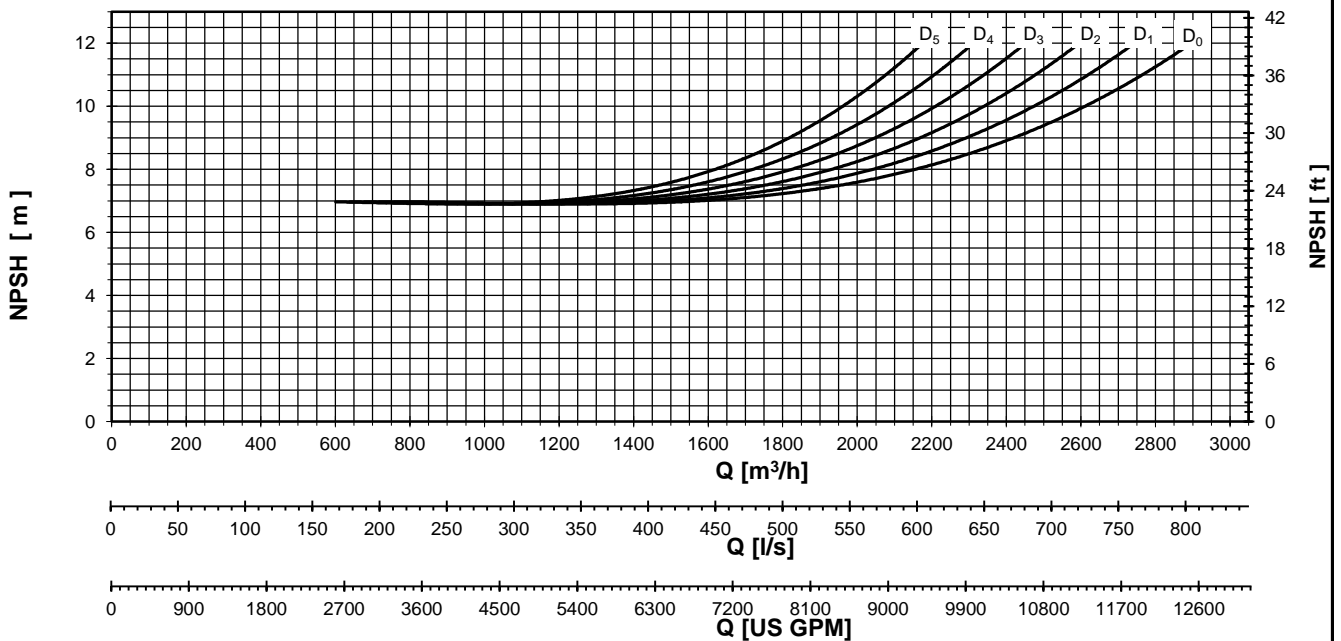
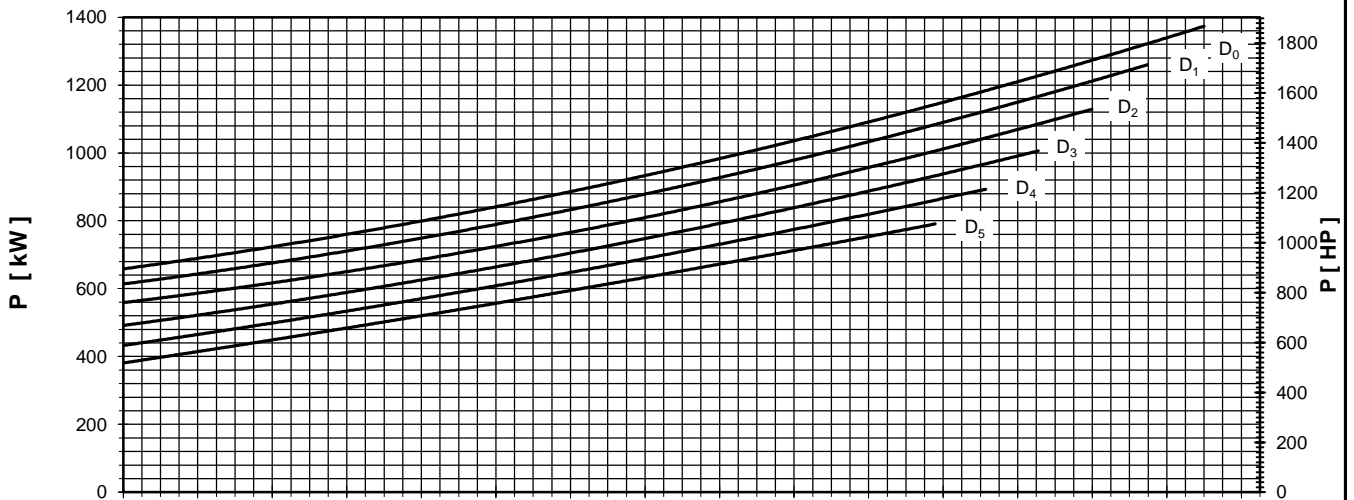
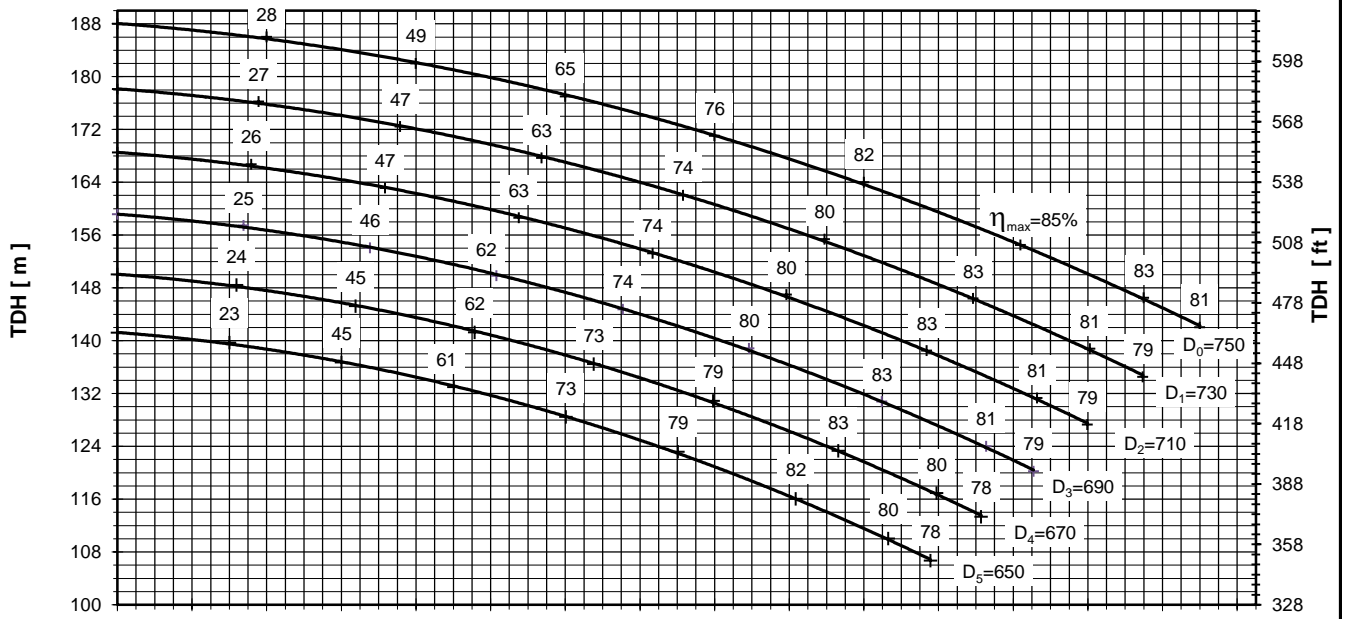

Performance curves are valid for clean cold water-kinematic viscosity 1 [mm<sup>2</sup>/s], density 1000 [kg/m<sup>3</sup>]. Methods and tolerances of presented performance curves are in accordance with ISO 9906 - Annex A

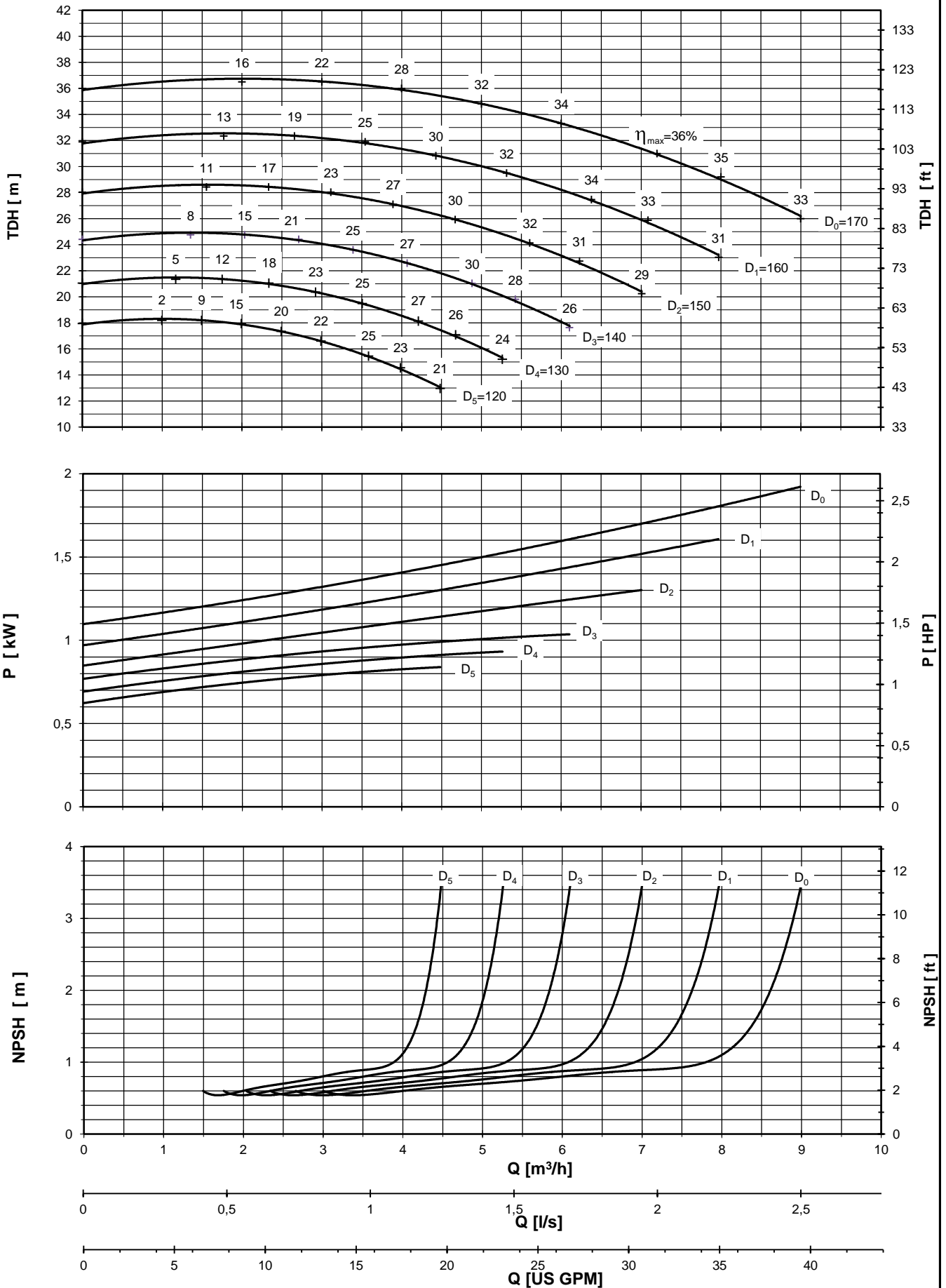

Performance curves are valid for clean cold water-kinematic viscosity 1 [mm<sup>2</sup>/s], density 1000 [kg/m<sup>3</sup>]. Methods and tolerances of presented performance curves are in accordance with ISO 9906 - Annex A





PUMP PERFORMANCE CURVES  
No. 4HD.0139.05

PUMP TYPE  
SCP 25 - 200  
2900 [rpm]

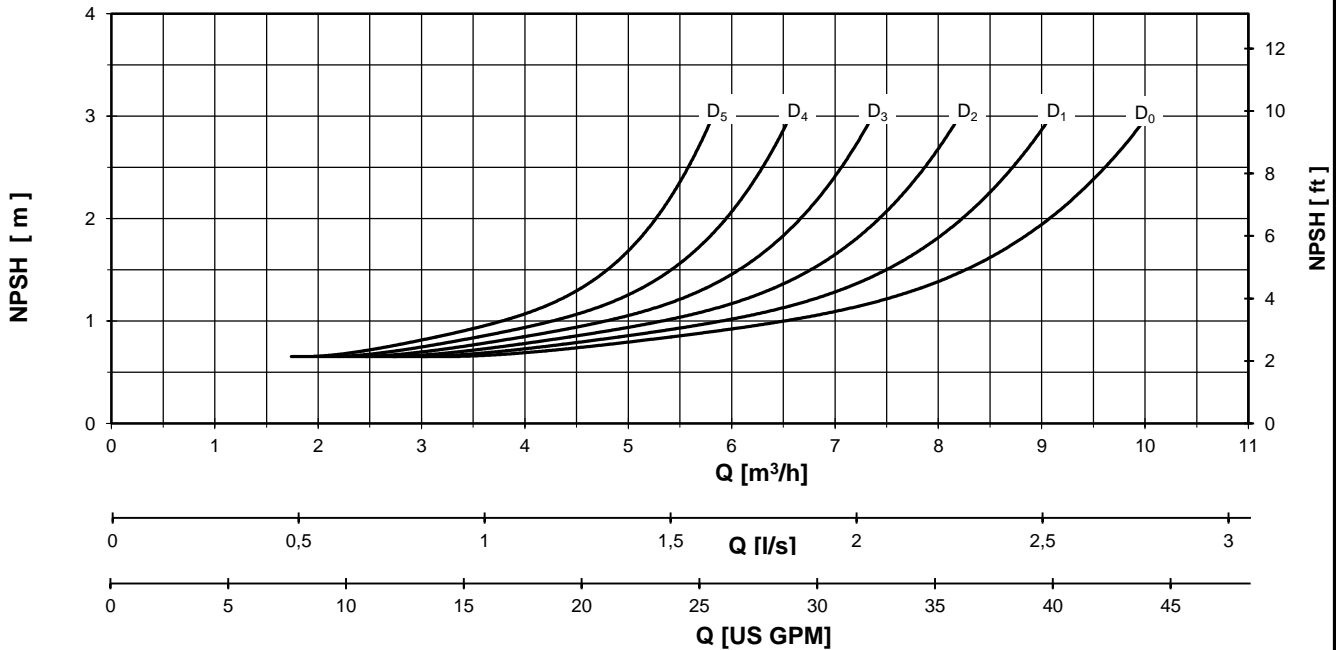
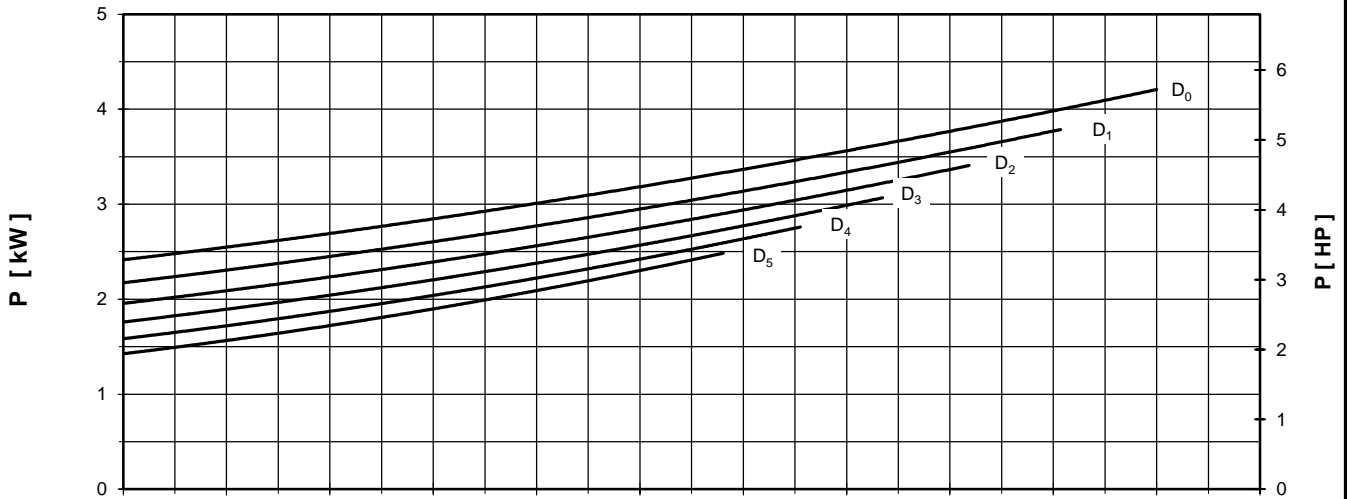
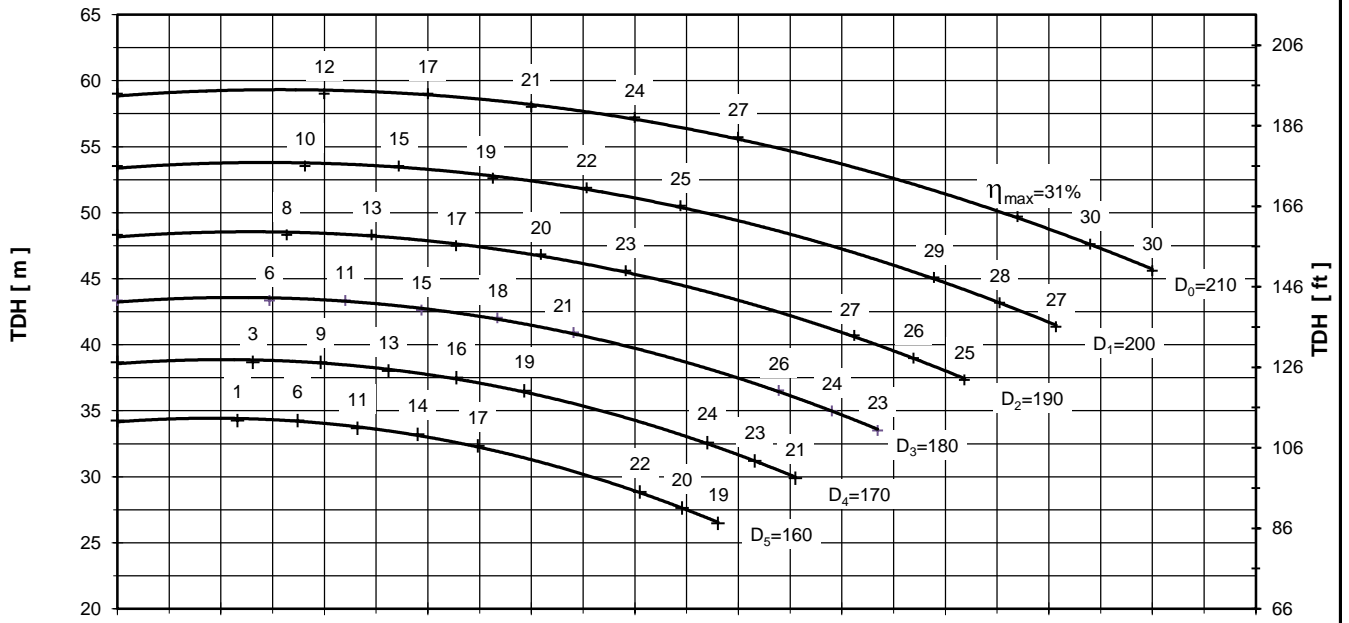

Performance curves are valid for clean cold water-kinematic viscosity 1 [mm²/s], density 1000 [kg/m³]. Methods and tolerances of presented performance curves are in accordance with ISO 9906 - Annex A

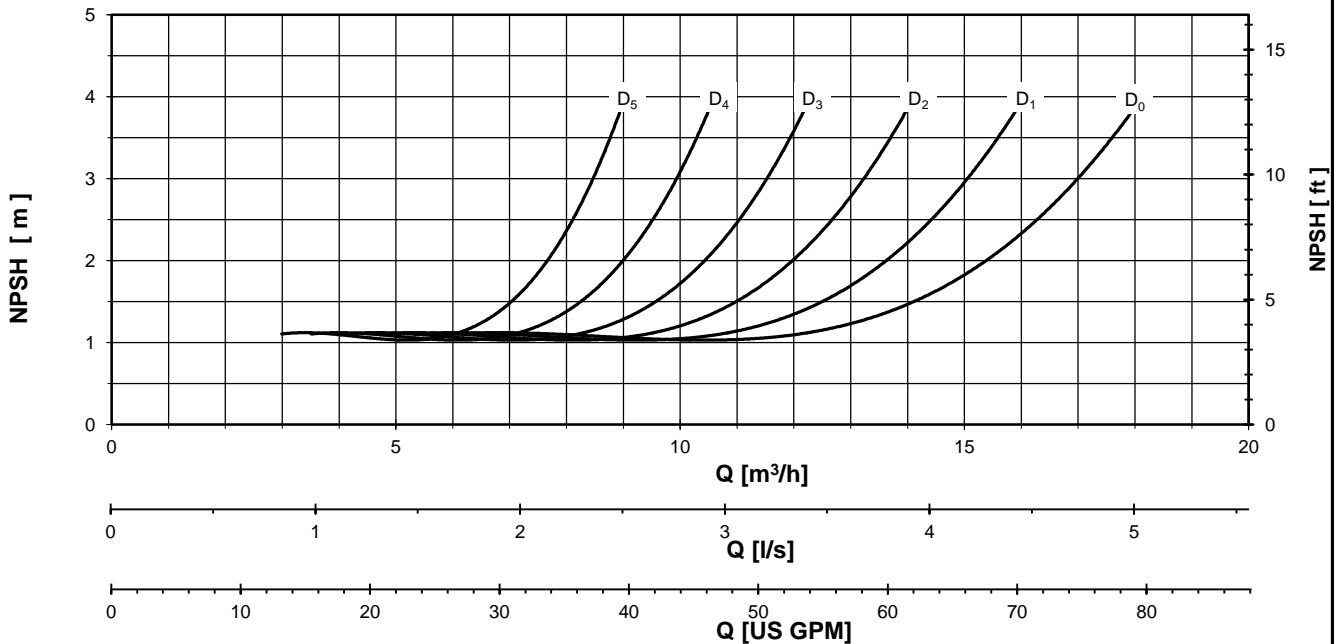
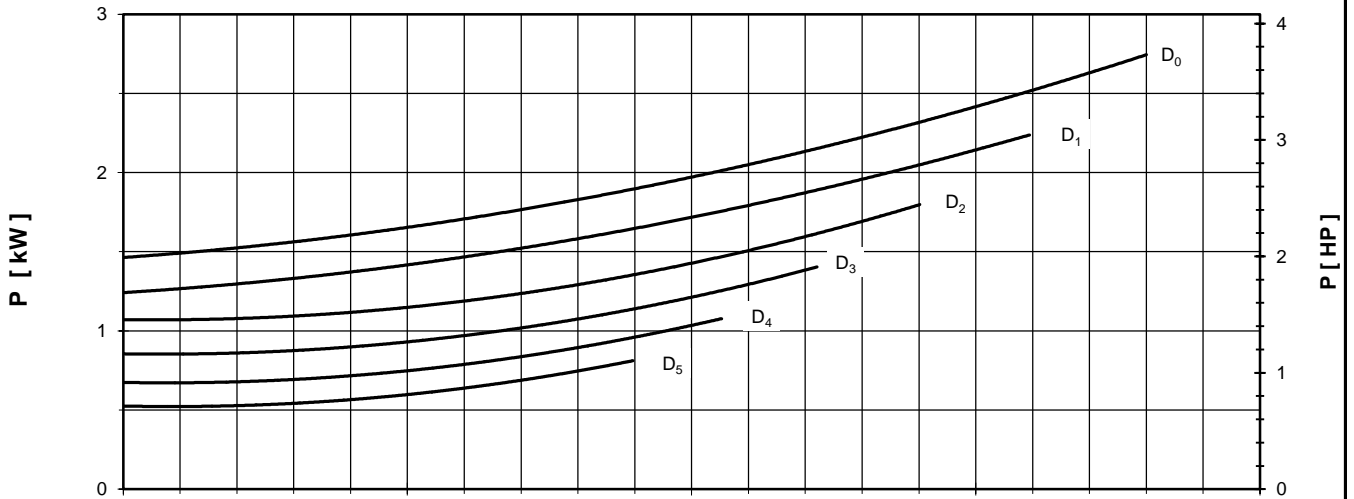
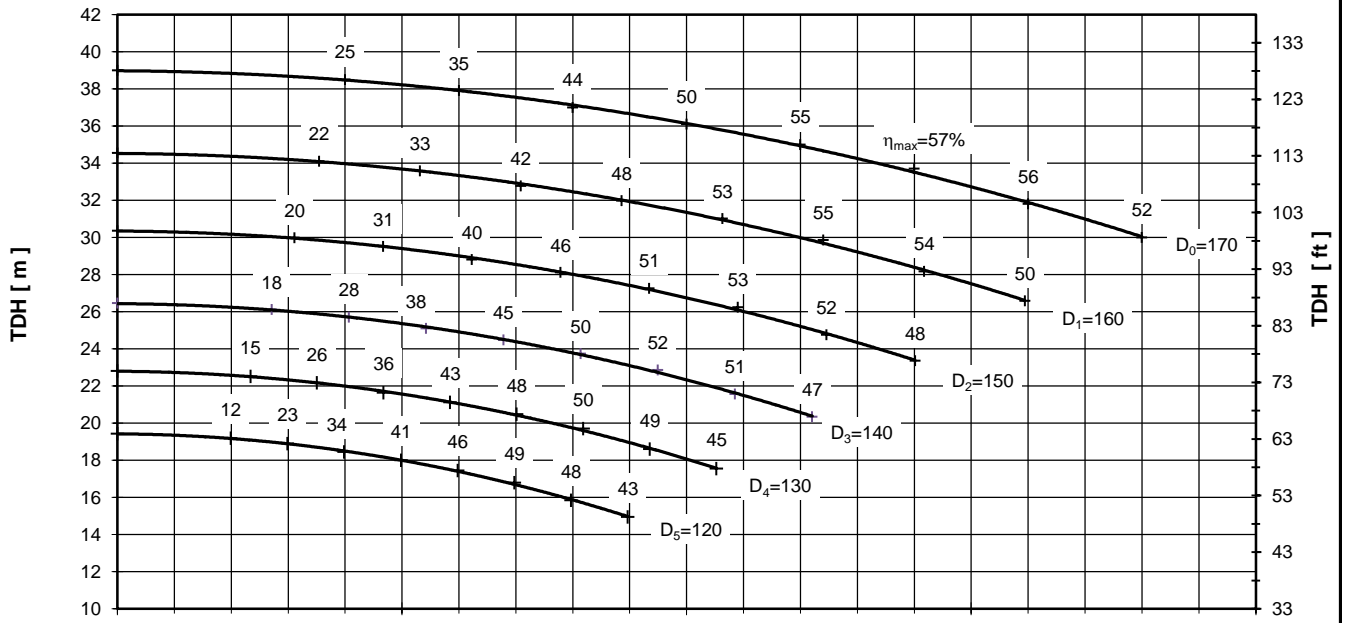

Performance curves are valid for clean cold water-kinematic viscosity 1 [mm<sup>2</sup>/s], density 1000 [kg/m<sup>3</sup>]. Methods and tolerances of presented performance curves are in accordance with ISO 9906 - Annex A



PUMP PERFORMANCE CURVES  
No. 4HD.0143.05

PUMP TYPE  
SCP 32 - 200  
2900 [rpm]

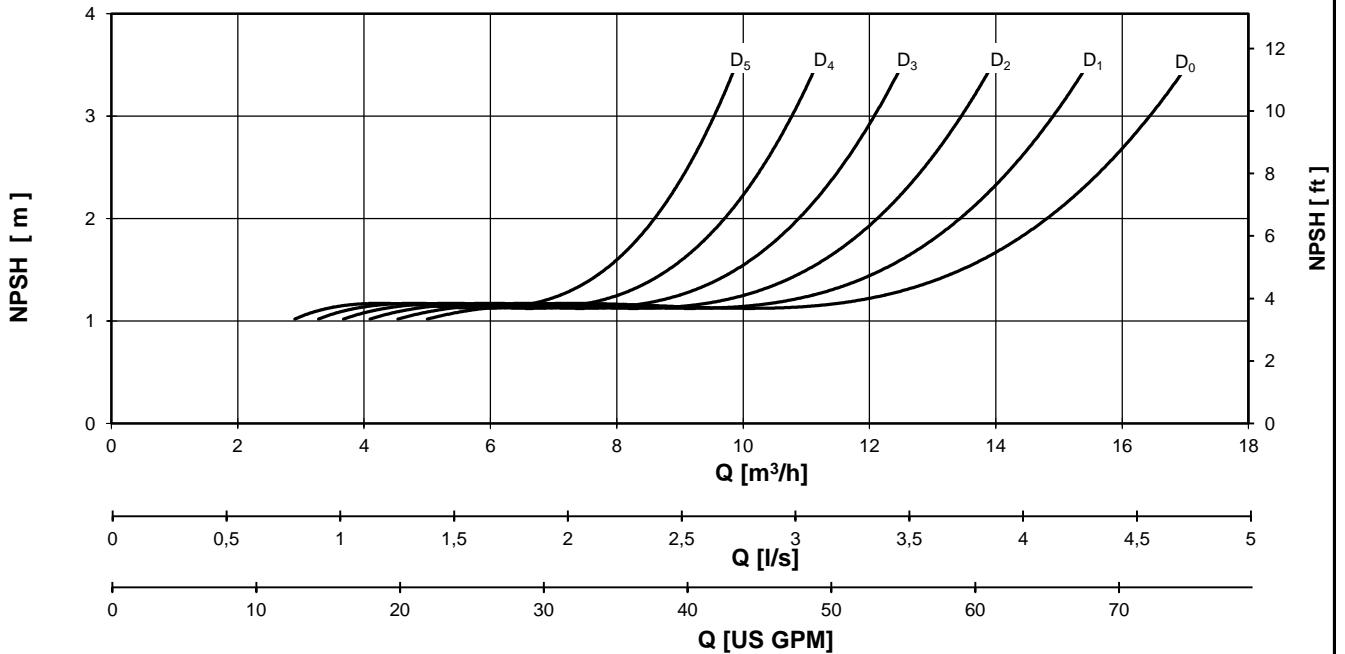
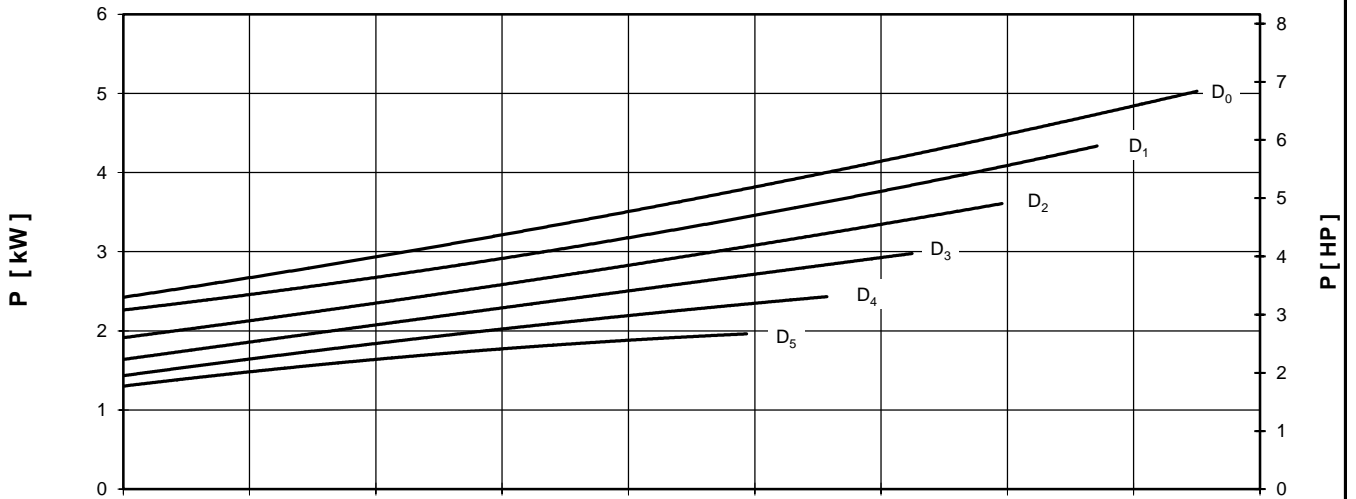
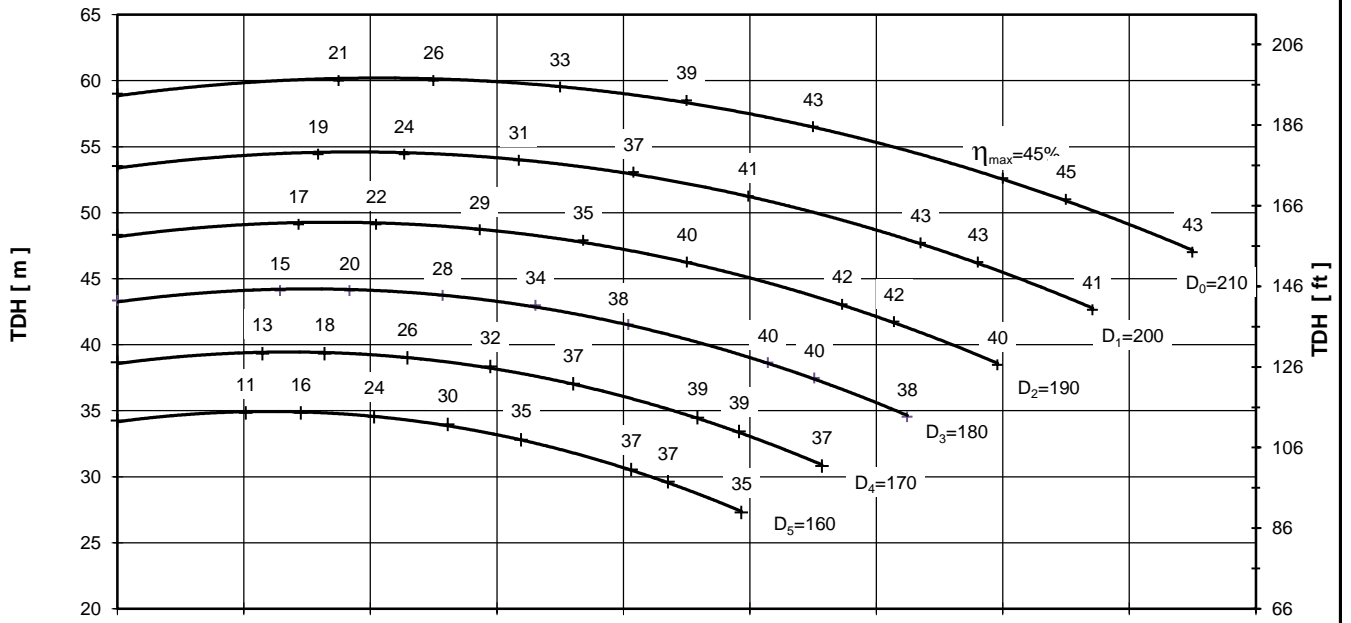

Performance curves are valid for clean cold water-kinematic viscosity 1 [mm<sup>2</sup>/s], density 1000 [kg/m<sup>3</sup>]. Methods and tolerances of presented performance curves are in accordance with ISO 9906 - Annex A



PUMP PERFORMANCE CURVES  
No. 4HS.0144.05

PUMP TYPE  
SCP 32 - 250  
2900 [rpm]

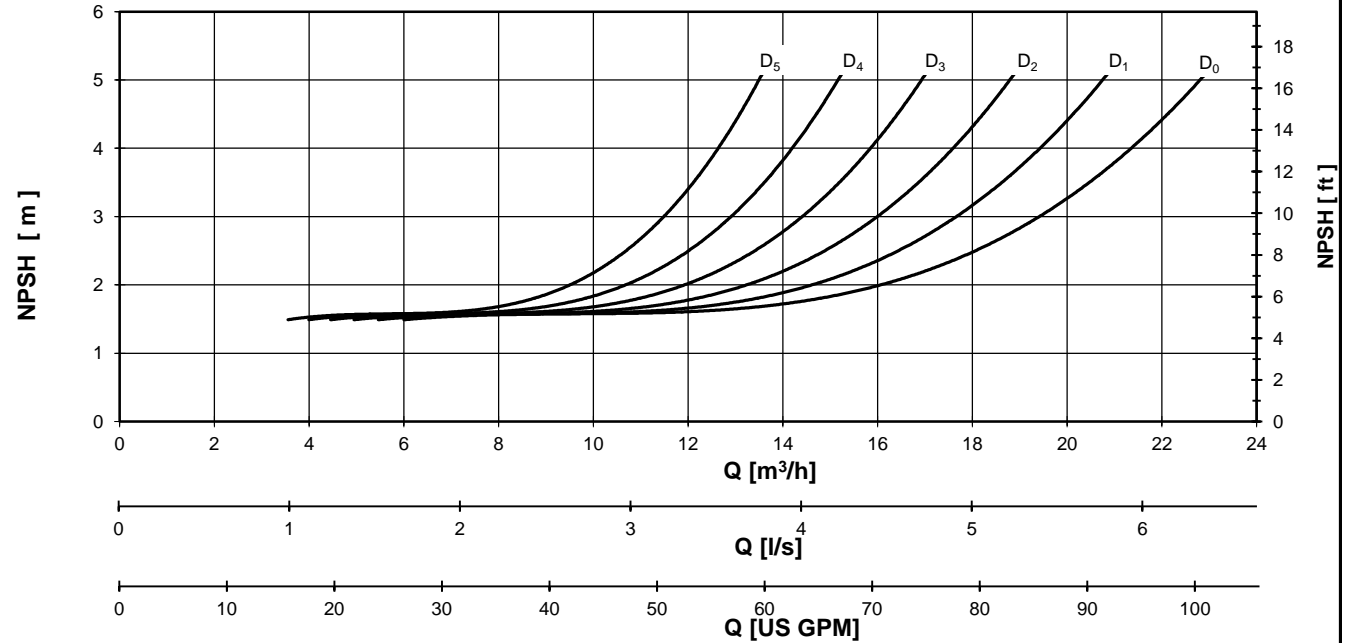
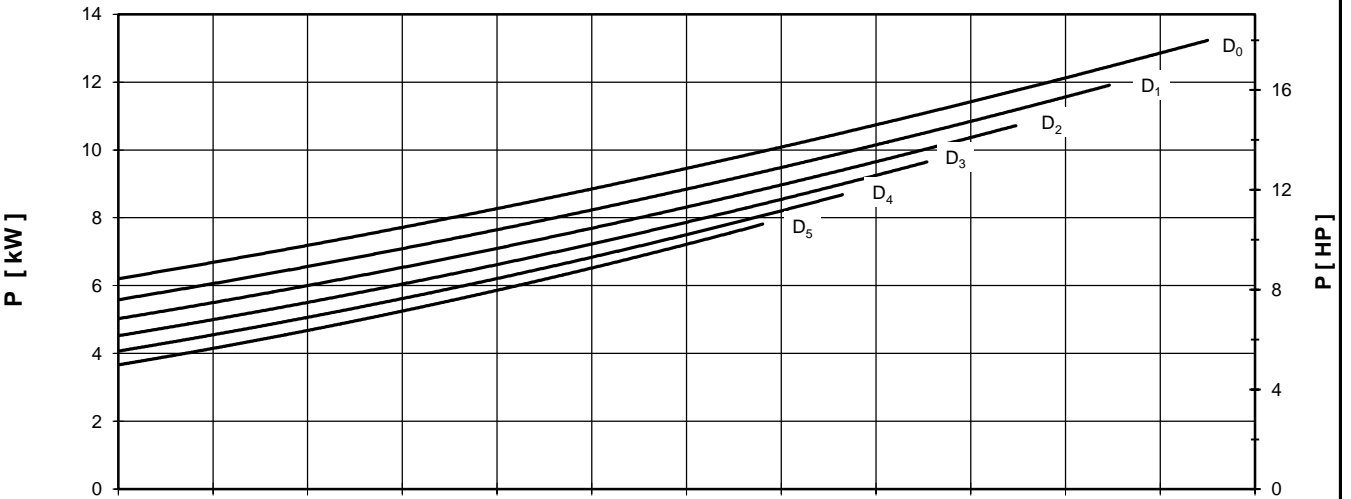
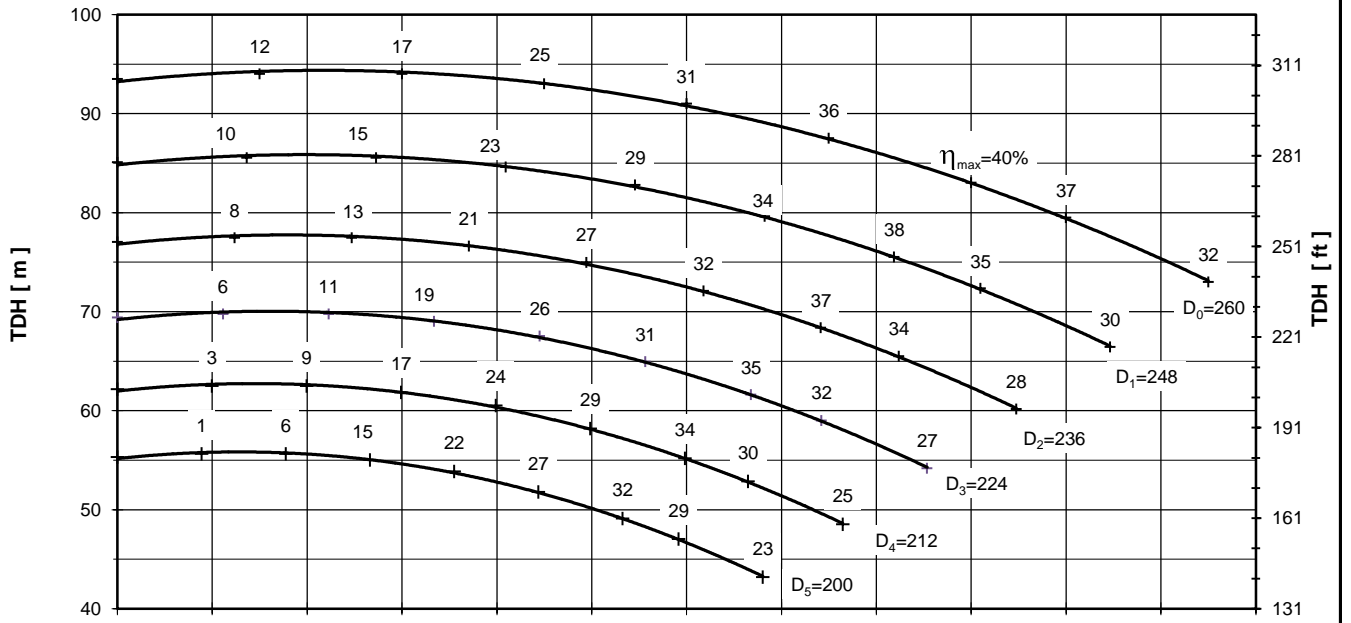

Performance curves are valid for clean cold water-kinematic viscosity 1 [mm<sup>2</sup>/s], density 1000 [kg/m<sup>3</sup>]. Methods and tolerances of presented performance curves are in accordance with ISO 9906 - Annex A

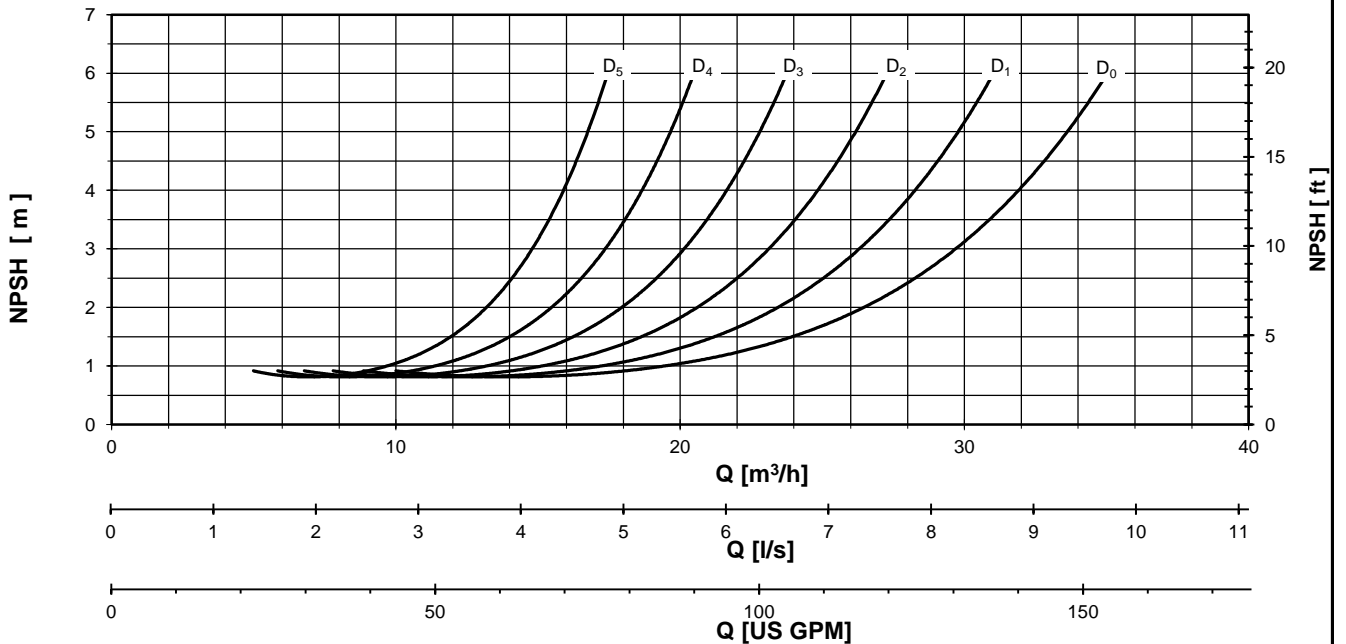
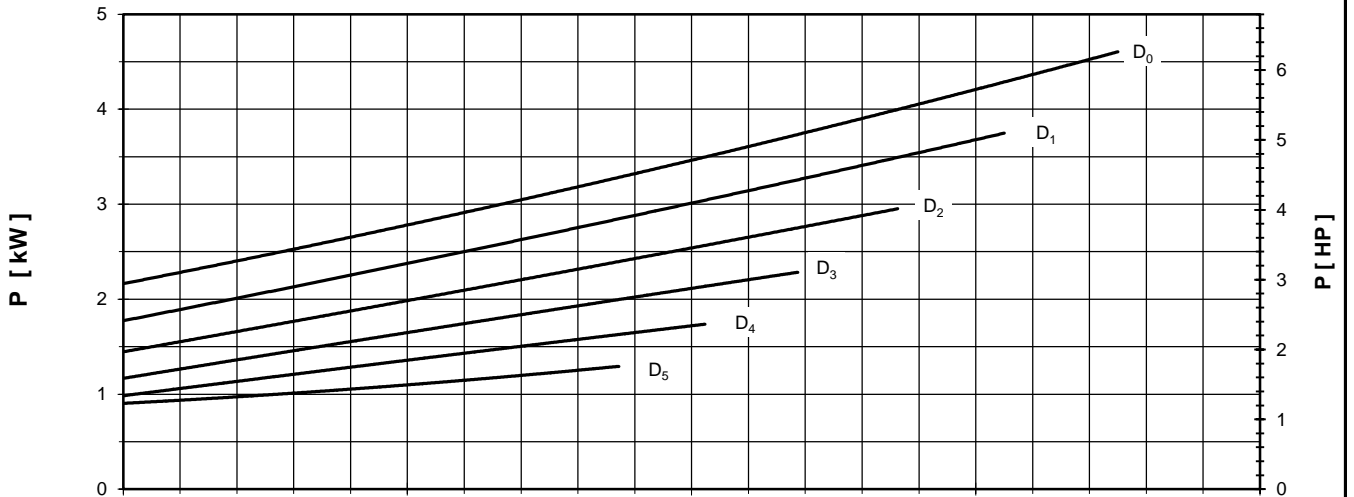
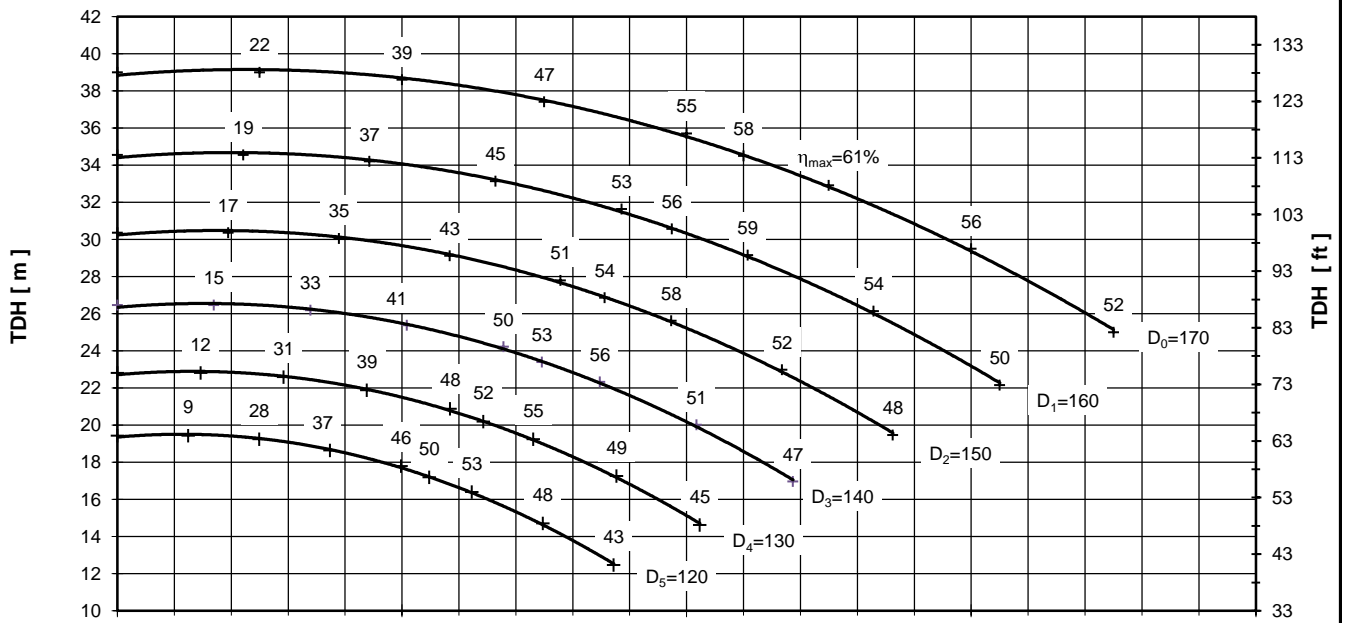



PUMP PERFORMANCE CURVES  
No. 4HD.0147.05

PUMP TYPE  
SCP 40 - 200  
2900 [rpm]

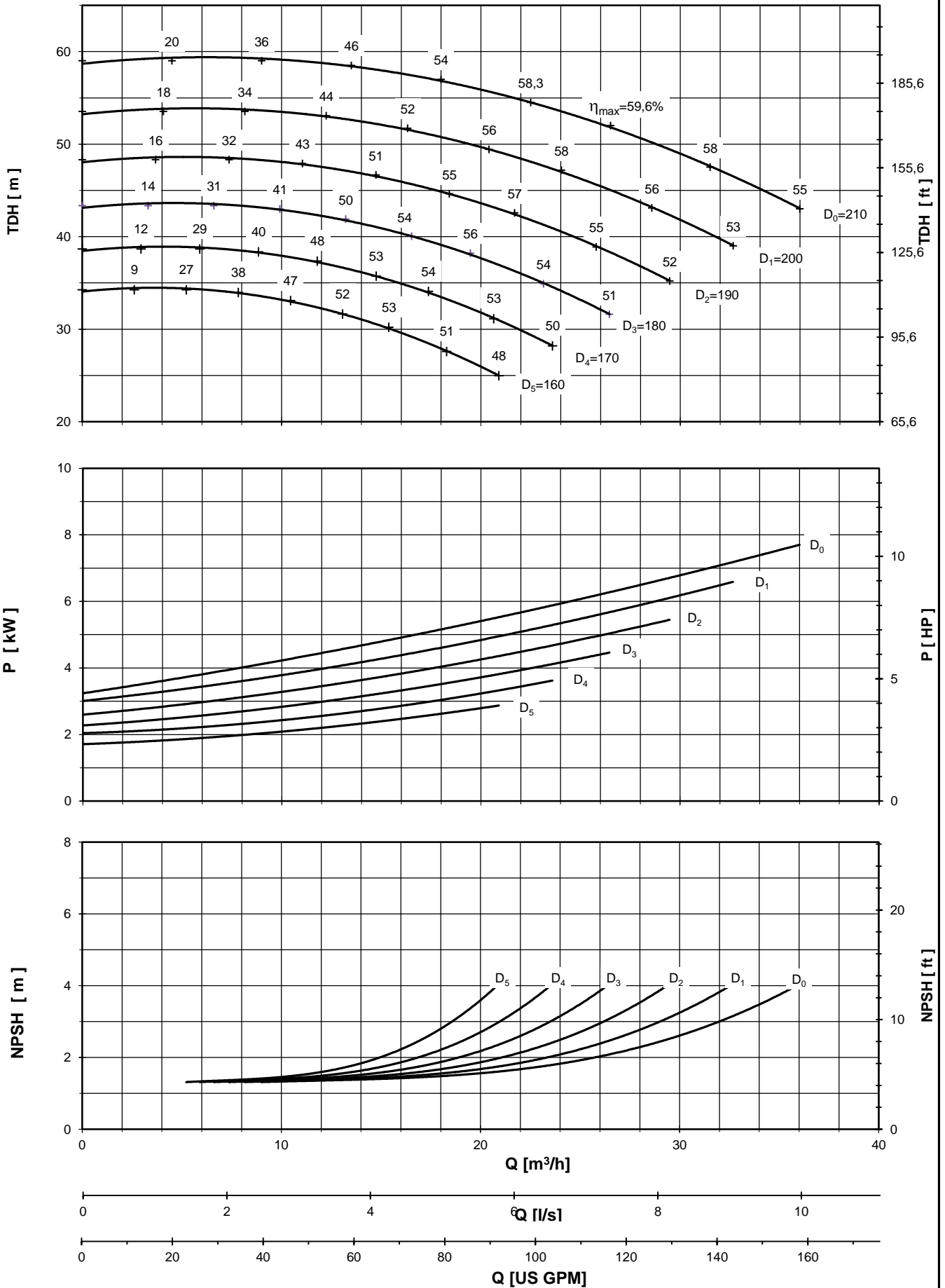

Performance curves are valid for clean cold water-kinematic viscosity 1 [mm²/s], density 1000 [kg/m³]. Methods and tolerances of presented performance curves are in accordance with ISO 9906 - Annex A

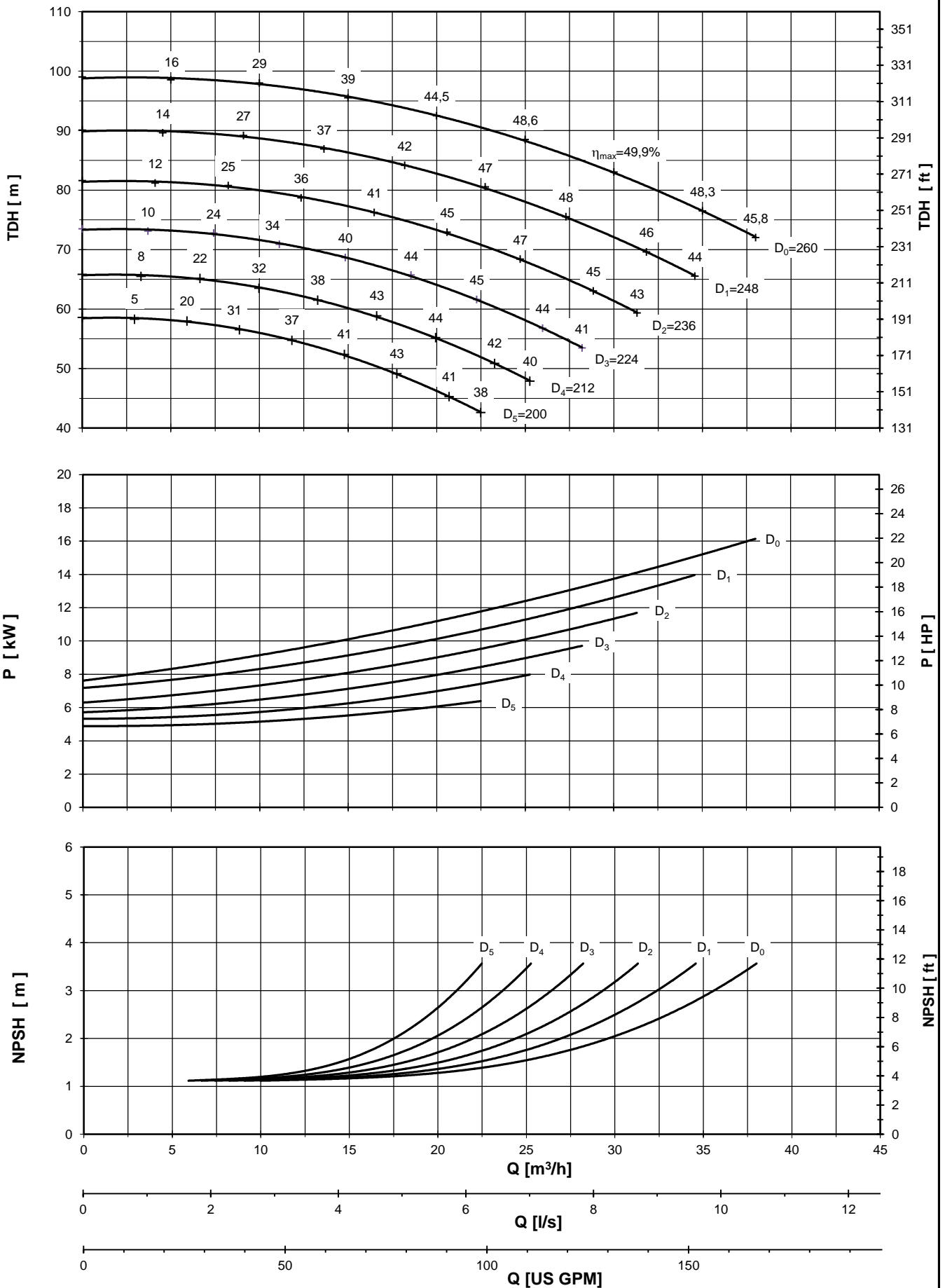

Performance curves are valid for clean cold water-kinematic viscosity 1 [mm²/s], density 1000 [kg/m³]. Methods and tolerances of presented performance curves are in accordance with ISO 9906 - Annex A

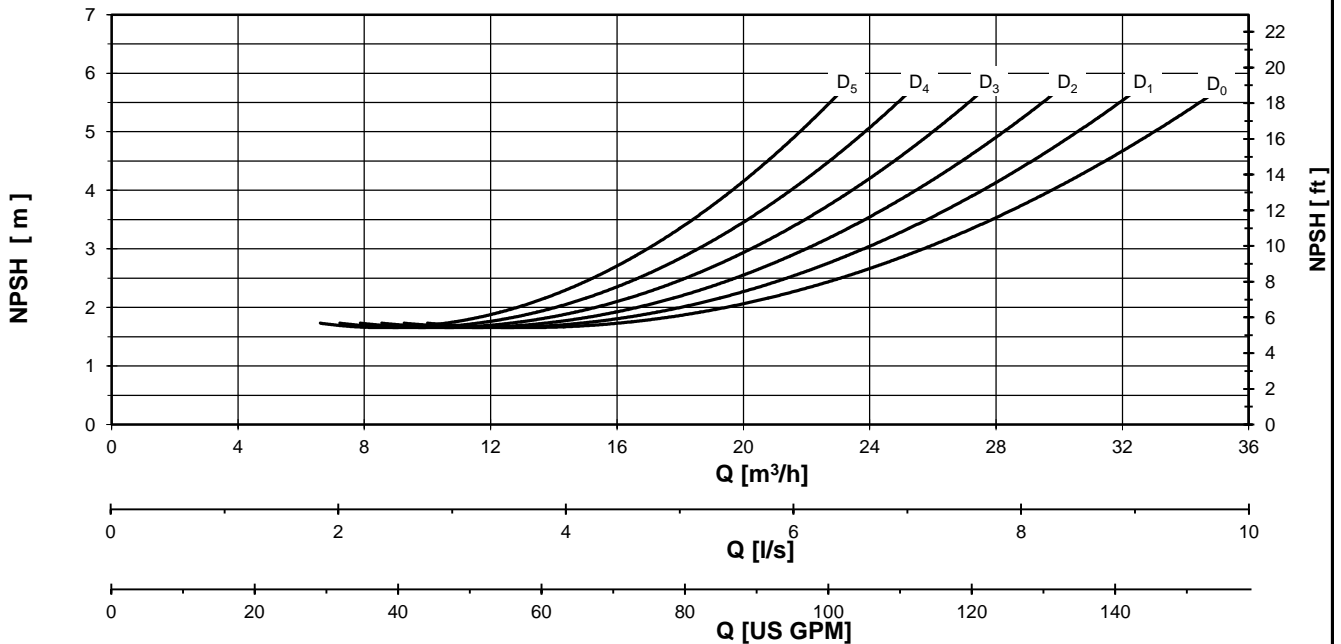
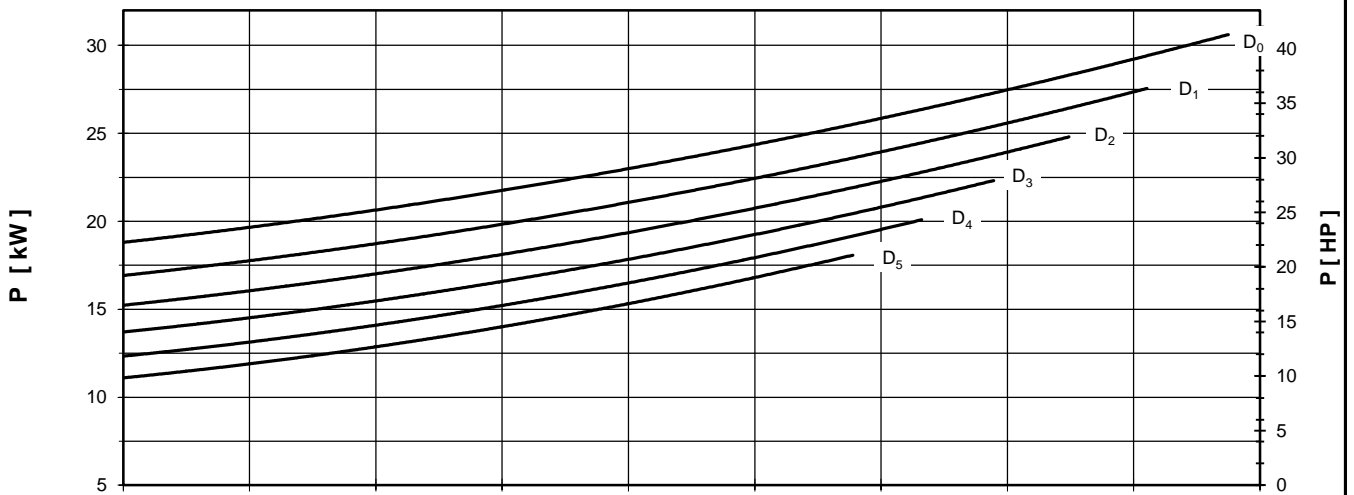
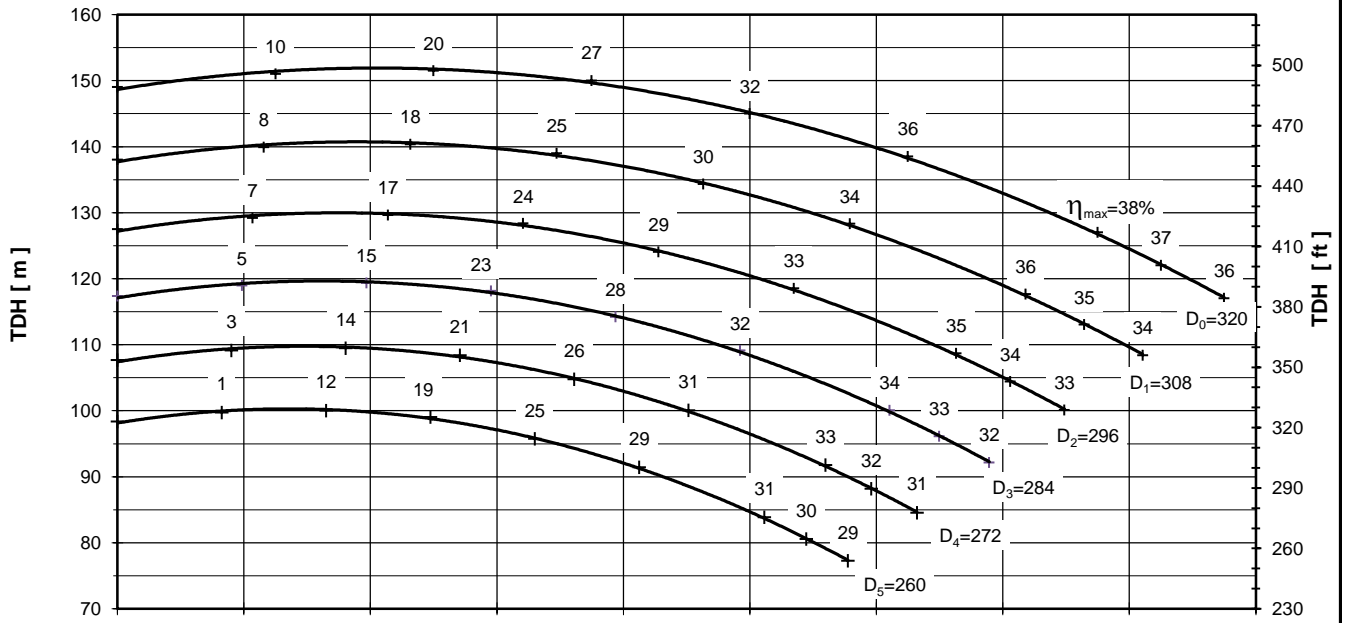



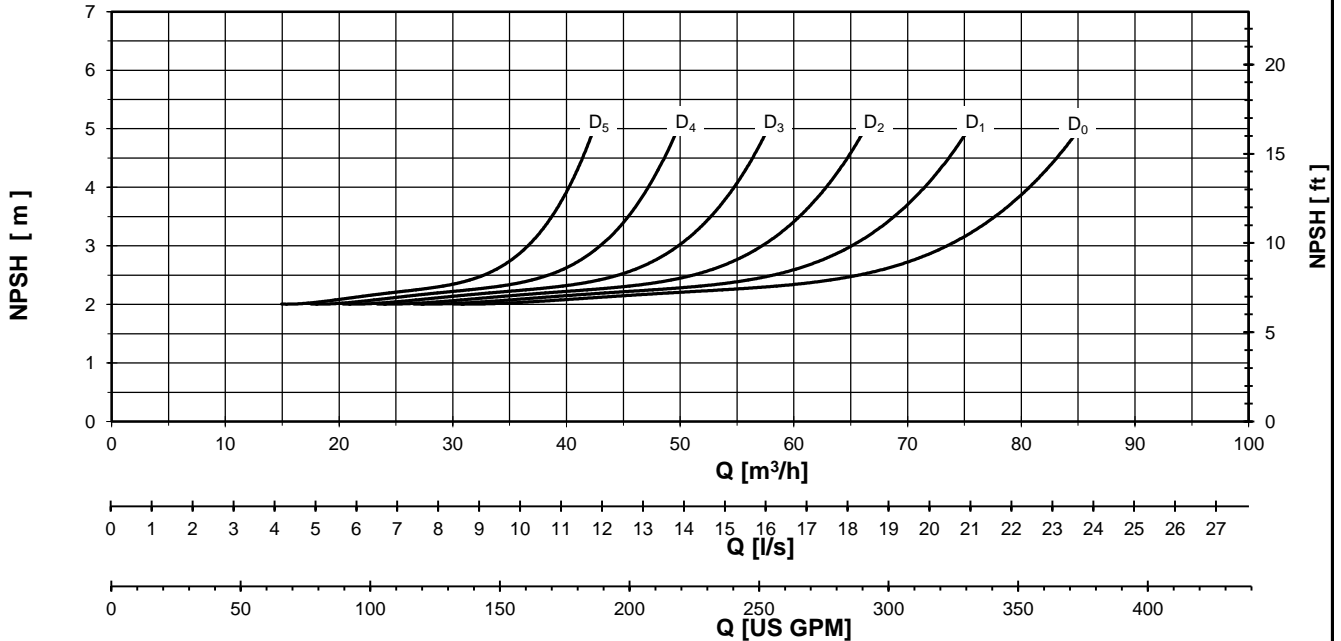
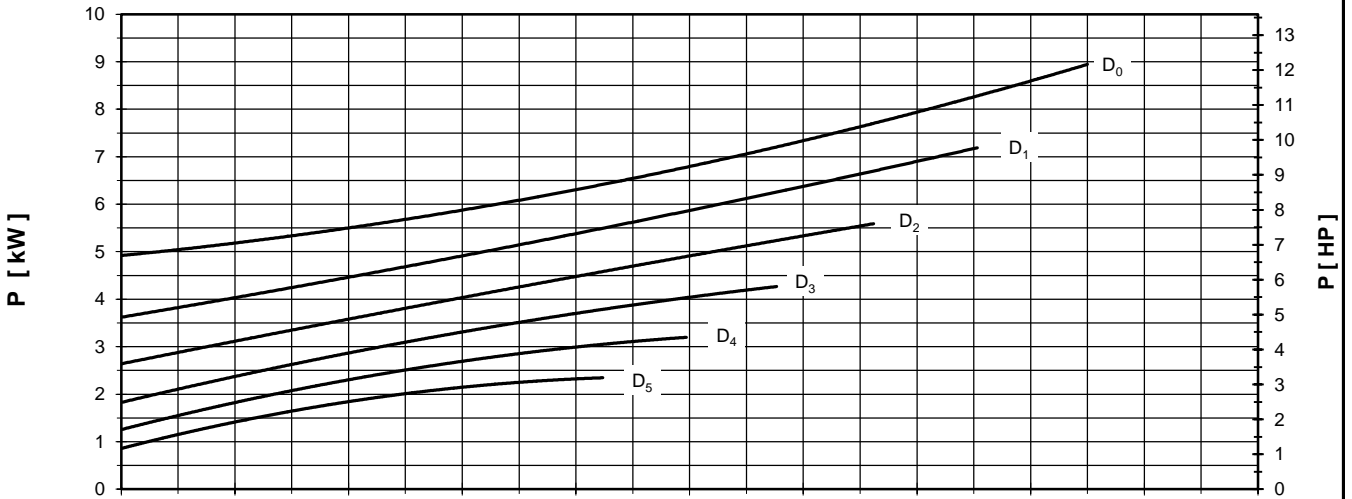
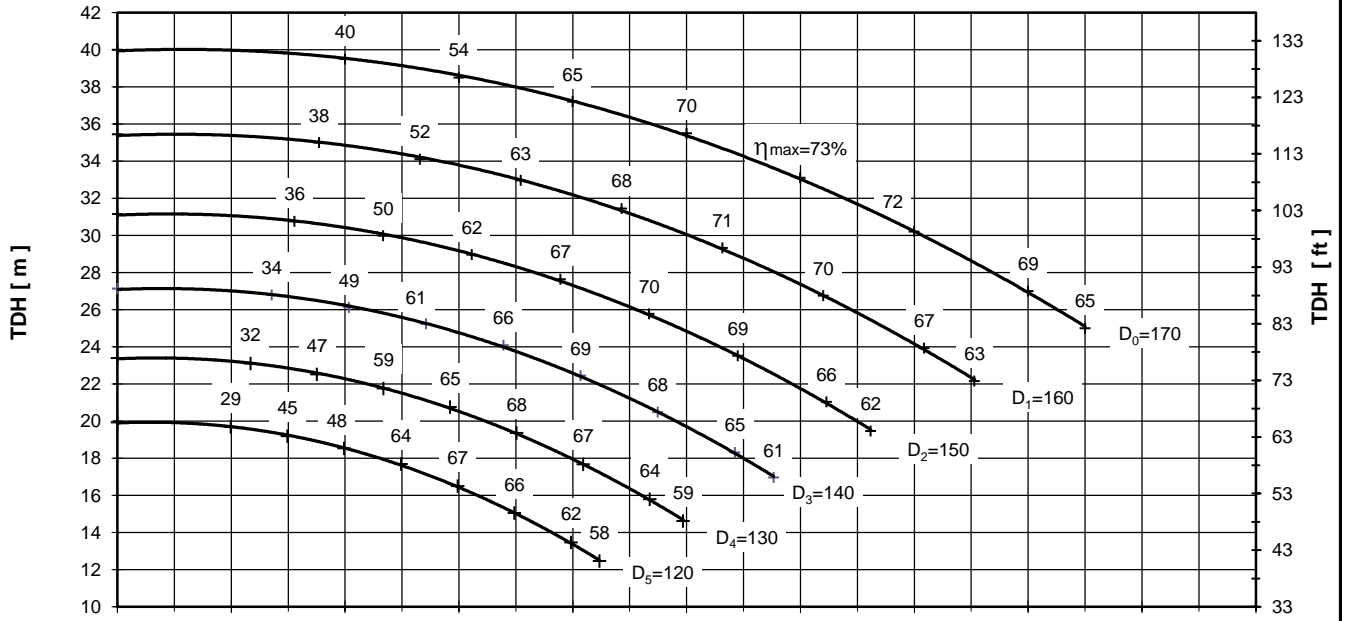

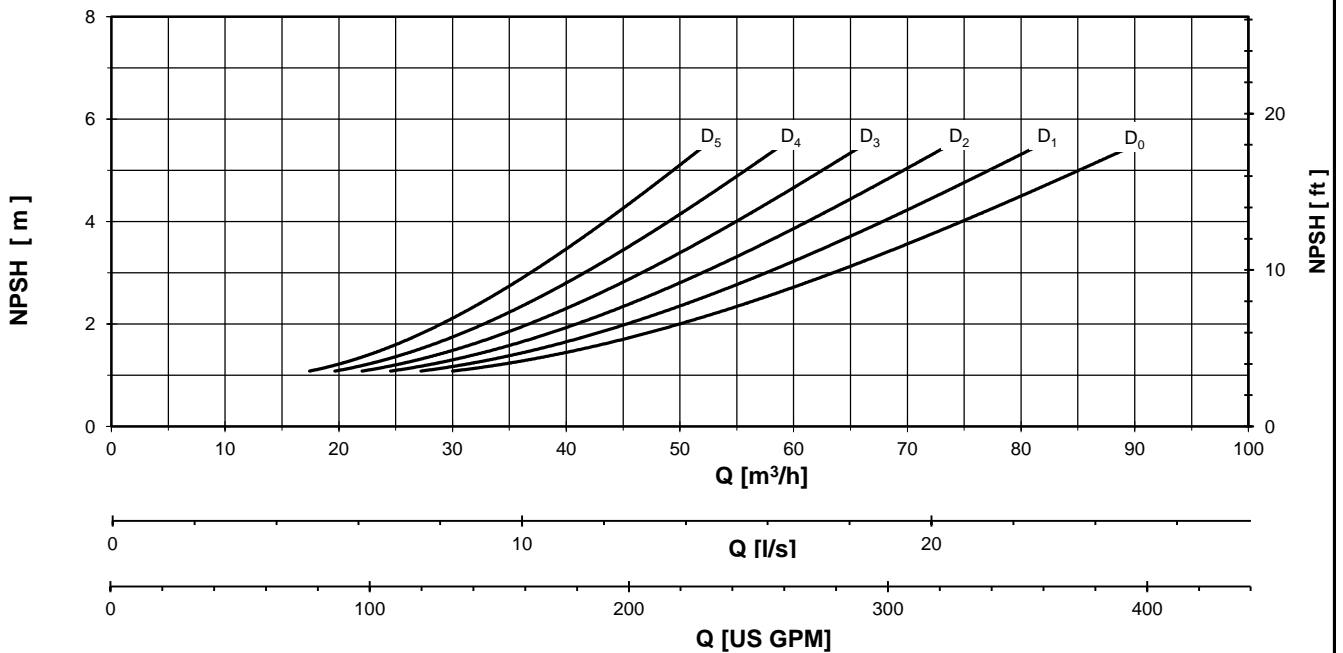
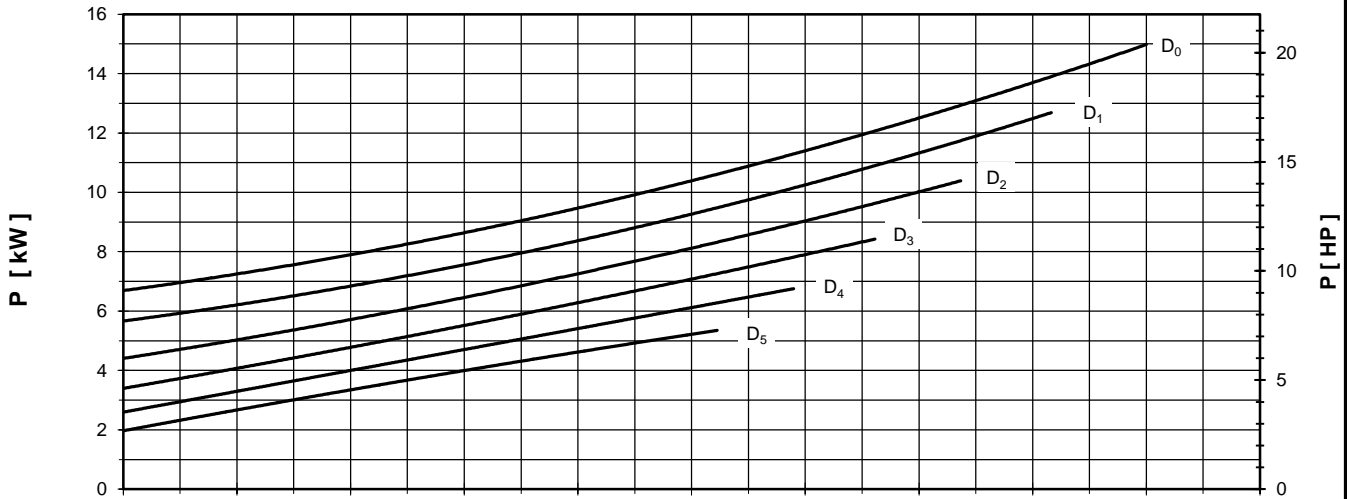
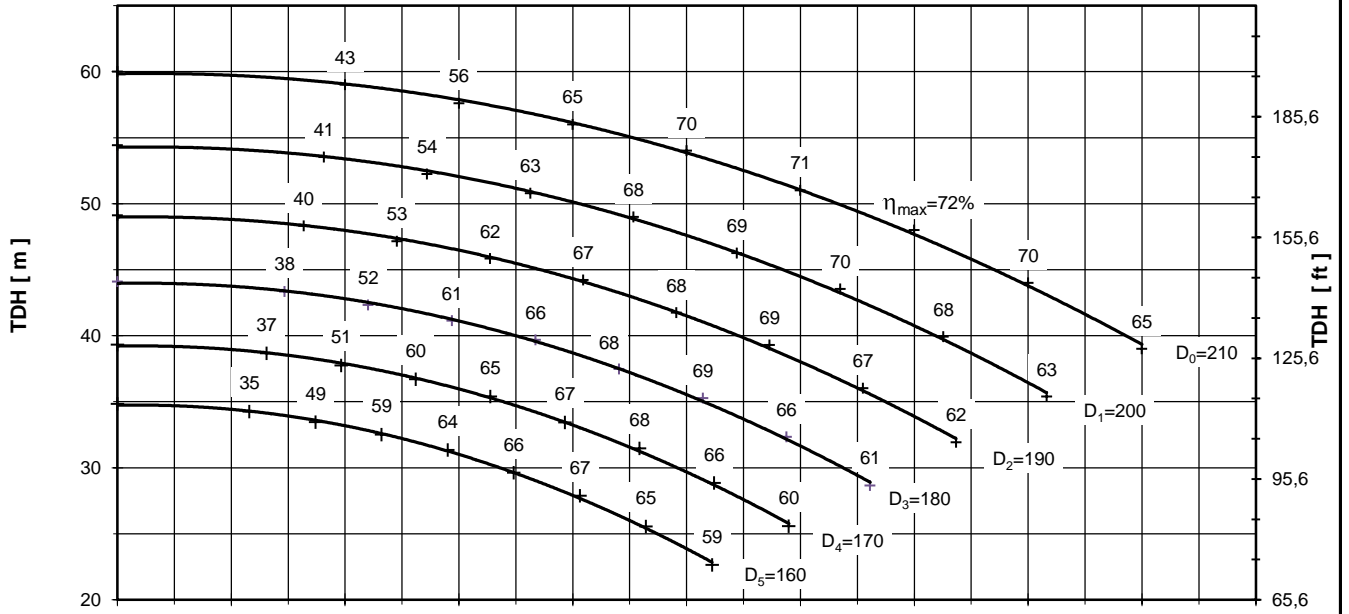

Performance curves are valid for clean cold water-kinematic viscosity 1 [mm<sup>2</sup>/s], density 1000 [kg/m<sup>3</sup>]. Methods and tolerances of presented performance curves are in accordance with ISO 9906 - Annex A



PUMP PERFORMANCE CURVES  
No. 4HS.0153.05

PUMP TYPE  
SCP 50 - 250  
2900 [rpm]

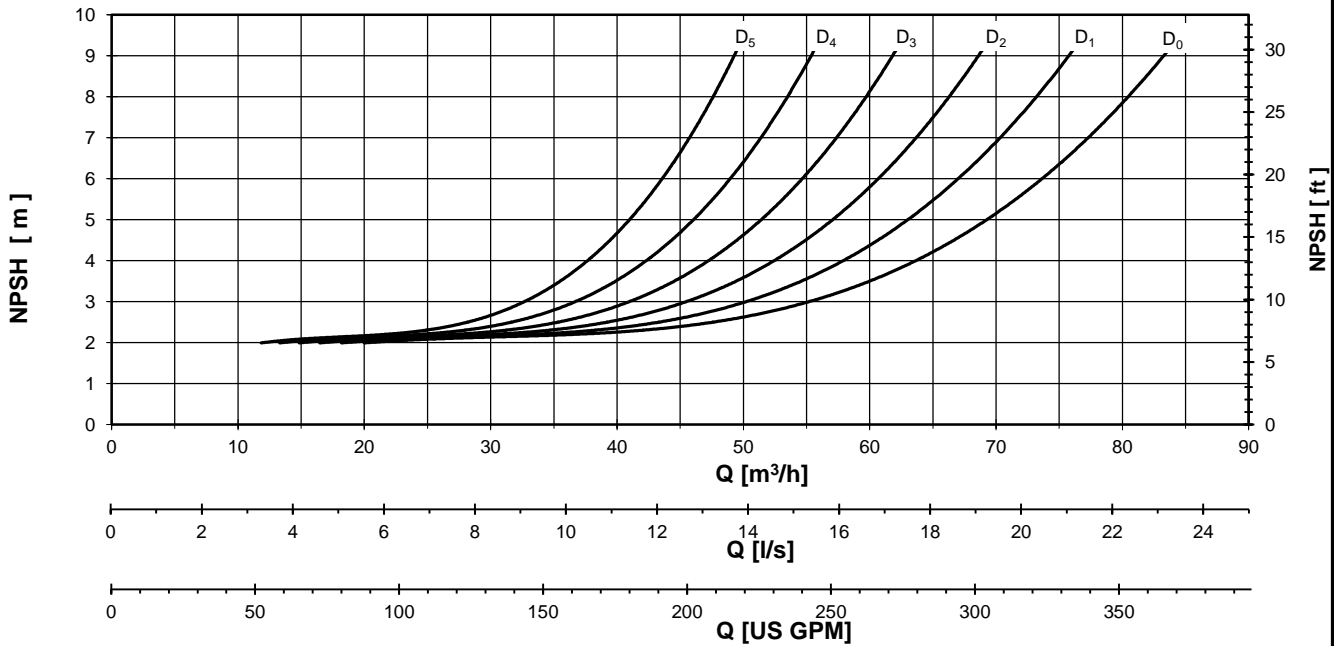
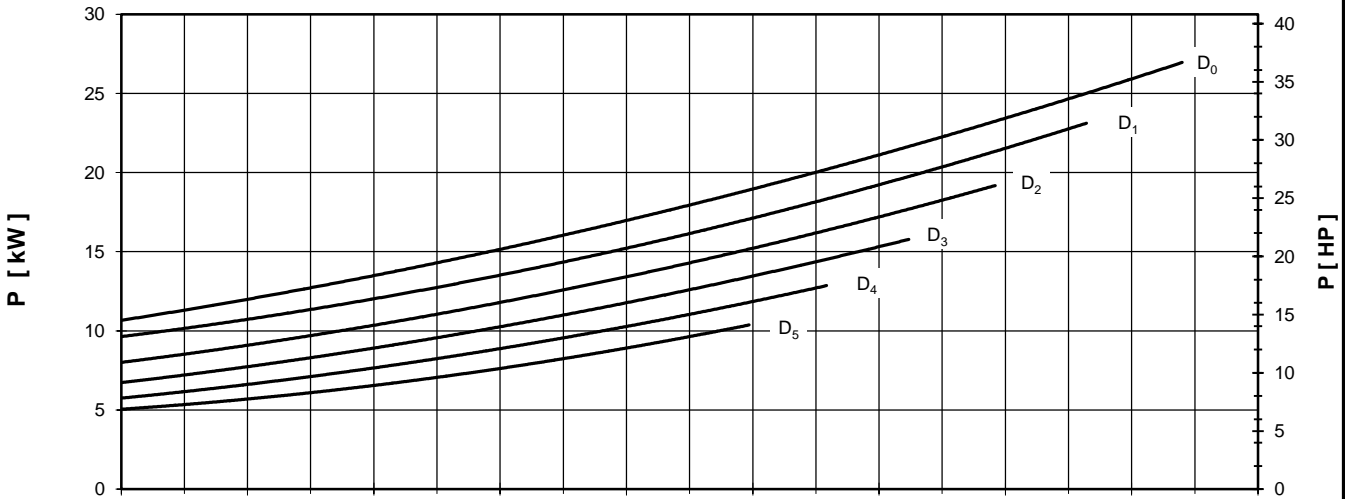
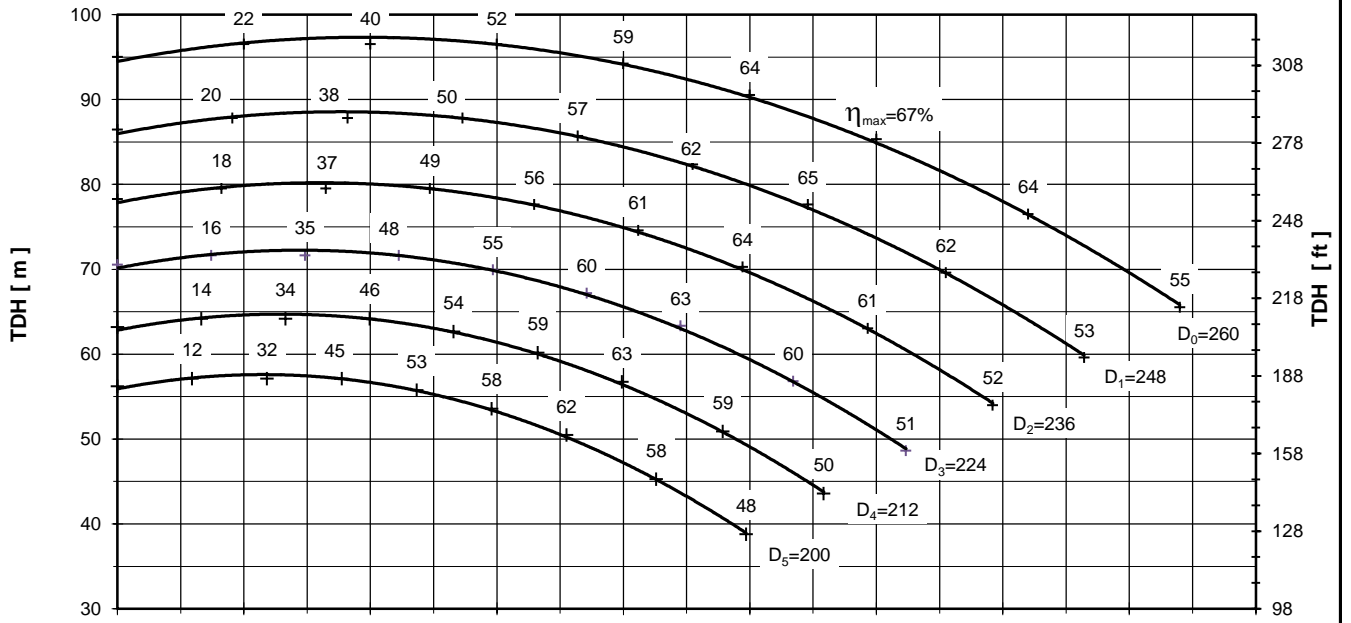

Performance curves are valid for clean cold water-kinematic viscosity 1 [mm²/s], density 1000 [kg/m³]. Methods and tolerances of presented performance curves are in accordance with ISO 9906 - Annex A



PUMP PERFORMANCE CURVES  
No. 4HD.0154.05

PUMP TYPE  
SCP 50 - 315  
2900 [rpm]

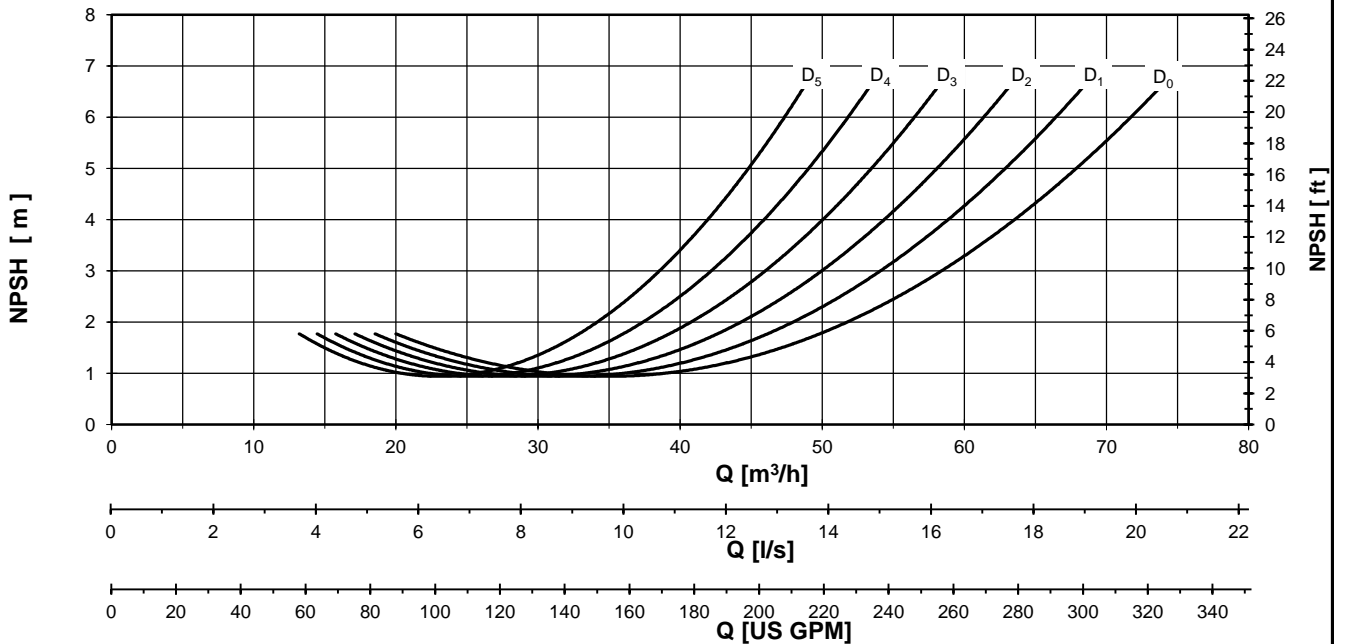
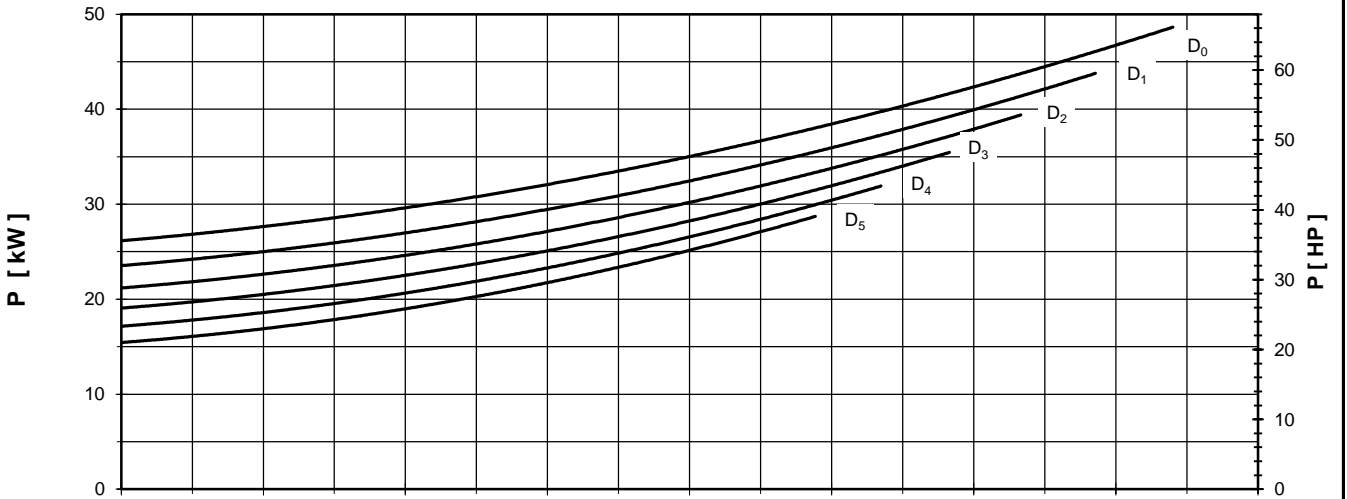
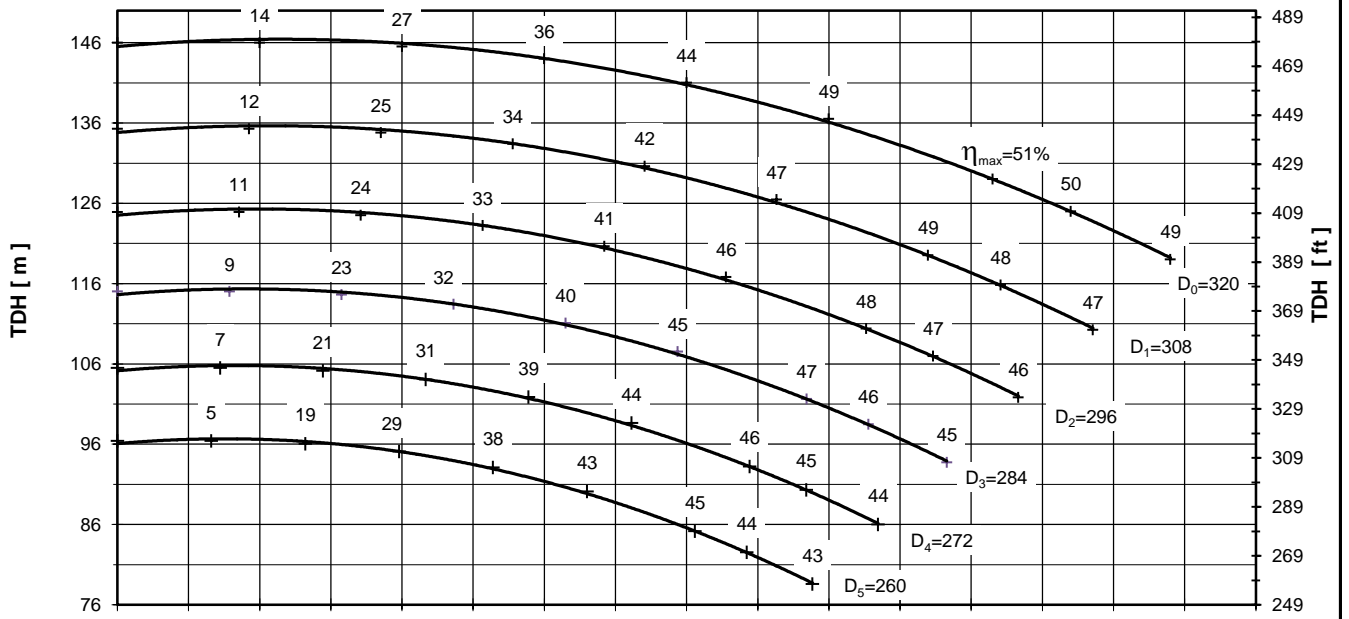

Performance curves are valid for clean cold water-kinematic viscosity 1 [mm²/s], density 1000 [kg/m³]. Methods and tolerances of presented performance curves are in accordance with ISO 9906 - Annex A

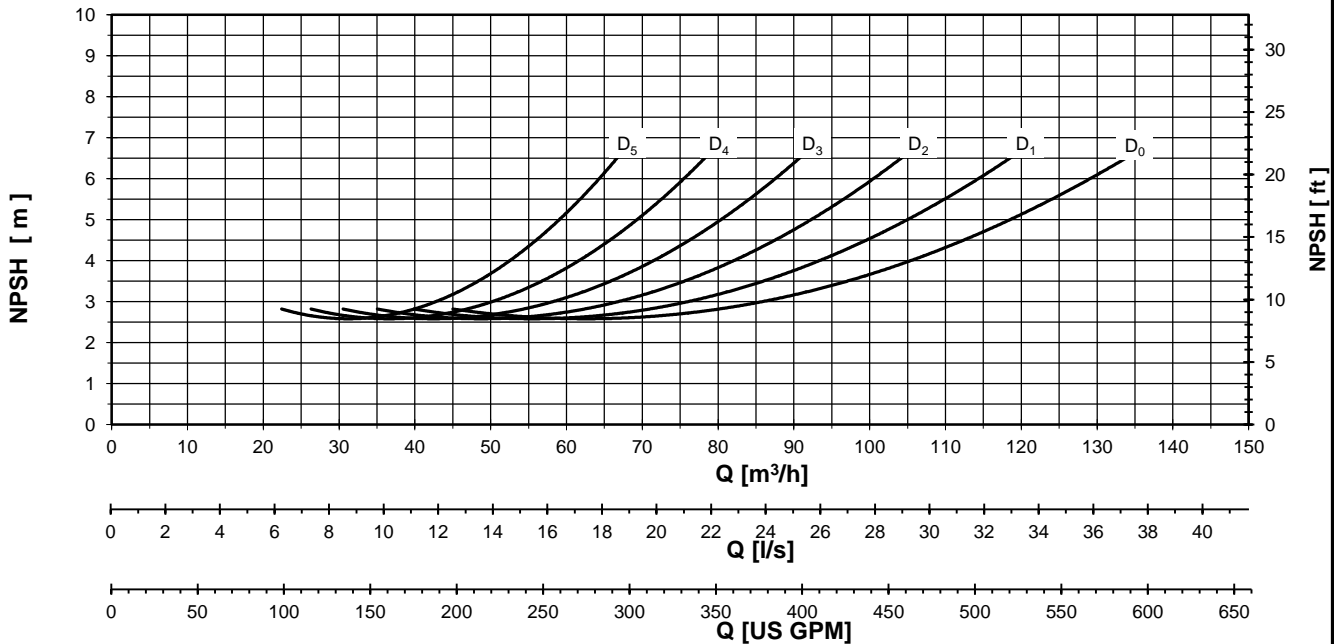
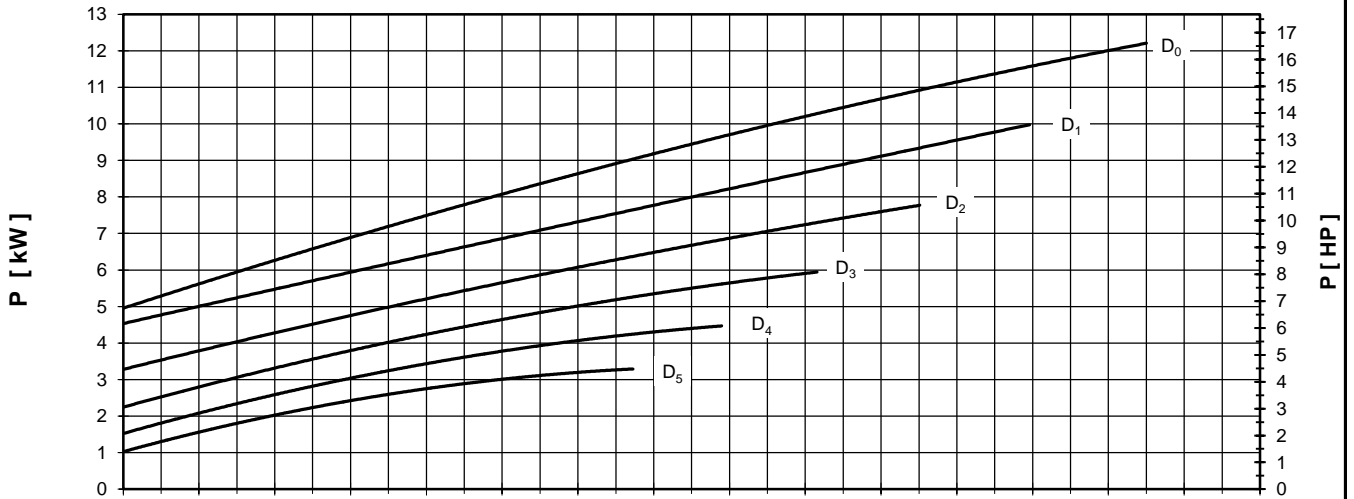
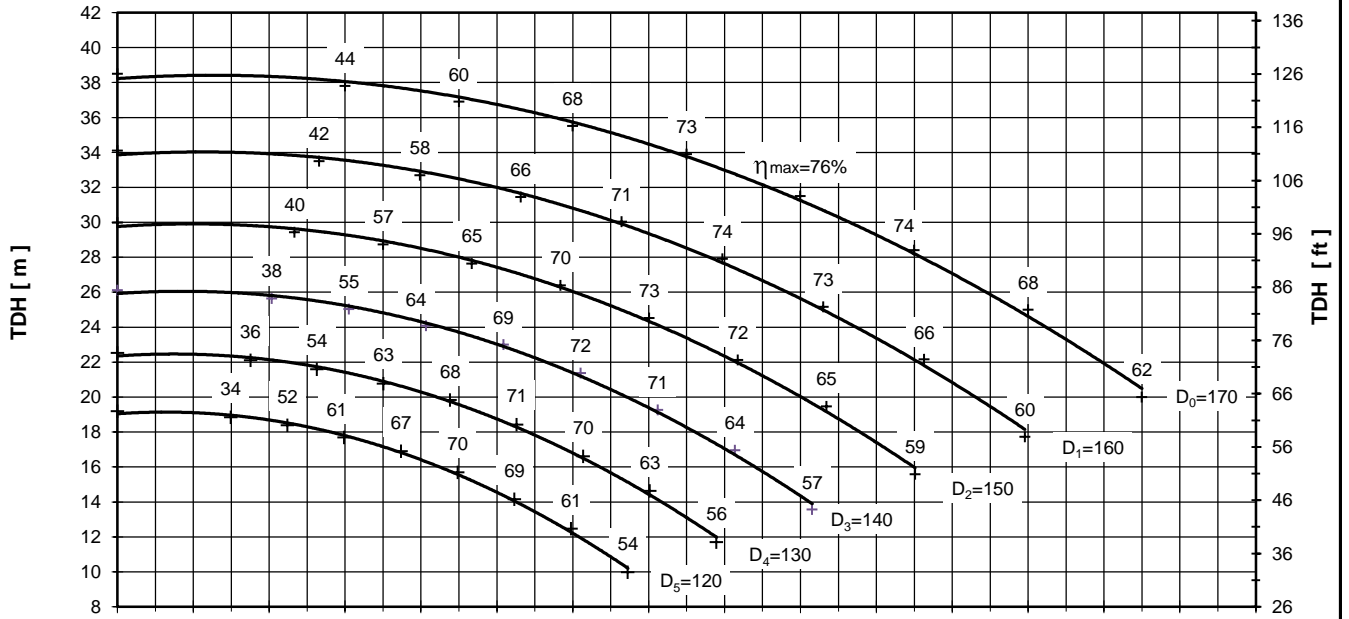

Performance curves are valid for clean cold water-kinematic viscosity 1 [mm²/s], density 1000 [kg/m³]. Methods and tolerances of presented performance curves are in accordance with ISO 9906 - Annex A

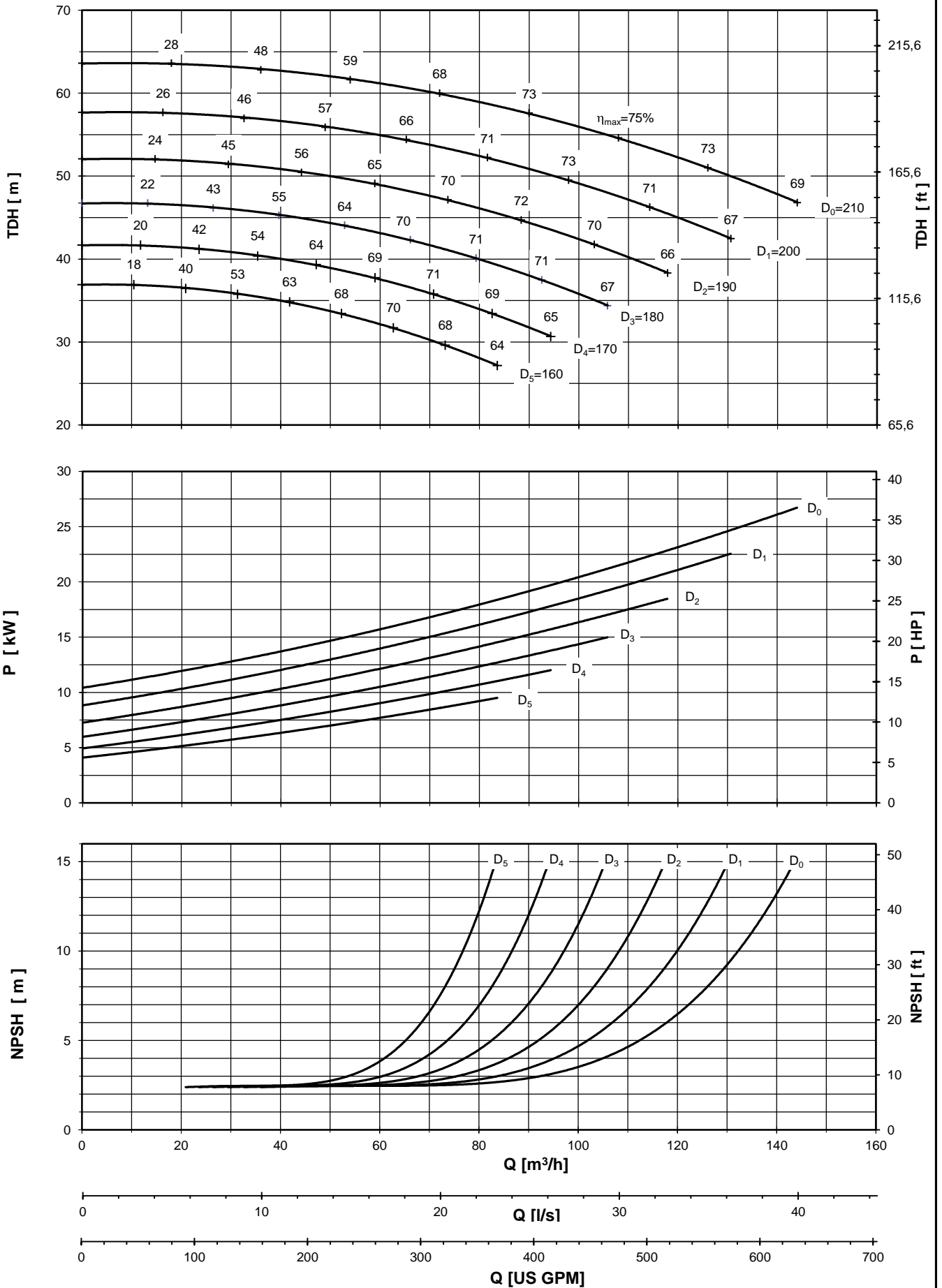

Performance curves are valid for clean cold water-kinematic viscosity 1 [mm<sup>2</sup>/s], density 1000 [kg/m<sup>3</sup>]. Methods and tolerances of presented performance curves are in accordance with ISO 9906 - Annex A



PUMP PERFORMANCE CURVES  
No. 4HD.0158.05

PUMP TYPE  
SCP 65 - 250  
2900 [rpm]

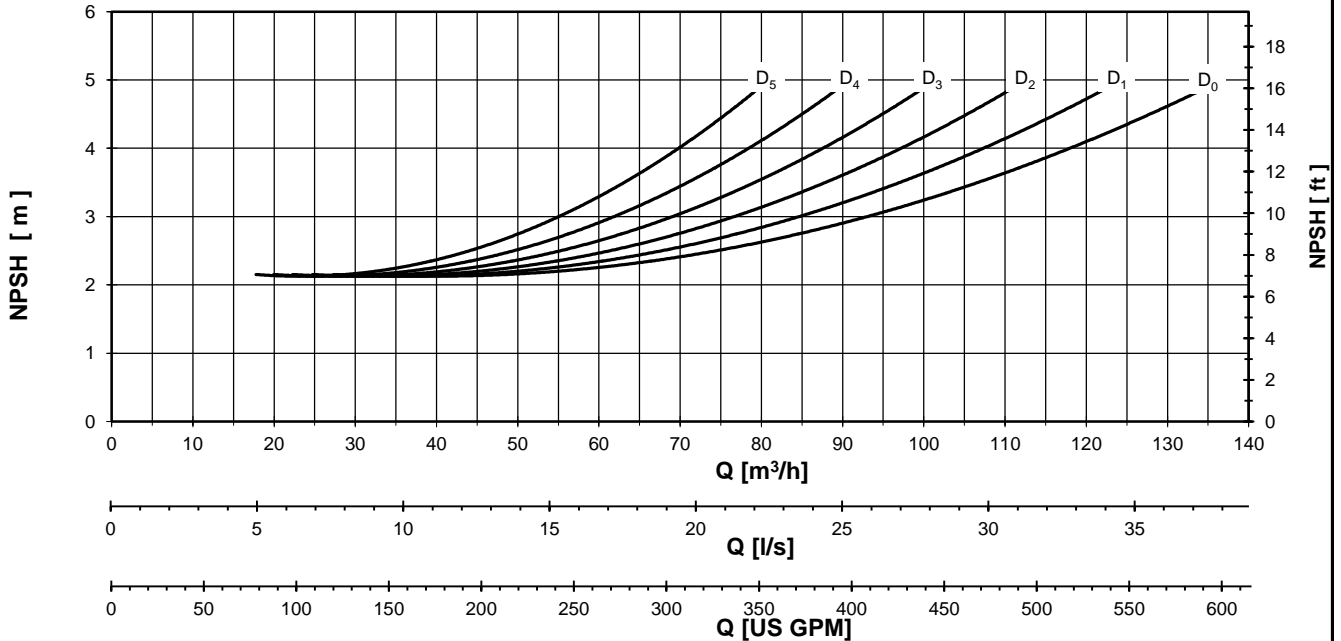
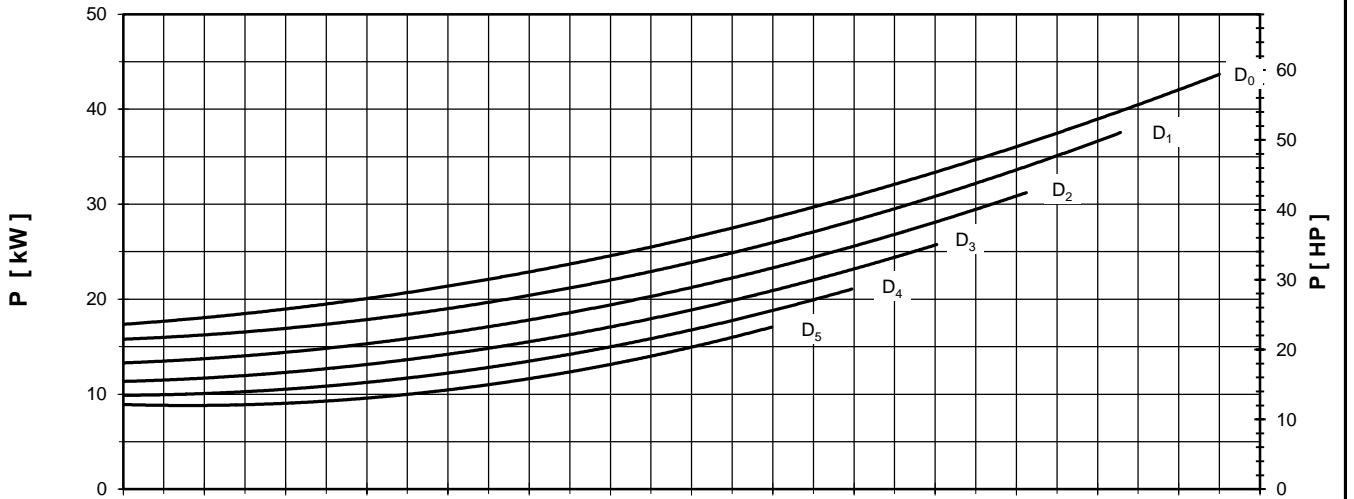
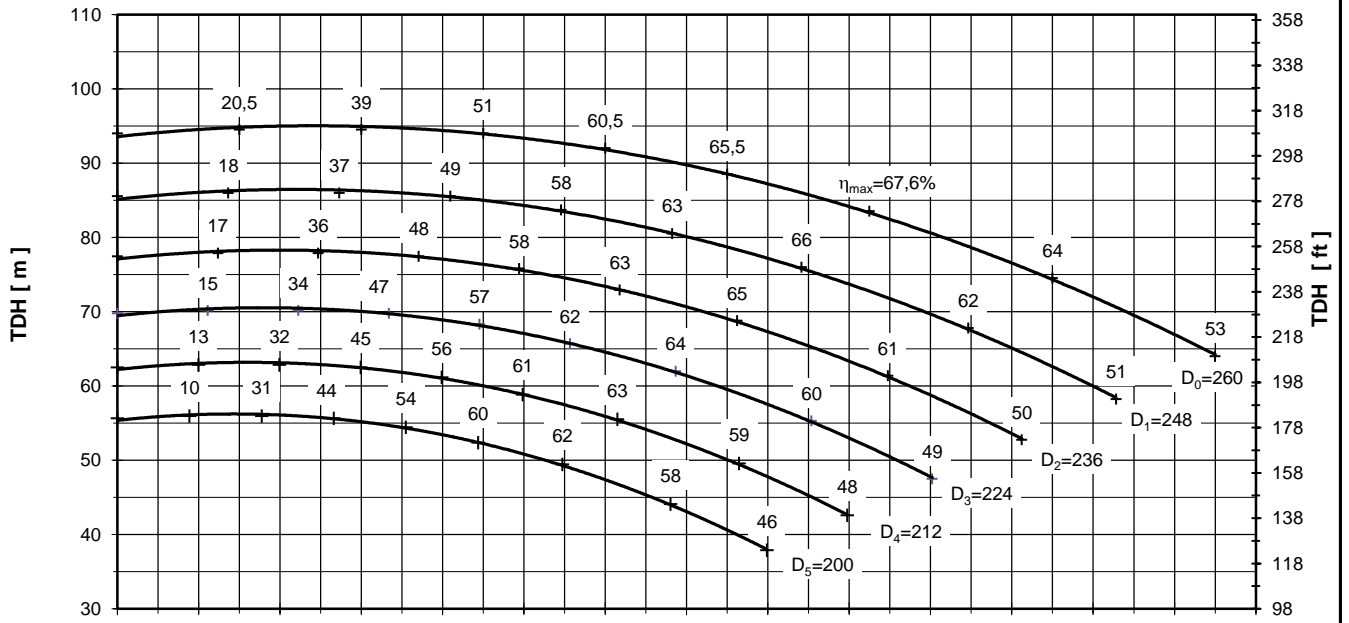

Performance curves are valid for clean cold water-kinematic viscosity 1 [mm²/s], density 1000 [kg/m³]. Methods and tolerances of presented performance curves are in accordance with ISO 9906 - Annex A



PUMP PERFORMANCE CURVES  
No. 4HD.0159.05

PUMP TYPE  
SCP 65 - 315  
2900 [rpm]

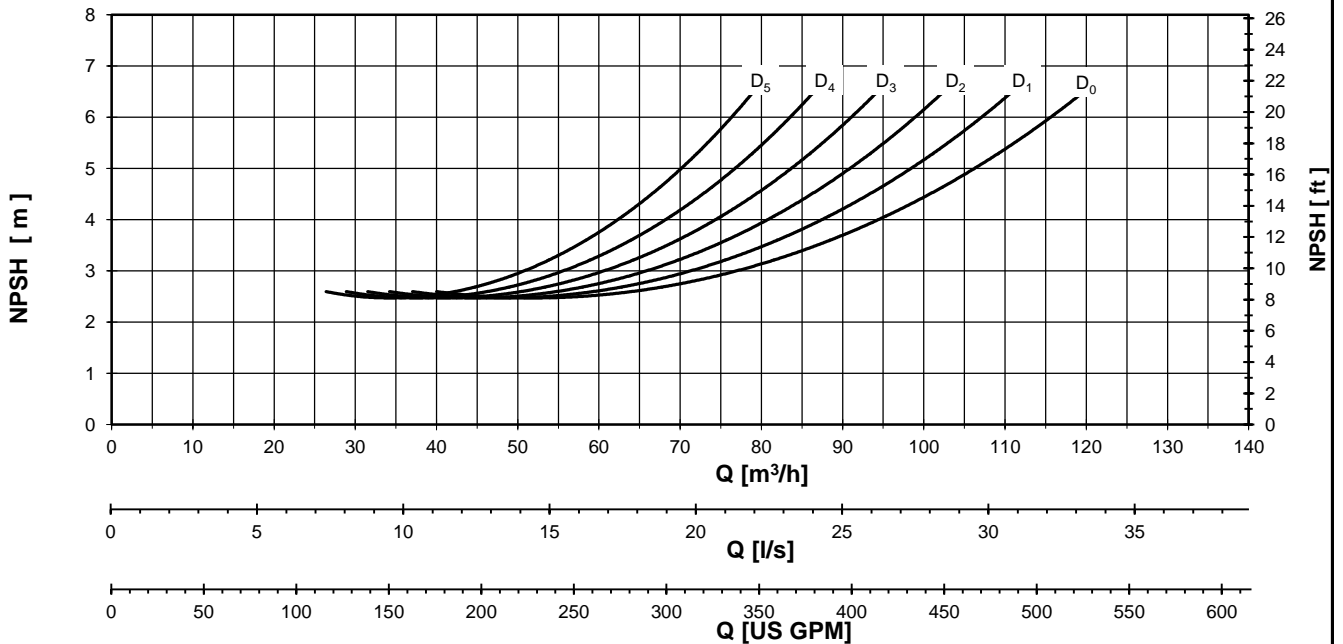
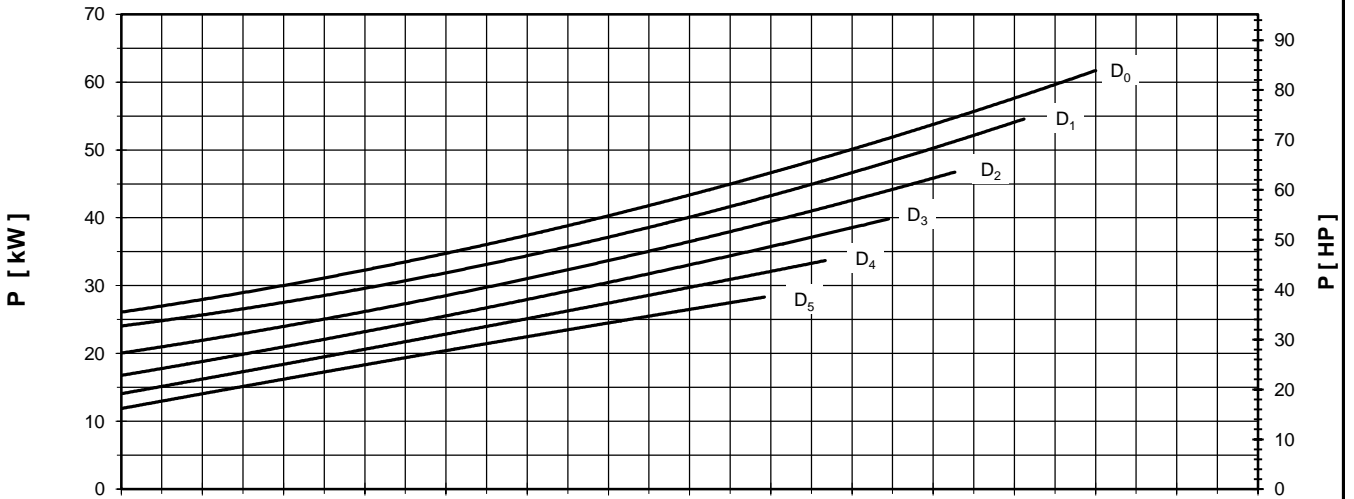
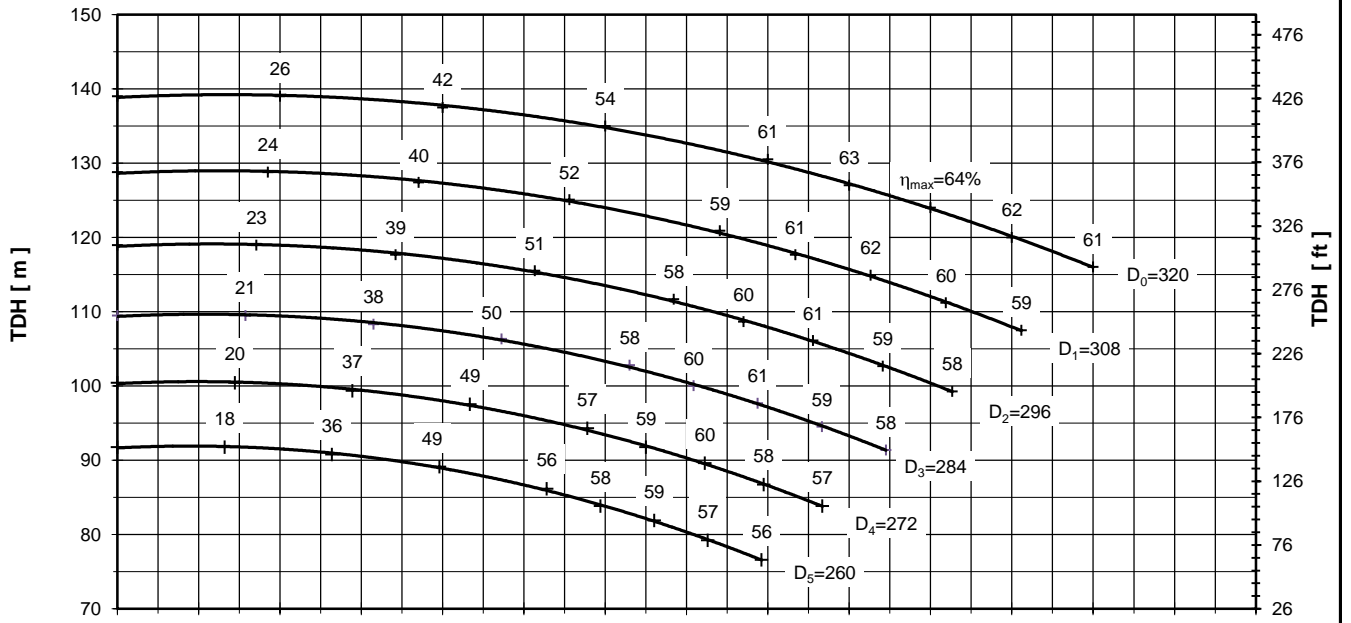

Performance curves are valid for clean cold water-kinematic viscosity 1 [mm²/s], density 1000 [kg/m³]. Methods and tolerances of presented performance curves are in accordance with ISO 9906 - Annex A



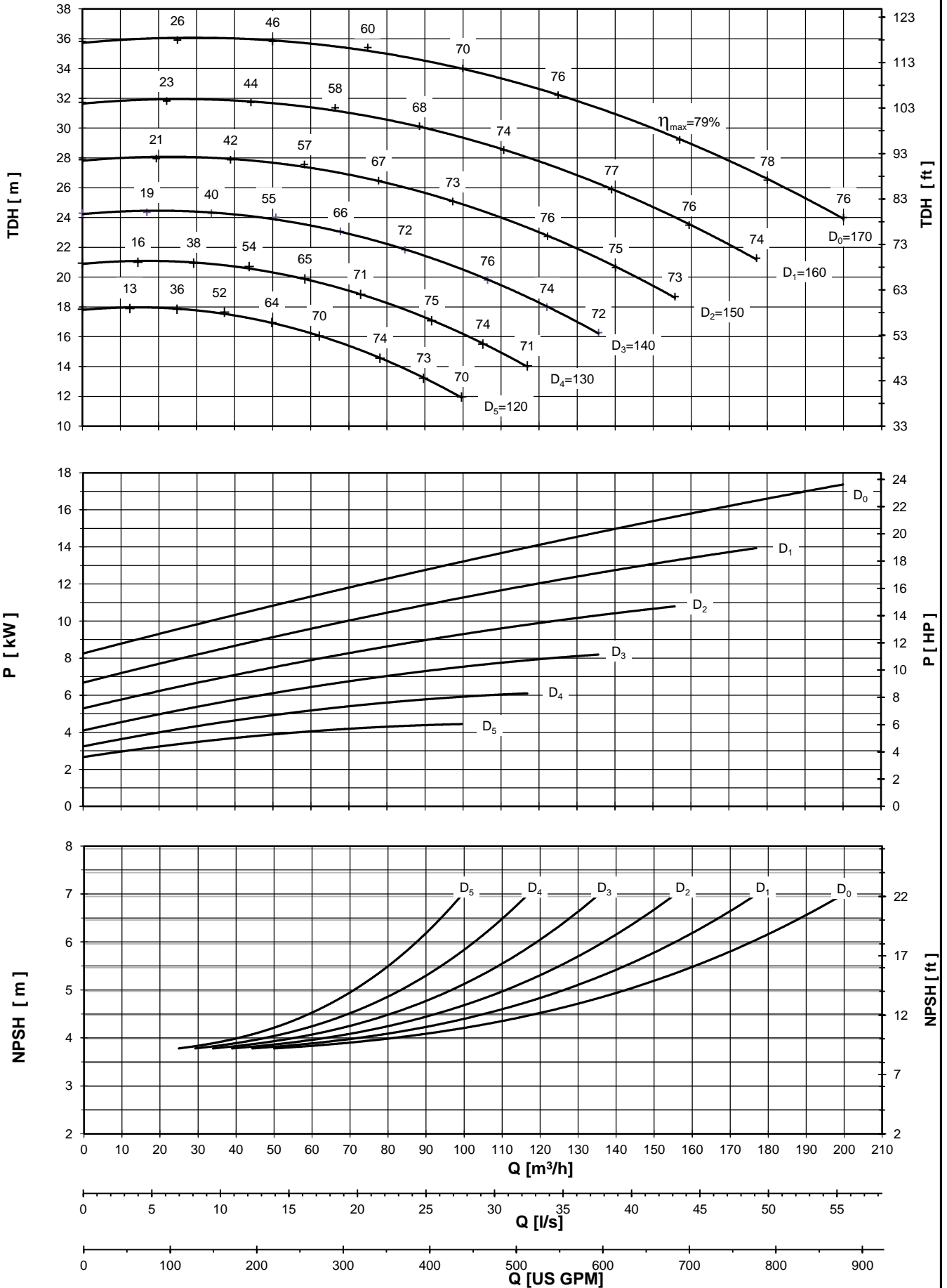

Performance curves are valid for clean cold water-kinematic viscosity 1 [mm<sup>2</sup>/s], density 1000 [kg/m<sup>3</sup>]. Methods and tolerances of presented performance curves are in accordance with ISO 9906 - Annex A

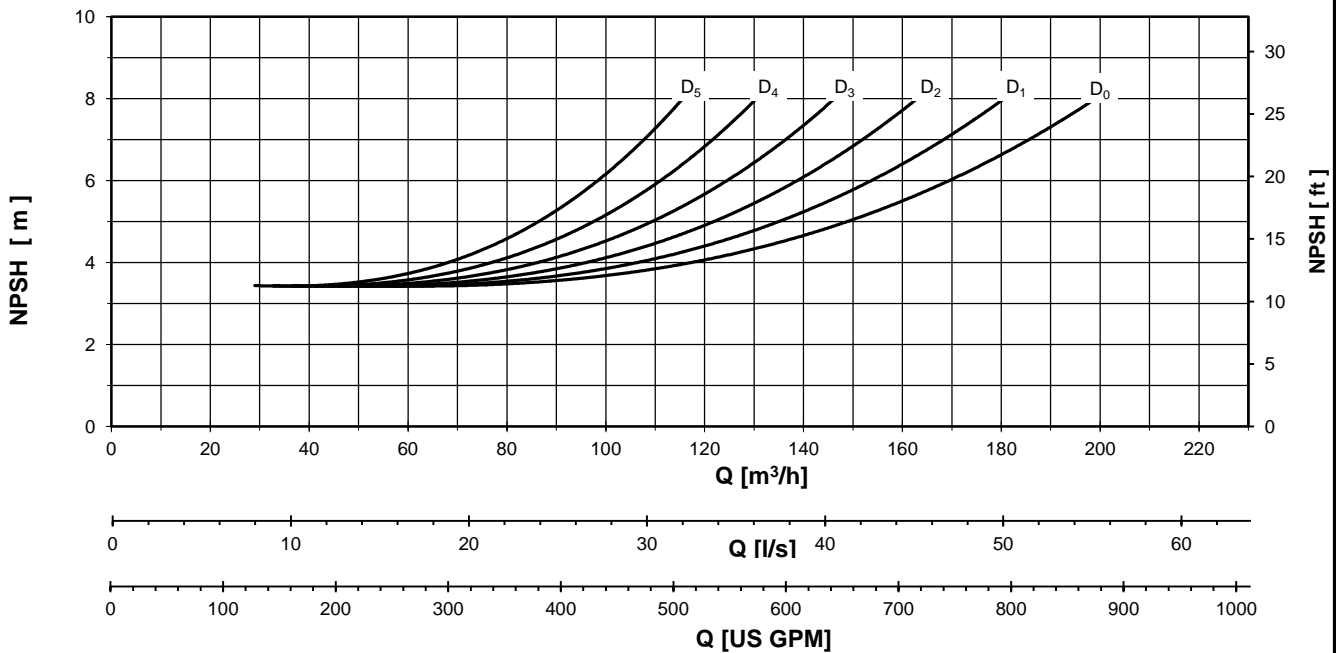
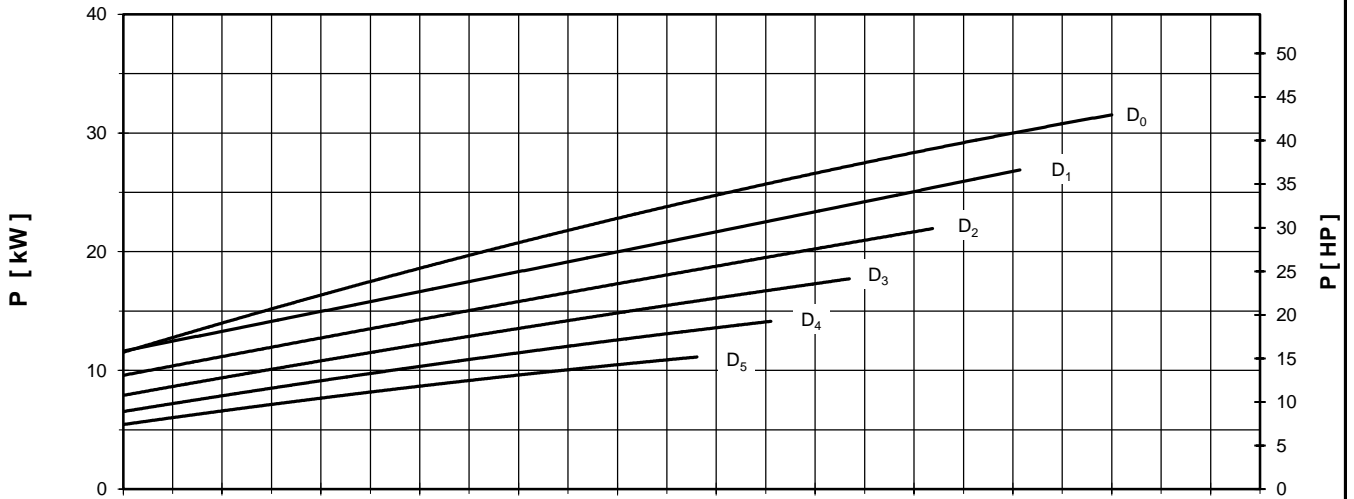
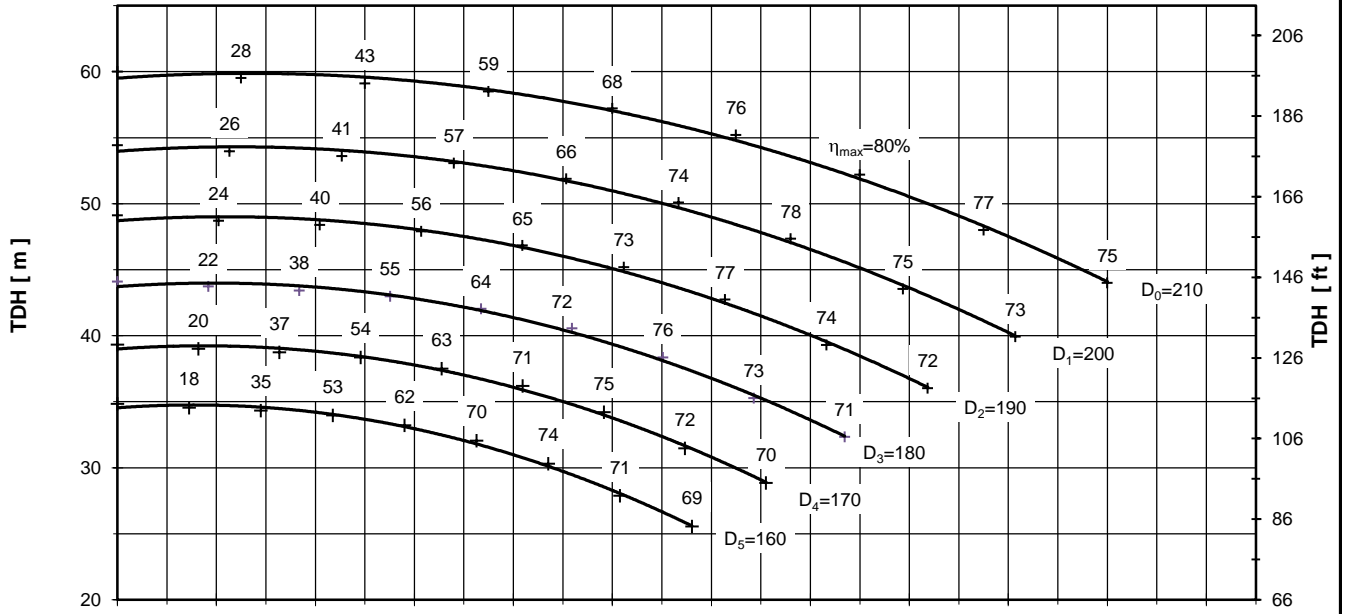

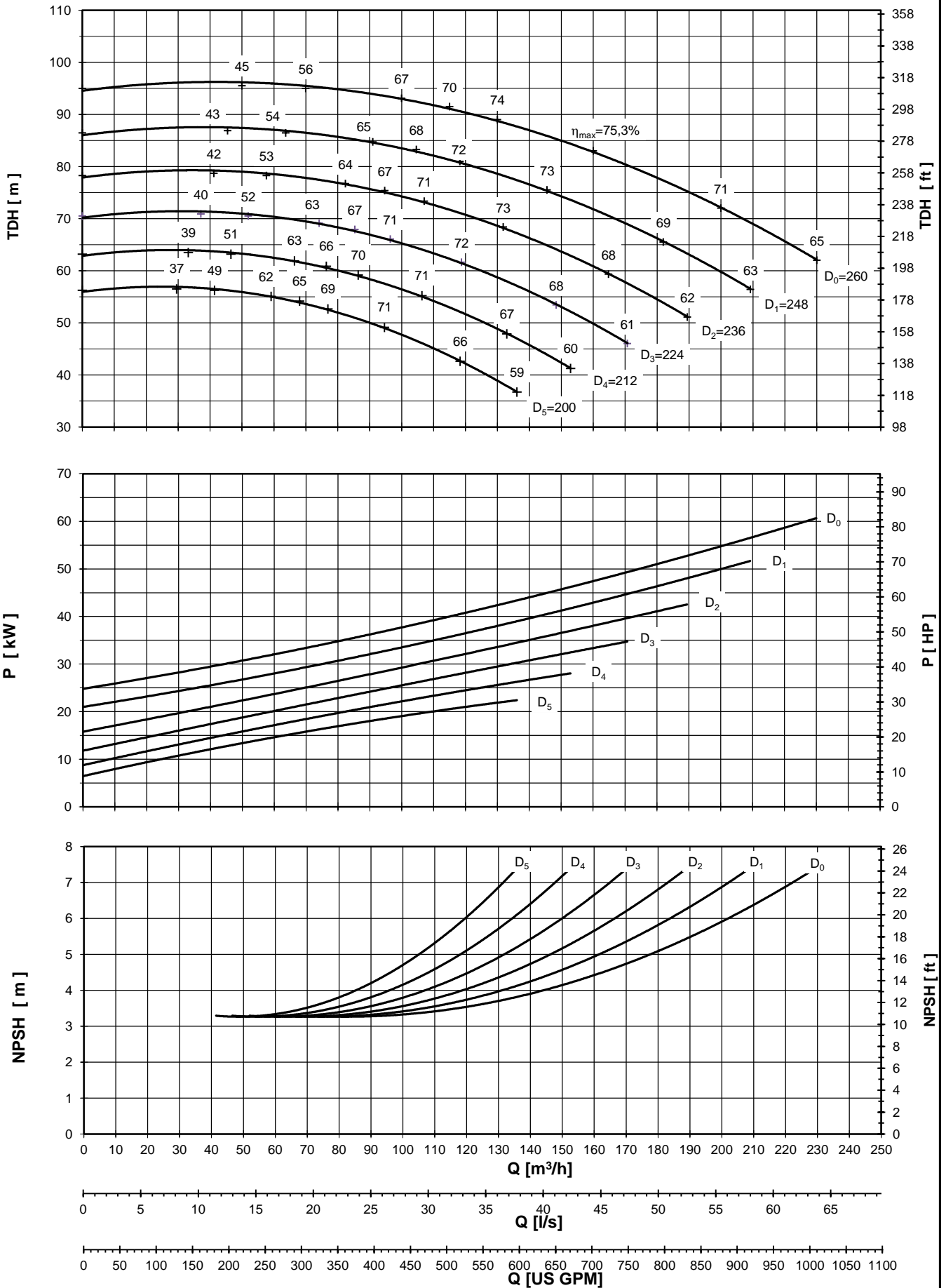

Performance curves are valid for clean cold water-kinematic viscosity 1 [mm<sup>2</sup>/s], density 1000 [kg/m<sup>3</sup>]. Methods and tolerances of presented performance curves are in accordance with ISO 9906 - Annex A



PUMP PERFORMANCE CURVES  
No. 4HD.0163.05

PUMP TYPE  
SCP 80 - 315  
2900 [rpm]

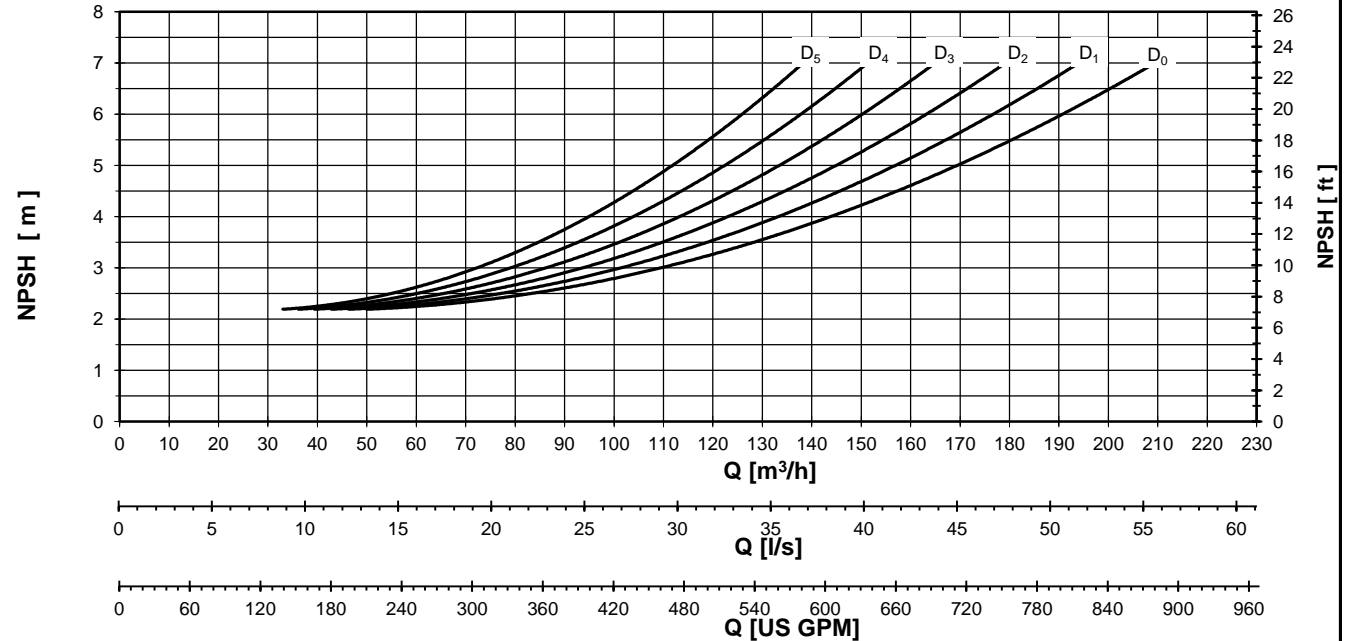
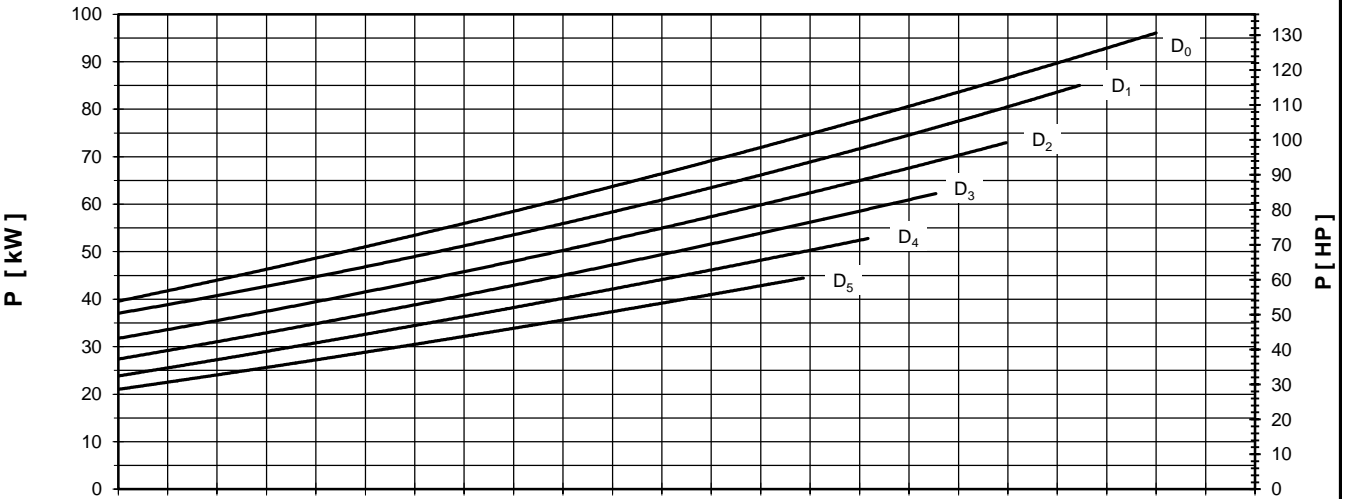
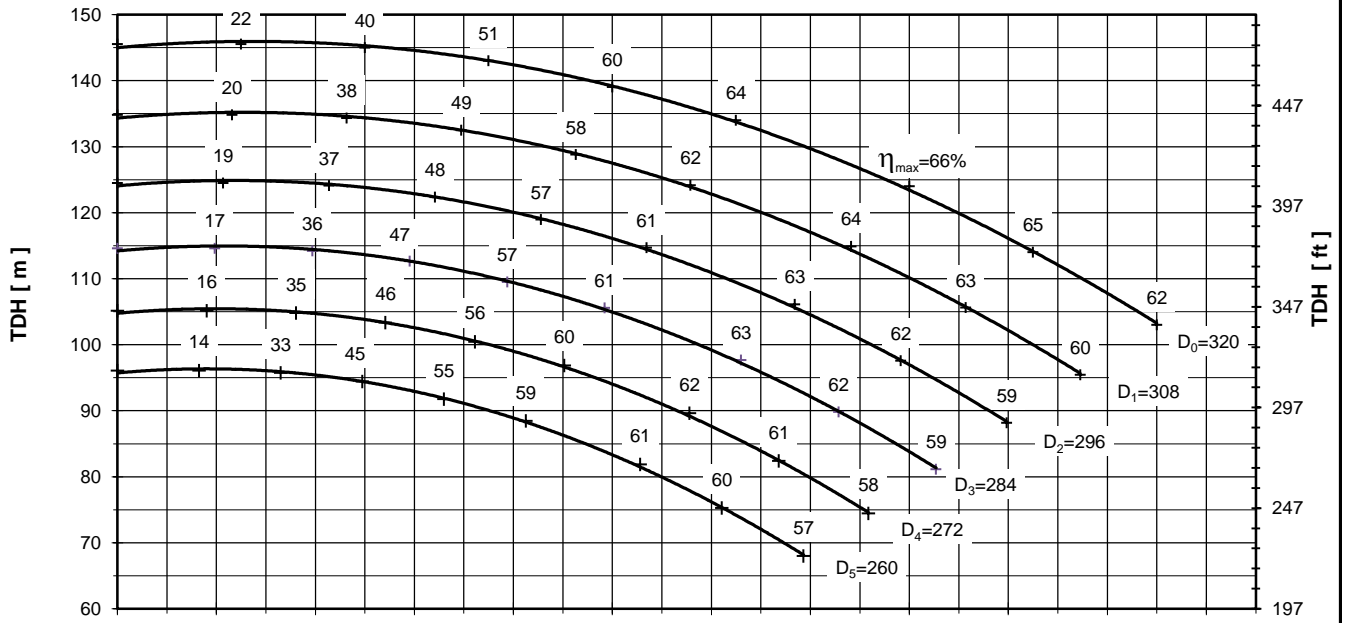

Performance curves are valid for clean cold water-kinematic viscosity 1 [mm²/s], density 1000 [kg/m³]. Methods and tolerances of presented performance curves are in accordance with ISO 9906 - Annex A

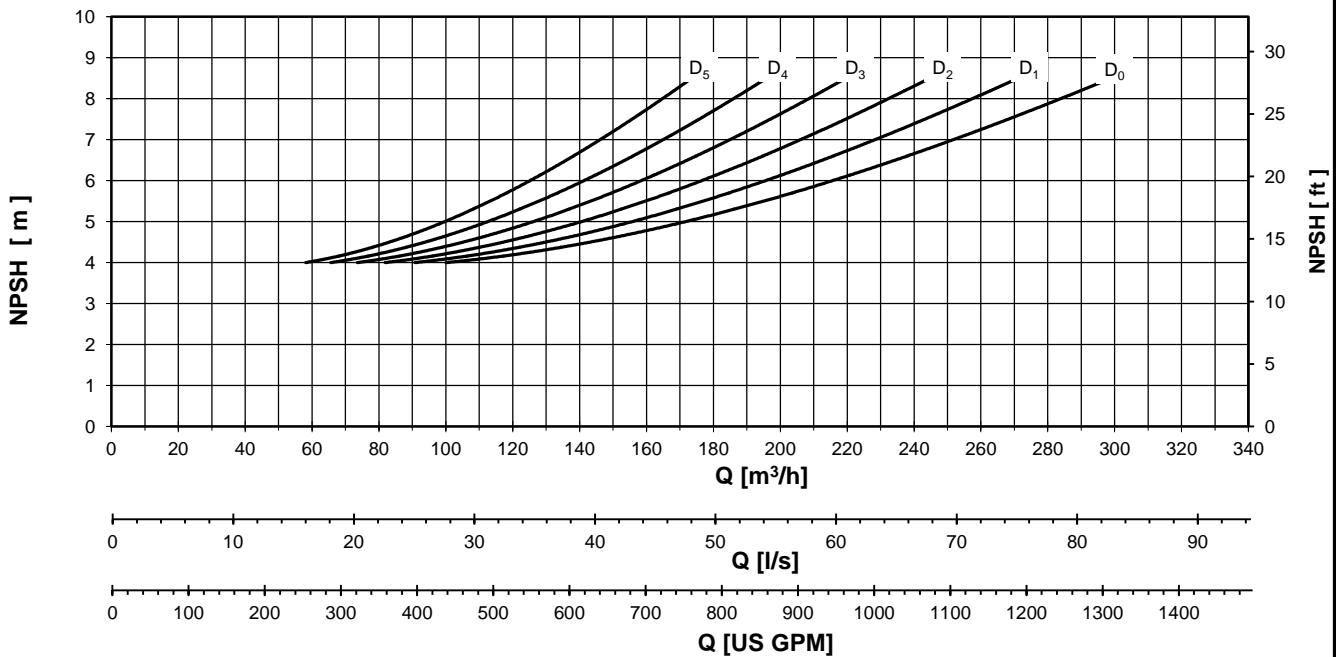
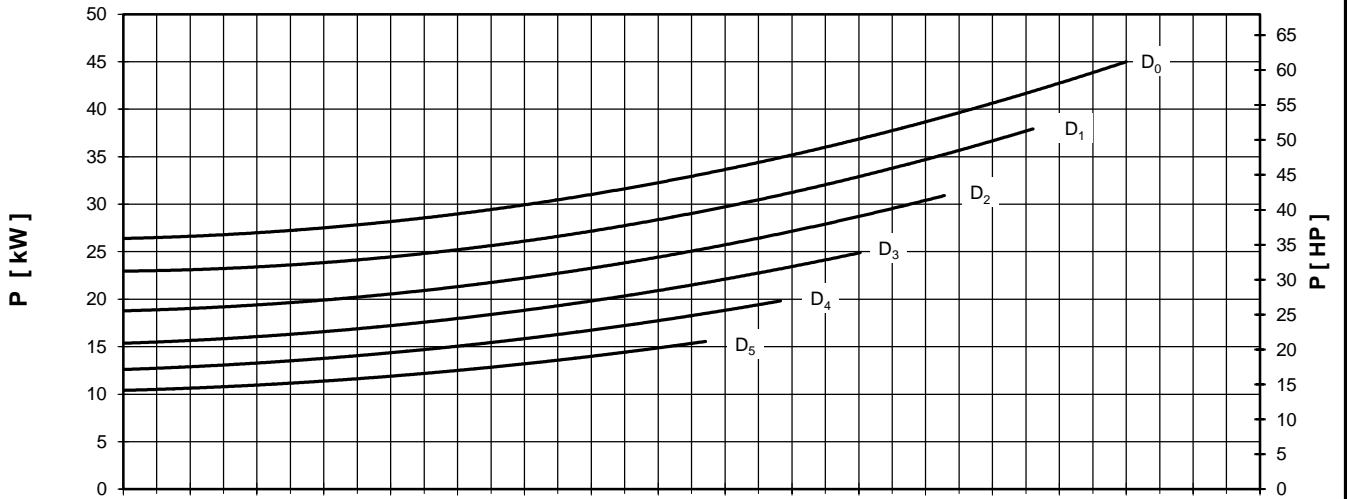
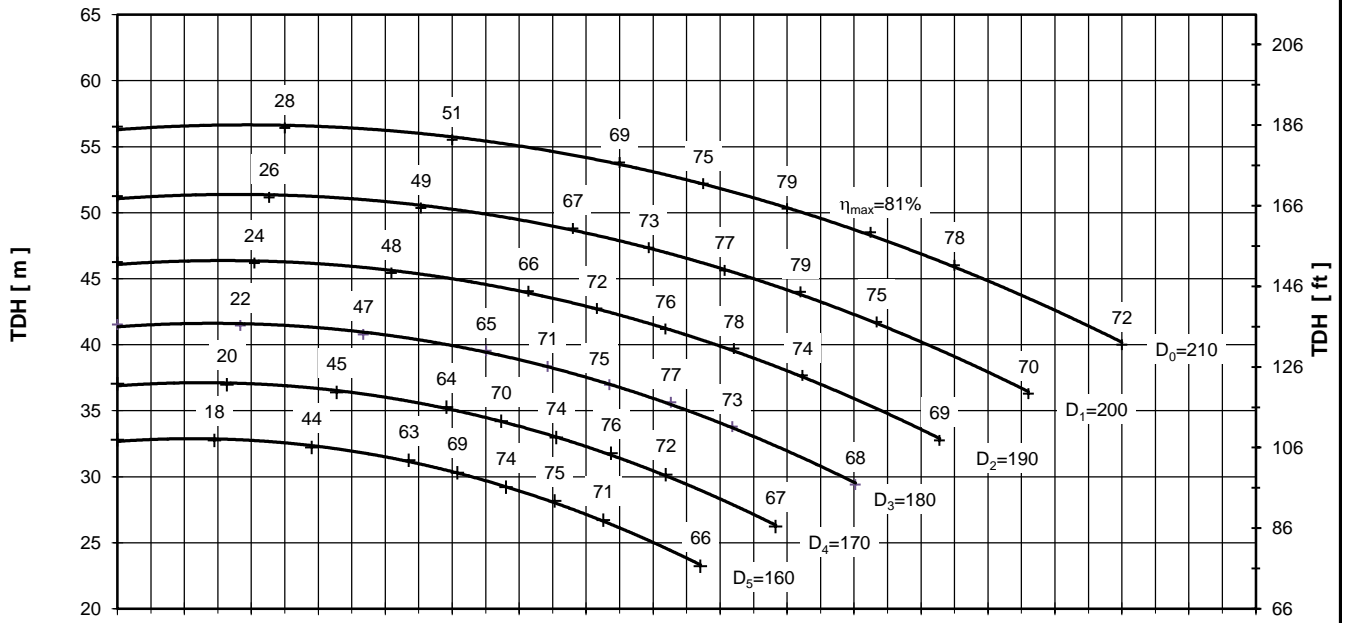

Performance curves are valid for clean cold water-kinematic viscosity 1 [mm²/s], density 1000 [kg/m³]. Methods and tolerances of presented performance curves are in accordance with ISO 9906 - Annex A

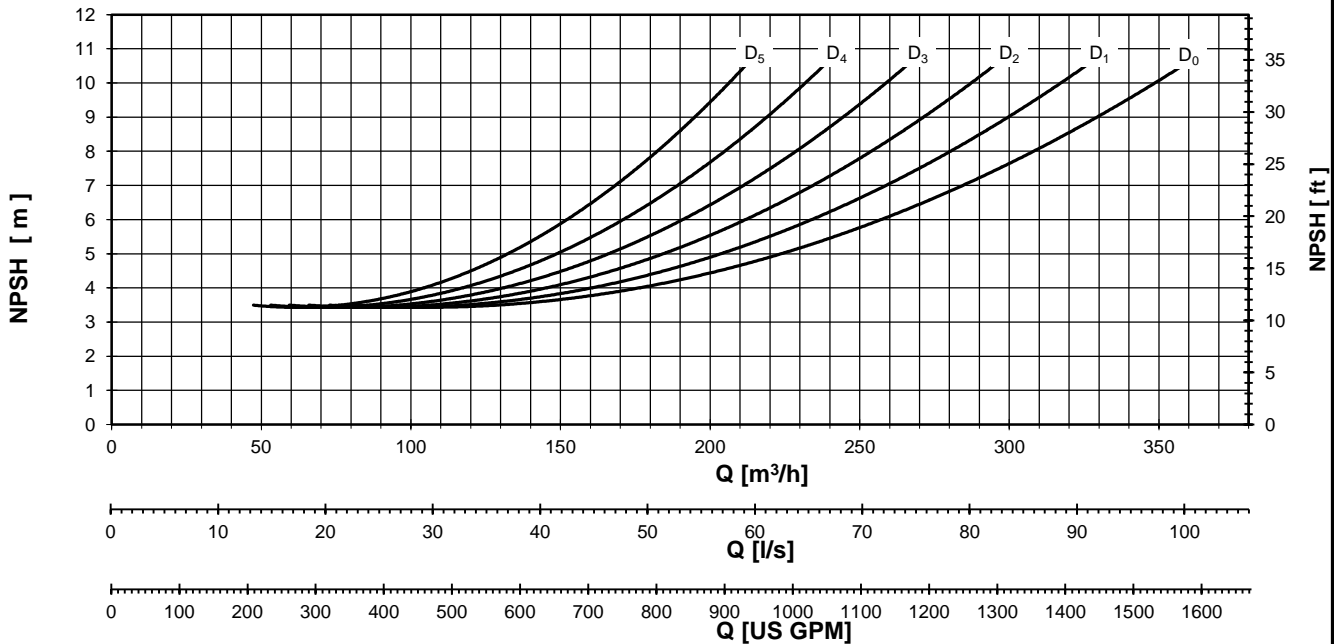
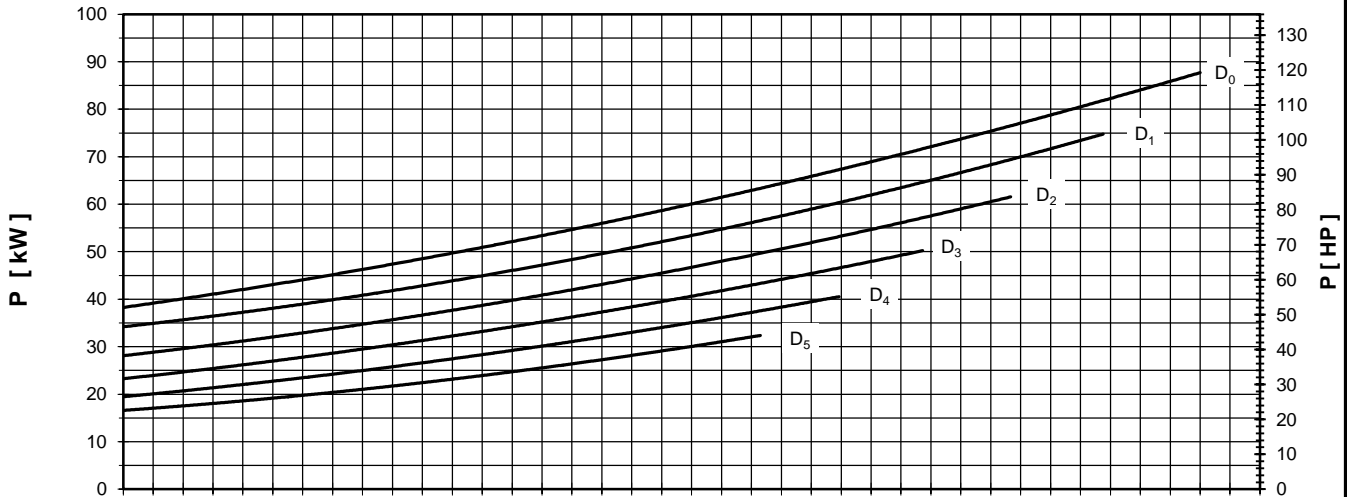
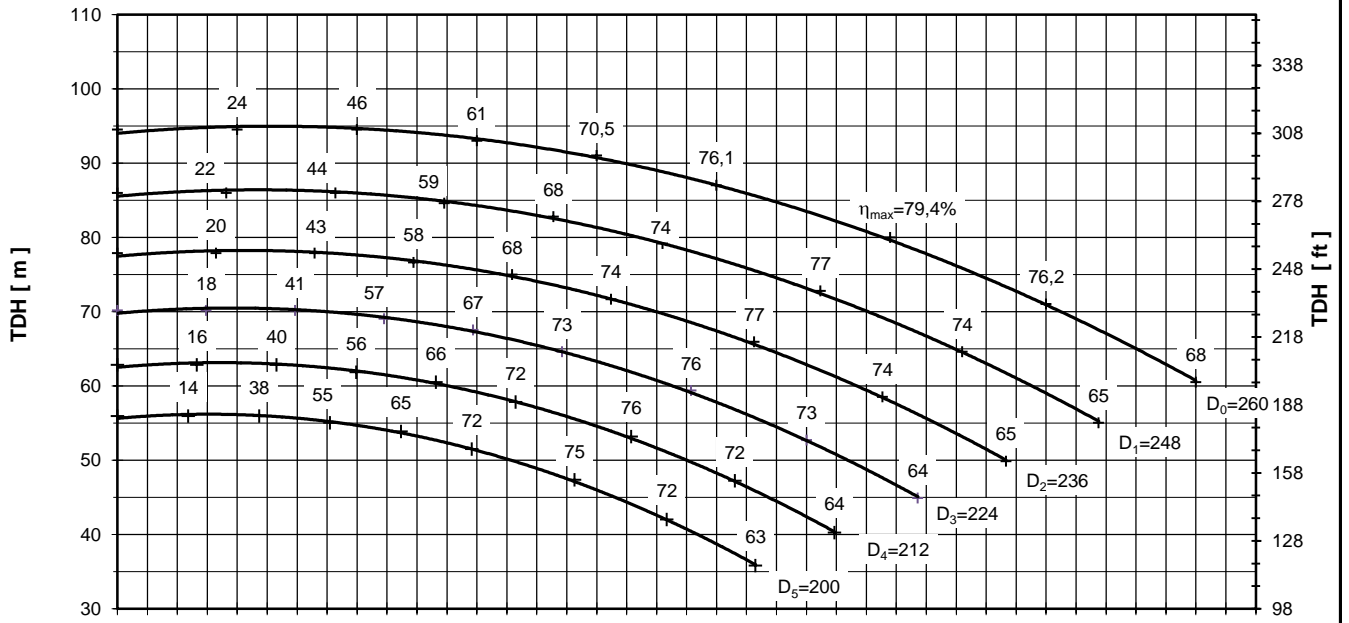



Pero Nakov Str. bb. 1000 Skopje, Republic of Macedonia  
Tel. +389 2 2549 817 / 818, Fax. +389 2 2549 833 / 834  
[www.pumpi.com.mk](http://www.pumpi.com.mk); e-mail: [info@pumpi.com.mk](mailto:info@pumpi.com.mk)



QUALITY MANAGEMENT SYSTEM<sup>™</sup>  
ISO 9001:2008

