

AX40K

Mechanical seals | Mechanical seals for pumps | Pusher seals



Features

- Stationary springs
- Balanced
- Independent of direction of rotation
- Independent of pressure direction

Advantages

- Balanced seal in the installation space of a unbalanced seal
- Springs protected from the product
- Suitable-to-ceramic design
- Smooth external contours

Operating range

Shaft diameter: $d_1 = 18 \dots 300 \text{ mm}$

Pressure: $p_1 = 25 \text{ bar (363 PSI)}$

Temperature: $t = -40 \dots 220^\circ \text{C} (-40 \dots 428^\circ \text{F})$

Sliding velocity: $v_g = 20 \text{ m/s (66 ft/s)}$

Materials

Seal face: Silicon Carbide (Q1, Q2)

Seat: Carbon graphite resin impregnated (B),

Silicon carbide (Q1, Q2)

Secondary seals:

EPDM (E), FKM (V), FFKM (K)

Springs: CrNiMo steel (G)

Metal parts: CrNiMo steel (G)

Standards and approvals

- EN 12756

- Process industry
- Oil and gas industry
- Refining technology
- Petrochemical industry
- Chemical industry
- Pharmaceutical industry
- Power plant technology
- Pulp and paper industry
- Water and waste water technology
- Mining industry
- Building services industry
- Food and beverage industry
- Shipbuilding
- Sugar industry
- Metal production and processing

RELY ON EXCELLENCE

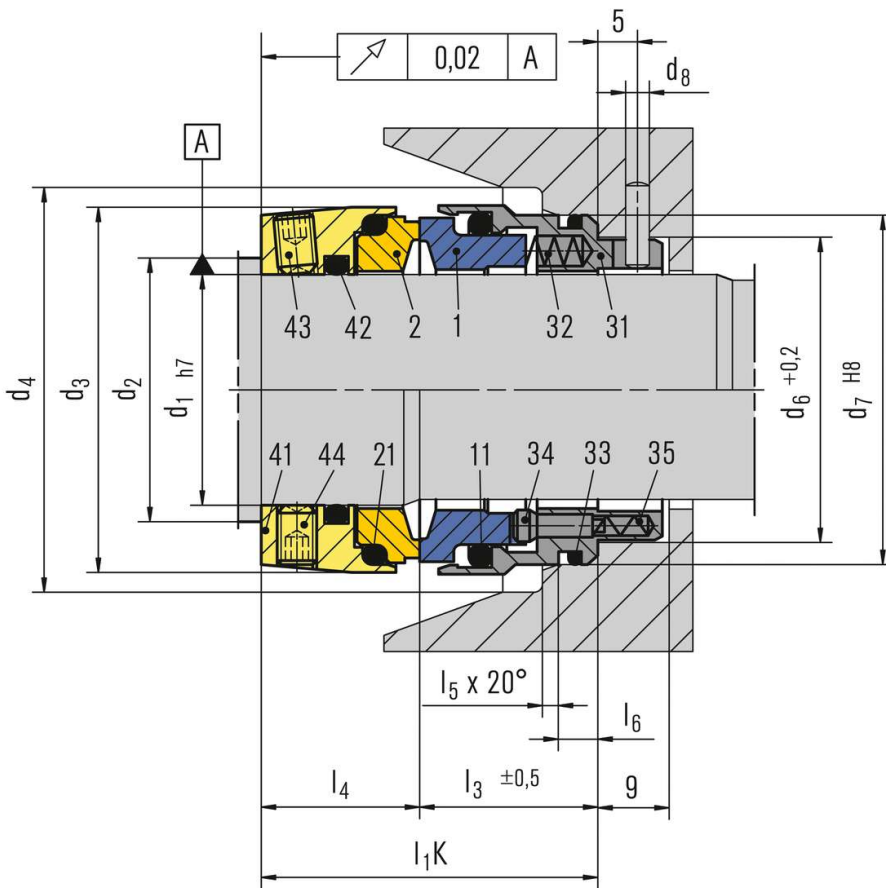

Item	Description
1	Seal ring
2	Mating ring
41	Adjusting ring
11, 21, 33, 42	O-Ring
31	Housing
32, 35	Spring
34	Pin
43, 44	Set screw

All technical specifications are based on extensive tests and our many years of experience. The diversity of possible applications, however, means that they can serve only as guide values.

We must be notified of the exact conditions of application before we can provide any guarantee for a specific case. This is subject to change.

RELY ON EXCELLENCE**Installation, details, options**

Mating ring design $d1 \geq 70$ mm
Item 45: Pin

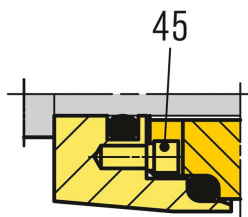
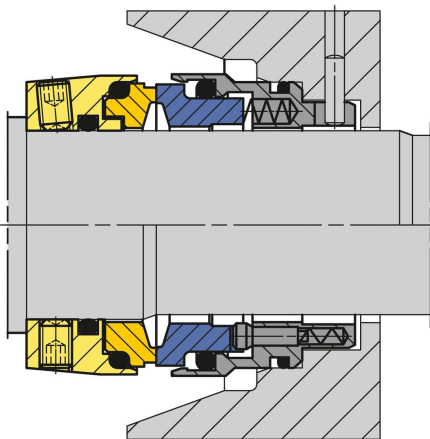
**Product variants****AX40KG**

Dimensions and design characteristics as AX40K
The torque transmission at the seal ring and the mating ring is form locked. Equally at the circumference of the adjusting ring arranged drivers allow high torques. This variant is applied for media which tend to jamming or if high starting torque is expected.

Seal face: Silicon carbide (Q1, Q2)
Seat: Silicon carbide (Q1, Q2)

RELY ON EXCELLENCE

Dimensions

d1	d2	d3*	l1k**	l3	l4	d4	d6	d7	d8	l5	l6
18	22	35	45	26.5	18.5	40	27	33	3	2	5
20	24	37	45	26.5	18.5	42	29	35	3	2	5
22	26	39	45	26.5	18.5	44	31	37	3	2	5
24	28	41	40	21.5	18.5	46	33	39	3	2	5
25	30	42	40	21.5	18.5	47	34	40	3	2	5
28	33	45	42.5	22.5	20	50	37	43	3	2	5
30	35	47	42.5	22.5	20	52	39	45	3	2	5
32	38	50	42.5	22.5	20	55	42	48	3	2	5
33	38	50	42.5	22.5	20	55	42	48	3	2	5
35	40	52	42.5	22.5	20	57	44	50	3	2	5
38	43	58	45	23.5	21.5	63	49	56	4	2	6
40	45	60	45	23.5	21.5	65	51	58	4	2	6
43	48	63	45	23.5	21.5	68	54	61	4	2	6
45	50	65	45	23.5	21.5	70	56	63	4	2	6
48	53	68	45	23.5	21.5	73	59	66	4	2	6
50	55	72	47.5	25.5	22	77	62	70	4	2.5	6
53	58	75	47.5	25.5	22	80	65	73	4	2.5	6
55	60	77	47.5	25.5	22	82	67	75	4	2.5	6
58	63	81	52.5	27.5	25	86	70	78	4	2.5	6
60	65	83	52.5	27.5	25	88	72	80	4	2.5	6
63	68	86	52.5	27.5	25	91	75	83	4	2.5	6
65	70	88	52.5	27.5	25	93	77	85	4	2.5	6
70	75	95	60	30.5	29.5	100	83	92	4	2.5	7
75	80	100	60	30.5	29.5	105	88	97	4	2.5	7
80	85	108	60	30.5	29.5	113	95	105	4	3	7
85	90	113	60	30.5	29.5	118	100	110	4	3	7
90	95	118	65	34	31	123	105	115	4	3	7
95	100	123	65	34	31	128	110	120	4	3	7
100	105	128	65	34	31	133	115	125	4	3	7

Dimensions in millimeter

* Dimension d₃ acc. to EN 12756 exceeded

** d1 = 18 ... 22: l_{1k} acc. to EN 12756 Form B,

d1 = 24 ... 100: l_{1k} acc. to EN 12756 Form U

All technical specifications are based on extensive tests and our many years of experience. The diversity of possible applications, however, means that they can serve only as guide values.

We must be notified of the exact conditions of application before we can provide any guarantee for a specific case. This is subject to change.