

## 4AP – for KSB's Amaprop submersible mixer

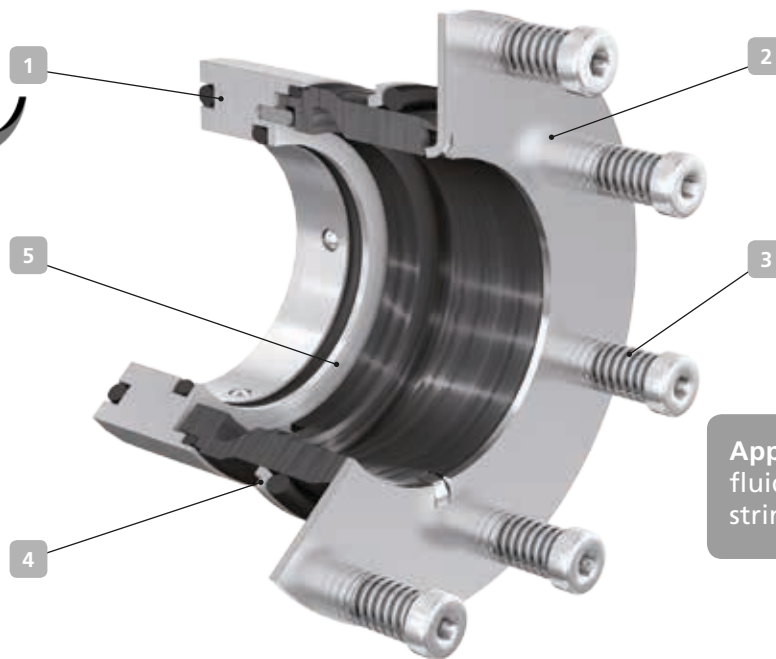

**Applications:**  
fluids containing long fibres and stringy particles

### 1 Compact

Single mechanical seal, bi-directional, tailored to the seal installation space and the submersible mixer's requirements.

### 2 Versatile

For all operating conditions the submersible mixer is approved for.

### 3 Dependable

Stationary design, balanced, multiple springs located outside the fluid handled in the oil reservoir. Thus, the springs are insensitive to contamination and provide uniform surface pressure across the seal faces, ensuring a long service life.

### 4 Robust

Suitable for all fluids with high solids content and those containing long fibres.

### 5 Service-friendly

Easy to install, design provides for a fixed adjusting dimension.

#### Technical description

Design	Single mechanical seal
Type	Stationary, balanced
Springs	Multi-spring arrangement
Direction of rotation	Bi-directional

#### Additional information

Amaprop's shaft is sealed with two mechanical seals in tandem arrangement. Only the inboard seal is replaced with KSB's seal 4AP

Various wear part kits available, see ZN3302

#### Materials

Primary ring	SiC (Q1)
Mating ring	SiC (Q1)
Elastomers	FKM (V)
Springs	1.4571 (G)
Other Components	1.4122 (E)

Other material combinations on request

#### Technical data

Operating pressure	Up to 1.2 bar, dynamic Up to 1.2 bar, static
Temperature	-10 °C to 65 °C
Bearing bracket (seal size)	055
Business type	Standard