

# 4EDCB8S – single mechanical seals to API 682, 4<sup>th</sup> edition (category 1)

For KSB's MCPK pump type series

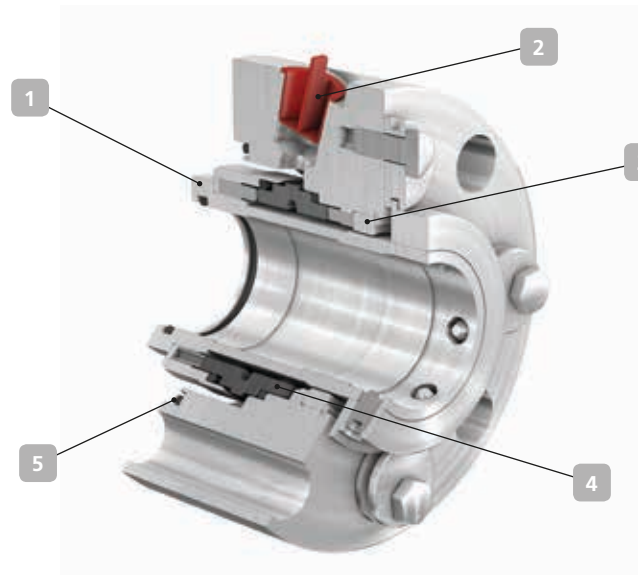

**Applications:**  
chemical and petrochemical industries

## Arrangement 1 Contacting, single, product-lubricated and balanced cartridge seal

### 1 Compact

The single cartridge seal is especially designed for use in the standardised installation spaces of the non-API pump MCPK (CPKN + CPK possible).

### 2 Flexible

The mechanical seal can be connected to all common API Plans, such as 01, 02, 11, 31, 32 + 61 (62) and 23 + 61 (62).

### 3 Dependable

Floating throttling bush for optional connection of a gas or steam quench. This prevents outboard incrustations at the seal.

### 4 Robust

The mechanical seal is available in a hard-soft combination of silicon carbide and carbon graphite, or in a hard-hard combination of silicon carbide and silicon carbide.

### 5 Materials

The seal contains O-rings as secondary sealing elements. They are available in different material variants.

#### Technical description

Category	I
Type	A
Arrangement	1
Design	Cartridge
Additional information	Various wear part kits available on request

#### Materials

Primary ring	"A" carbon (A) / SiC-Si (Q2)
Mating ring	SiC-Si (Q2)
Elastomers	FKM (V) / FFKM (K)
Springs	2.4610 (M)
Other Components	1.4571 (G)
Other material combinations on request	

#### Technical data

Pressure	Up to 20 bar
Temperature	-10 to 200 °C
Bearing bracket (seal size)	CS40 (033), CS50 (043), CS60 (053), CS80 (065)
Business type	Standard (KSB EasySelect)
Higher application limits on request	

# 4EDTR6HT & D – double metal-bellows mechanical seals to API 682, 4<sup>th</sup> edition

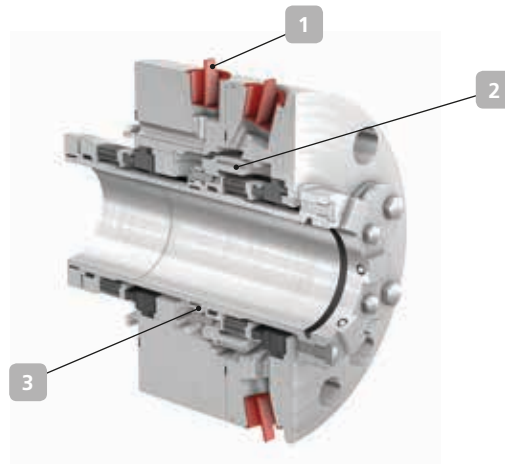

**Applications:**  
API 682 applications in the chemical and petrochemical industries

## Arrangements 2 or 3 Contacting, double, product-lubricated and balanced metal-bellows cartridge seal

### 1 Flexible

The double metal-bellows seal can be connected to all common API Plans, such as 01, 02, 11, 31, 32 + 52, 53 (A, B, C) and 23 + 52, 53 (A, B, C). The seals are available for all of KSB's API pumps.

### 2 Safe

The space between the two mechanical seals is flushed with a buffer or barrier fluid, depending on the application. This completely absorbs any leakage of the fluid pumped. In addition, the heat is transported away from this area. The double pressure balanced mechanical seal can be operated with pressurised barrier fluid or unpressurised buffer fluid.

### 3 Materials

The mechanical seal is available in a hard-soft combination of silicon carbide and carbon graphite, or in a hard-hard combination of silicon carbide and silicon carbide. The bellows made of Inconel® 718 and the secondary sealing elements made of pure graphite have an excellent chemical resistance and are especially suited for applications with high temperatures.

## Variants

### Variant 4EDTR6HT

Double metal-bellows seal for use with unpressurised buffer fluid in the space between the two seals (API Plan 52).

### Variant 4EDTR6HD

Double metal-bellows seal for use with pressurised barrier fluid in the space between the two seals (API Plan 53).

### Technical data

Shaft diameter	50 to 120 mm
Pressure	Up to 20 bar
Temperature	-75 to 400 °C

Higher application limits on request

### Materials

Inboard	Primary ring "A" carbon (A) / SiC-Si (Q2) Mating ring SiC-Si (Q2)
Outboard	Primary ring "A" carbon (A) Mating ring SiC-Si (Q2)
Secondary sealing elements	Statotherm® (G)
Metal bellows	Inconel® 718 (M6)
Other Components	Carpenter® 42 (T4)

Other material combinations on request

### Technical description

Category	II or III
Type	C
Arrangement	2 or 3
Design	Cartridge

Additional information      Various wear part kits available on request