

TYPE 7700D/7700W

DOUBLE OPPOSED CARTRIDGE MIXER SEAL

Technical Specification

- A – Seat/Mating Ring
- B – Face/Primary Ring
- C – Retainer
- D – Sleeve
- E – Collar
- F – Gland Plate

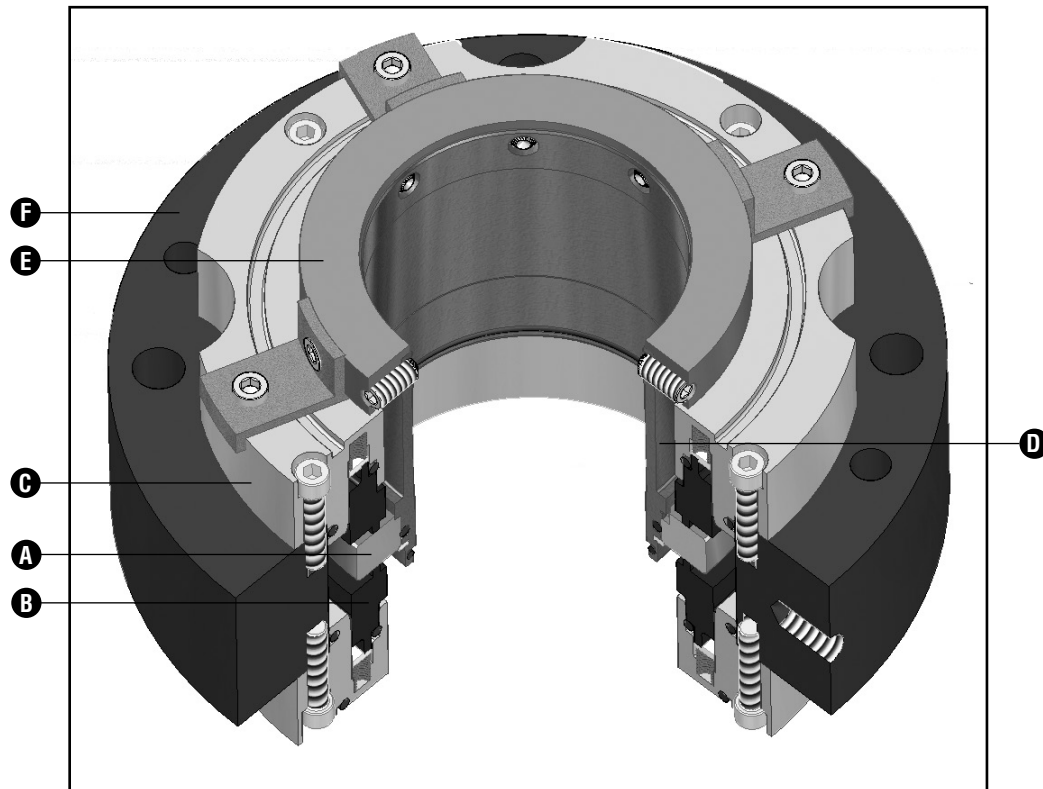

Product Description

The Type 7700 Series is a heavy-duty cartridge seal intended for use in critical mixing applications where durability and consistent performance are critical. Dual wet running or dry running designs with modular debris well and bearing housing are available to suit the requirements of the application. Special attention to internal clearances and the rotating mating ring arrangement allows for as much as 0.180" T.I.R. runout (radial shaft movement.) Extend MTBR, preserve batch purity and reduce leakage.

Performance Capabilities

- Temperature: up to 450°F/232°C dry running
up to 500°F/260°C wet running
- Pressure: full vacuum to 500 psi(g)/35 bar(g) wet running
full vacuum to 275 psi(g)/19 bar(g) dry running
- Speed: up to 500 fpm/2.5 m/s dry running
Up to 4700 fpm/23.8 m/s wet running
- End play/axial float allowance: ±0.046"/1.18mm max.
- Shaft runout: 0.180"/4.57mm TIR

Design Features

- Double opposed cartridge arrangement
- Tolerates high levels of shaft displacement, radial deflection, and eccentricity
- Dry running(7700D) and wet running (7700W) versions
- Debris well option
- Radial bearing option

Typical Applications

- For heavy-duty mixer, agitator, and reactor applications.

TYPE 7700D/7700W

DOUBLE OPPOSED CARTRIDGE MIXER SEAL

Type 7700D/7700W Typical Arrangement

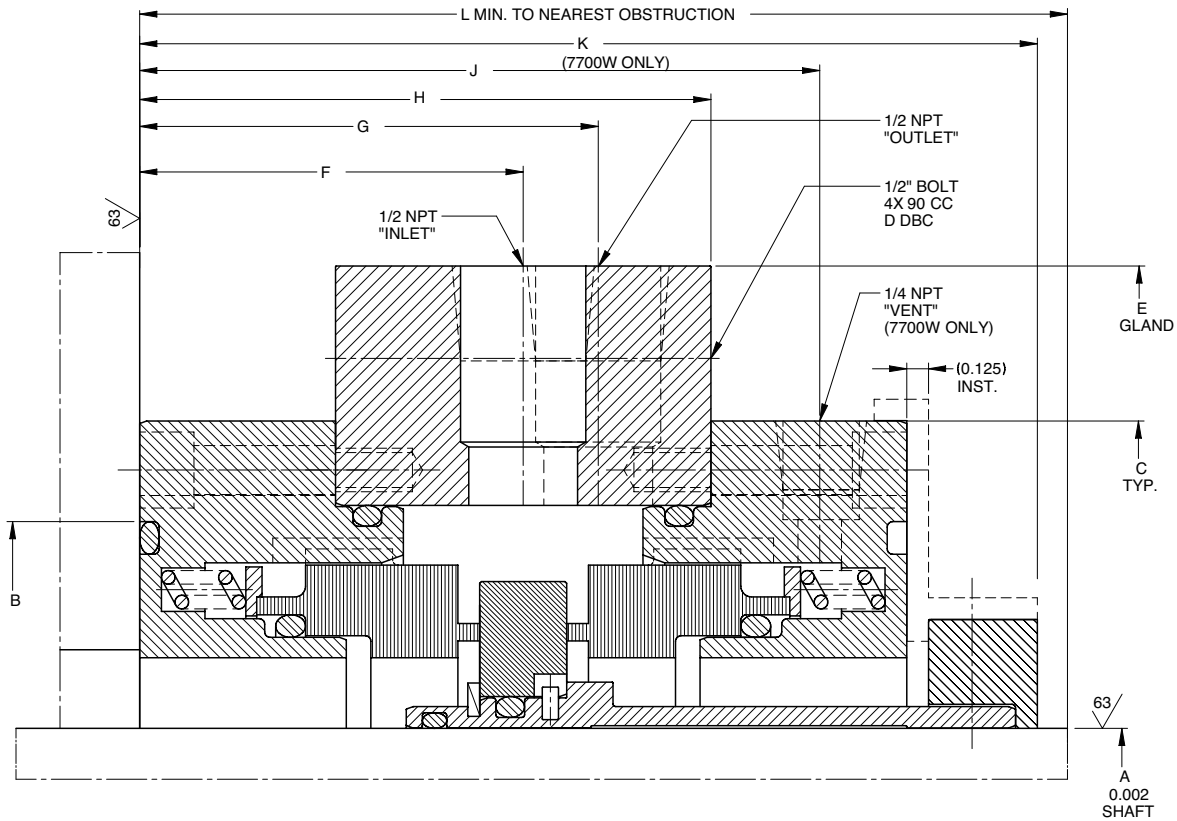

Type 7700D/7700W - Dimensional Data (inches)

Seal Size/A Inch	B	C	D	E	F	G	H	J	K	L
0.750	3.125	4.531	5.250	6.312	1.953	2.484	3.031	3.468	4.656	4.781
1.000	3.375	4.531	5.250	6.312	1.953	2.484	3.031	3.468	4.656	4.781
1.250	3.625	4.781	5.500	6.562	1.953	2.484	3.031	3.468	4.656	4.781
1.500	3.875	5.031	5.750	6.812	1.953	2.484	3.031	3.468	4.656	4.781
1.750	4.125	5.281	6.000	7.062	2.078	2.609	3.156	3.656	4.906	5.031
2.000	4.375	5.531	6.250	7.312	2.078	2.609	3.156	3.656	4.906	5.031
2.250	4.625	5.781	6.500	7.562	2.078	2.609	3.156	3.656	4.906	5.031
2.500	4.875	6.031	6.750	7.812	2.078	2.609	3.156	3.656	4.906	5.031
2.750	5.125	6.281	7.000	8.062	2.203	2.734	3.281	3.906	5.156	5.281
3.000	5.375	6.531	7.250	8.312	2.203	2.734	3.281	3.906	5.156	5.281
3.250	5.625	6.781	7.500	8.562	2.203	2.734	3.281	3.906	5.156	5.281
3.500	5.875	7.031	7.750	8.812	2.203	2.734	3.281	3.906	5.156	5.281
3.750	6.125	7.281	8.000	9.062	2.328	2.859	3.406	4.156	5.406	5.531
4.000	6.375	7.531	8.250	9.312	2.328	2.859	3.406	4.156	5.406	5.531
4.250	6.625	7.781	8.500	9.562	2.328	2.859	3.406	4.156	5.406	5.531
4.500	6.875	8.031	8.750	9.812	2.328	2.859	3.406	4.156	5.406	5.531
4.750	7.125	8.281	9.000	10.062	2.328	2.859	3.406	4.156	5.406	5.531
5.000	7.375	8.531	9.250	10.312	2.328	2.859	3.406	4.156	5.531	5.656
5.250	7.625	8.781	9.500	10.562	2.328	2.859	3.406	4.156	5.531	5.656
5.500	7.875	9.031	9.750	10.812	2.453	2.984	3.531	4.406	5.859	5.984
5.750	8.125	9.281	10.000	11.062	2.453	2.984	3.531	4.406	5.859	5.984
6.000	8.375	9.656	10.375	11.437	2.453	2.984	3.531	4.406	5.859	5.984
6.250	8.625	9.906	10.625	11.687	2.453	2.984	3.531	4.406	5.859	5.984
6.500	8.875	10.156	10.875	11.937	2.671	3.421	3.968	4.843	6.296	6.421
6.750	9.125	10.406	11.125	12.187	2.671	3.421	3.968	4.843	6.296	6.421
7.000	9.375	10.656	11.375	12.437	2.671	3.421	3.968	4.843	6.296	6.421
7.250	9.625	10.906	11.625	12.687	2.671	3.421	3.968	4.843	6.296	6.421
7.500	9.875	11.156	11.875	12.937	2.671	3.421	3.968	4.843	6.296	6.421
7.750	10.125	11.843	12.562	13.625	2.671	3.421	3.968	4.828	6.296	6.421
8.000	10.375	12.093	12.812	13.875	2.671	3.421	3.968	4.828	6.296	6.421
8.250	10.625	12.343	13.062	14.125	2.671	3.421	3.968	4.828	6.296	6.421

TYPE 7700D/7700W

DOUBLE OPPOSED CARTRIDGE MIXER SEAL

Type 7700D/7700W Typical Arrangement

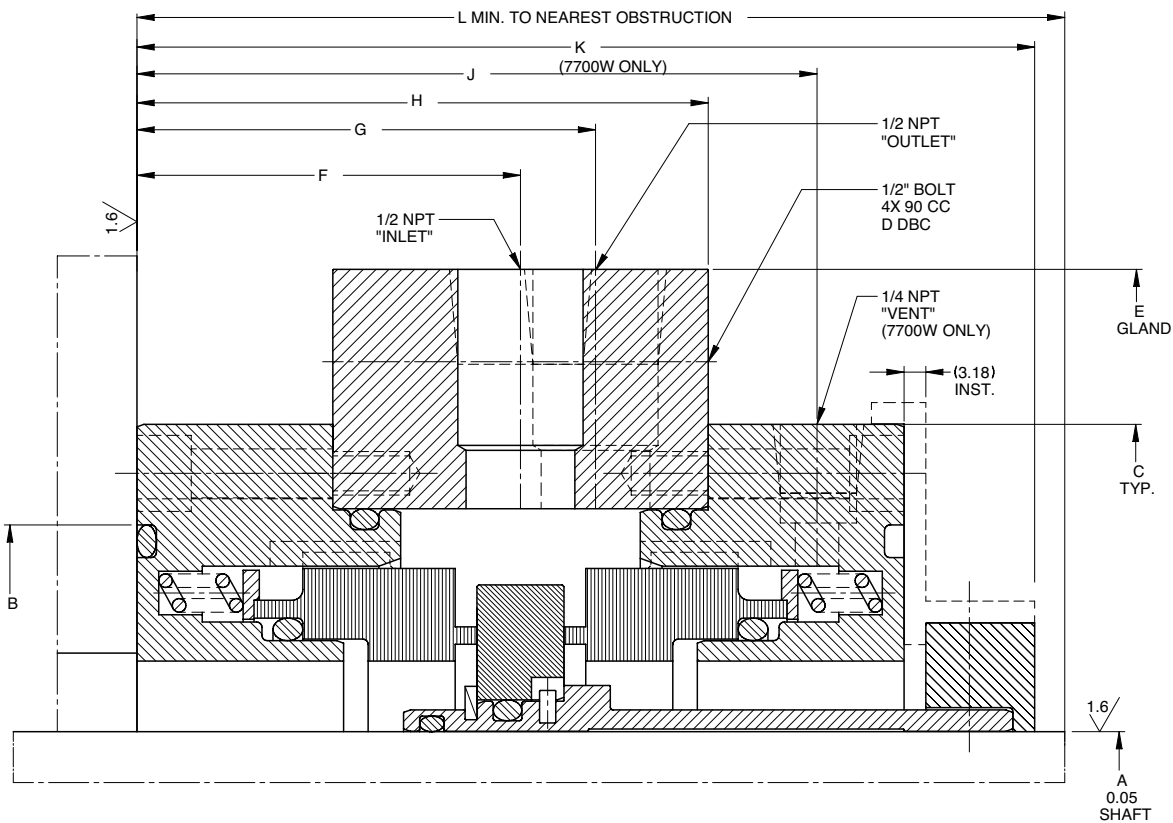

Type 7700D/7700W - Dimensional Data (mm)

Seal Size/A mm	B	C	D	E	F	G	H	J	K	L
19.05	79.38	115.09	133.35	160.32	49.61	63.09	76.99	88.09	118.26	121.44
25.40	85.73	115.09	133.35	160.32	49.61	63.09	76.99	88.09	118.26	121.44
31.75	92.08	121.44	139.70	166.67	49.61	63.09	76.99	88.09	118.26	121.44
38.10	98.43	127.79	146.05	173.02	49.61	63.09	76.99	88.09	118.26	121.44
44.45	104.78	134.14	152.40	179.37	52.78	66.27	80.16	92.86	124.61	127.79
50.80	111.13	140.49	158.75	185.72	52.78	66.27	80.16	92.86	124.61	127.79
57.15	117.48	146.84	165.10	192.07	52.78	66.27	80.16	92.86	124.61	127.79
63.50	123.83	153.19	171.45	198.42	52.78	66.27	80.16	92.86	124.61	127.79
69.85	130.18	159.54	177.80	204.77	55.96	69.44	83.34	99.21	130.96	134.14
76.20	136.53	165.89	184.15	211.12	55.96	69.44	83.34	99.21	130.96	134.14
82.55	142.88	172.24	190.50	217.47	55.96	69.44	83.34	99.21	130.96	134.14
88.90	149.23	178.59	196.85	223.82	55.96	69.44	83.34	99.21	130.96	134.14
95.25	155.58	184.94	203.20	230.17	59.13	72.62	86.51	105.56	137.31	140.49
101.60	161.93	191.29	209.55	236.52	59.13	72.62	86.51	105.56	137.31	140.49
107.95	168.28	197.64	215.90	242.87	59.13	72.62	86.51	105.56	137.31	140.49
114.30	174.63	203.99	222.25	249.22	59.13	72.62	86.51	105.56	137.31	140.49
120.65	180.98	210.34	228.60	255.57	59.13	72.62	86.51	105.56	137.31	140.49
127.00	187.33	216.69	234.95	261.92	59.13	72.62	86.51	105.56	140.49	143.66
133.35	193.68	223.04	241.30	268.27	59.13	72.62	86.51	105.56	140.49	143.66
139.70	200.03	229.39	247.65	274.62	62.31	75.79	89.69	111.91	148.82	151.99
146.05	206.38	235.74	254.00	280.97	62.31	75.79	89.69	111.91	148.82	151.99
152.40	212.73	242.09	260.35	287.32	62.31	75.79	89.69	111.91	148.82	151.99
158.75	219.08	248.44	266.70	293.67	62.31	75.79	89.69	111.91	148.82	151.99
165.10	225.43	254.79	273.05	300.02	67.84	86.89	100.79	123.01	159.92	163.09
171.45	231.78	261.14	279.40	306.37	67.84	86.89	100.79	123.01	159.92	163.09
177.80	238.13	267.49	285.75	312.72	67.84	86.89	100.79	123.01	159.92	163.09
184.15	244.48	273.84	292.10	319.07	67.84	86.89	100.79	123.01	159.92	163.09
190.50	250.83	280.19	298.45	325.42	67.84	86.89	100.79	123.01	159.92	163.09
196.85	257.18	286.54	304.80	331.77	67.84	86.89	100.79	122.63	159.92	163.09
203.20	263.53	292.89	311.15	338.12	67.84	86.89	100.79	122.63	159.92	163.09
209.55	269.88	299.24	317.50	344.47	67.84	86.89	100.79	122.63	159.92	163.09

TYPE 7700D/7700W

DOUBLE OPPOSED CARTRIDGE MIXER SEAL

Technical Specification

Type 7700D/7700W with Debris Well Option

Type 7700D/7700W with Bearing Option

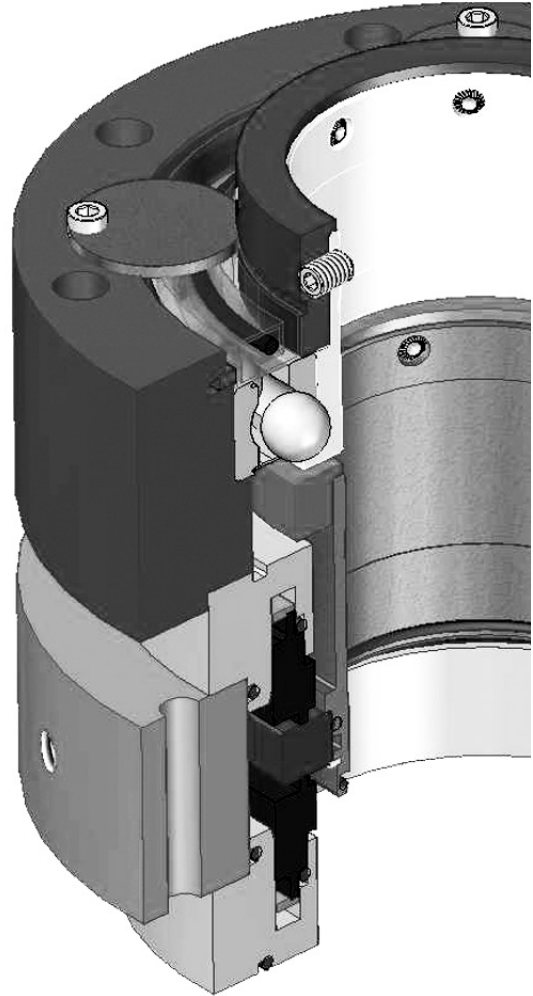
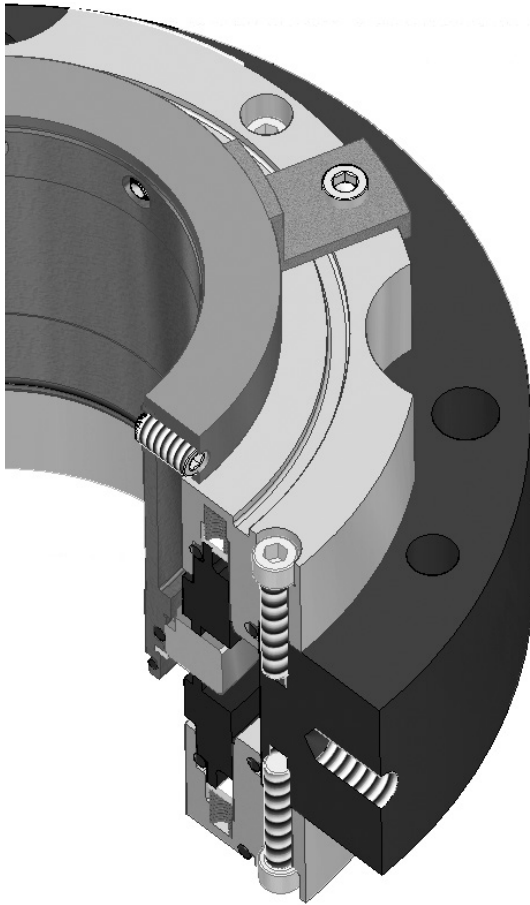

Seal Components

SEAL COMPONENTS	MATERIALS	
	Standard	Options
Description		
Face/Primary Ring	Carbon (Dry-Running) Carbon (Wet-Running)	—
Seat/Mating Ring	Silicon Carbide	Tungsten Carbide
Hardware	316 Stainless Steel	Alloy C-276
O-ring	Fluoroelastomer	Perfluoroelastomer
Spring	316 Stainless Steel	—

TYPE 7700D/7700W

DOUBLE OPPOSED CARTRIDGE MIXER SEAL

Type 7700D Basic Pressure Rating

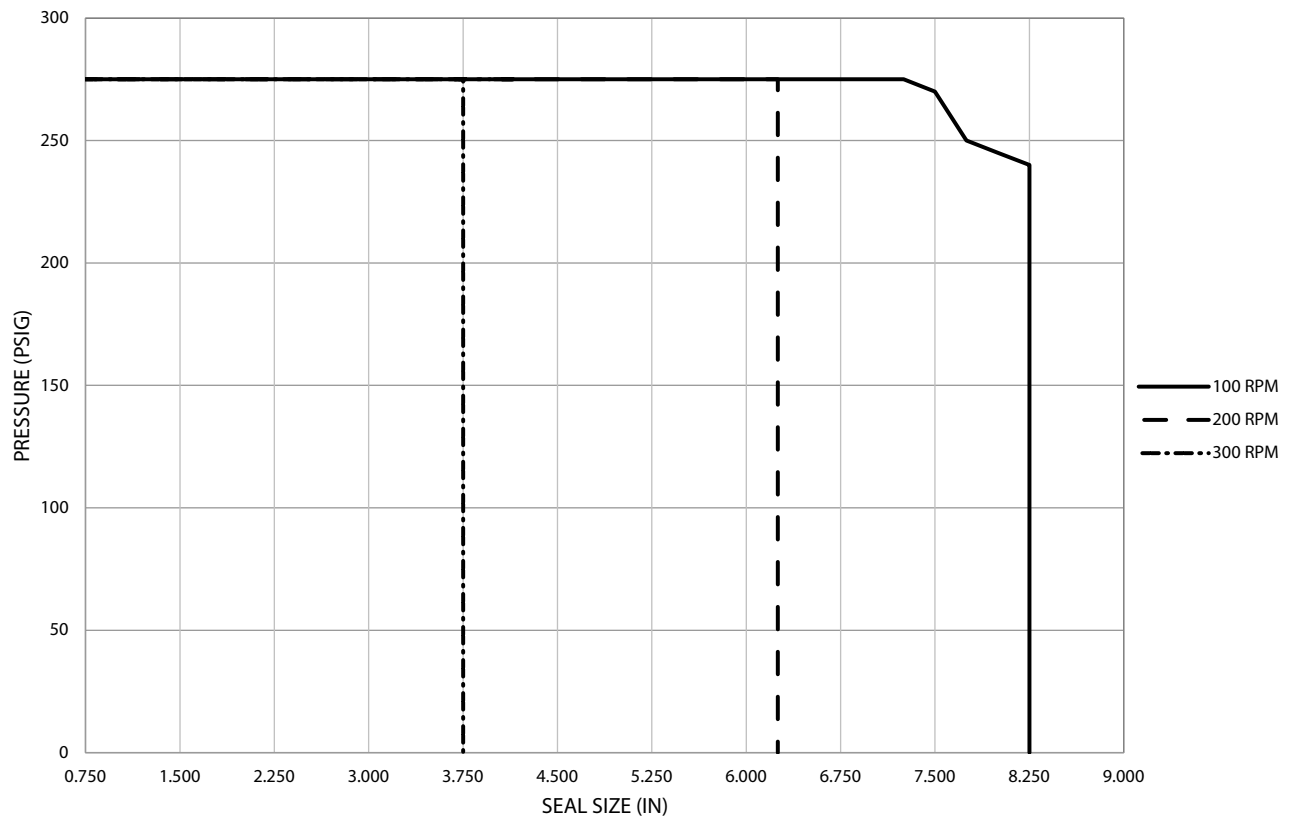

TYPE 7700D/7700W

DOUBLE OPPOSED CARTRIDGE MIXER SEAL

Type 7700W Basic Pressure Rating

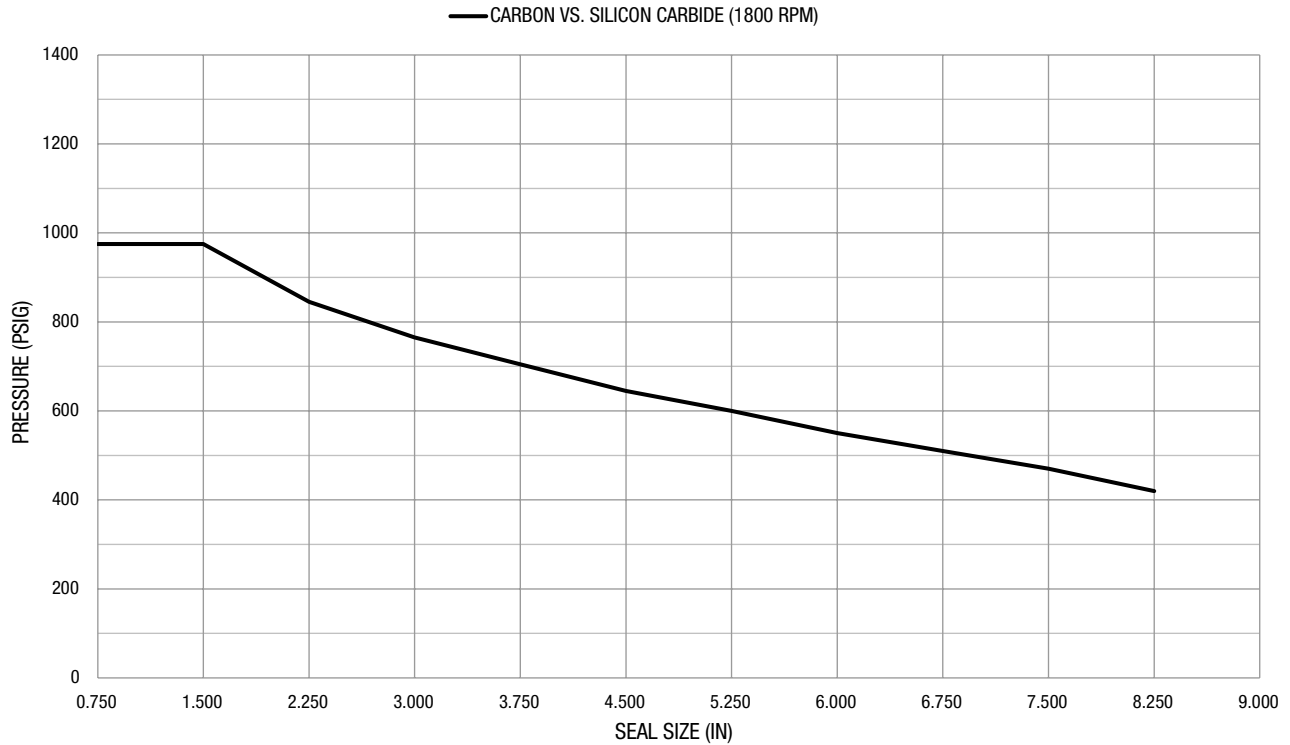

Type 7700W Basic Pressure Considerations

	Selection Considerations	Multiplier Factor
Speed	3600 Rpm **	X 1.00
	Above 3600 Rpm **	***
Sealed Fluid Lubricity	Gasoline, Kerosene, or Better	X 1.00
	Aqueous Solutions	X 0.75
	Hydrocarbons **** [Specific Gravity ≤ 0.65]	X 0.60
Sealed Fluid Temperature	Below 175° F/80° C	X 1.00
	From 175° to 250° F/80° to 125° C	X 0.90
	From 250° to 350° F/125° to 180° C	X 0.80
	Above 350° F/180° C	X 0.65

** Not to exceed 4700 FPM (23.8 m/s)

*** Multiplier = 3600/New Speed

Example: If new speed = 4000 RPM, the multiplier = 3600/4000 = 0.90

**** The ratio of sealed pressure to vapor pressure must be > 1.5

Otherwise, consult John Crane. If the specific gravity is < 0.60, consult John Crane.

Example for Determining Pressure Rating Limits

Seal: 2.000"/50 mm Type 7700W

Product: water

Face material: carbon vs. Silicon carbide

Temperature: 100° F/40° C

Speed: 1800 RPM

Using the basic pressure rating chart, the maximum pressure would be 995 psi(g)/39 bar(g).

From the multiplier factors chart, apply the multipliers for the specific service requirements to determine the maximum operating pressure for the application.

$$995 \text{ psi(g)/39 bar(g)} \times 1.00 \times 0.75 \times 1.00 = 746 \text{ psi(g)/29 bar(g)}$$

At 1800 RPM, with the service conditions noted, a 2.000" (50 mm) Type 7700W seal has a maximum operating limit of 746 psi(g)/29 bar(g).

john crane

TYPE 7700D/7700W

DOUBLE OPPOSED CARTRIDGE MIXER SEAL

Technical Specification



North America
United States of America

Tel: 1-847-967-2400
Fax: 1-847-967-3915

Europe
United Kingdom

Tel: 44-1753-224000
Fax: 44-1753-224224

Latin America
Brazil

Tel: 55-11-3371-2500
Fax: 55-11-3371-2599

Middle East & Africa
United Arab Emirates

Tel: 971-481-27800
Fax: 971-488-62830

Asia Pacific
Singapore

Tel: 65-6518-1800
Fax: 65-6518-1803

If the products featured will be used in a potentially dangerous and/or hazardous process, your John Crane representative should be consulted prior to their selection and use. In the interest of continuous development, John Crane Companies reserve the right to alter designs and specifications without prior notice. It is dangerous to smoke while handling products made from PTFE. Old and new PTFE products must not be incinerated. ISO 9001 and ISO 14001 Certified, details available on request.