

5KSCB2T – for KSB's CPK / CPKN / MegaCPK pump type series

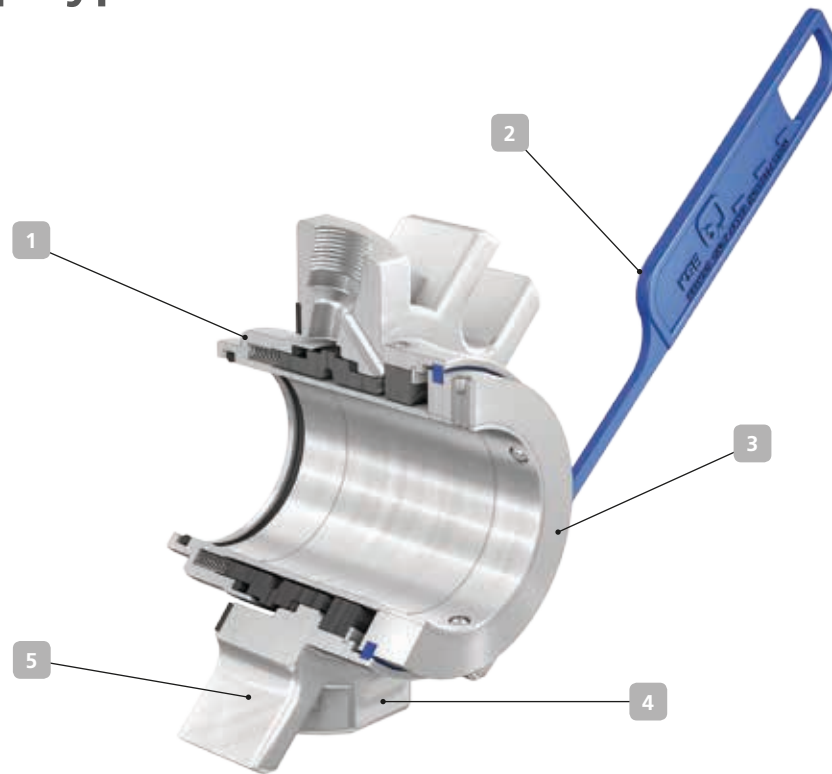

Applications:
chemical and petrochemical industry

1 Compact

The single cartridge seal in quench design makes for easy installation without adjusting dimensions.

2 Service-friendly

A positioning lug ensures optimum pre-loading of the cartridge.

3 Universal

The standard cartridge seal is designed for universal use. It fits perfectly into the installation spaces standardised in the chemical industry, e.g. MegaCPK and CPKN.

4 Versatile

Suitable for all operating conditions the pump is approved for. Available in many material combinations.

5 Interchangeable

The seal can replace other standard cartridge seals such as Burgmann Cartex TN without any modifications.

Materials

Primary ring	SiC (Q1), "B" carbon (B)
Mating ring	SiC (Q1)
Elastomers	PTFE (U1), FFKM (K)
Springs	2.4610 (M)
Other Components	1.4571 (G)

Technical description

Design	Single cartridge seal with quench (throttling bush)
Type	Dynamic, balanced
Springs	Multi-spring arrangement
Direction of rotation	Bi-directional

Technical data

Operating pressure	Up to 25 bar dynamic Up to 37.5 bar static
Temperature	-5 °C to 250 °C
Spring travel	+/- 1 mm
Bearing bracket (seal size)	CS40 (033), CS50 (043), CS60 (053), CS80 (065)
Business type	Standard (KSB EasySelect)

Higher application limits on request