

Product Description Technical Features Operating Range Material

- | | | | |
|---|--|--|---|
| <ul style="list-style-type: none"> ▶ 1,1+1,2-Seal face ▶ 1,3-Drive collar ▶ 1,4-Housing ▶ 1,5-Spring ▶ 1,6-Set screws ▶ 1.7+1.8-O-Ring (For rotary seal) ▶ 2+4-Stationary Seat ▶ 3+5-O-Ring (For stationary seal) | <ul style="list-style-type: none"> ▶ Double seal ▶ Unbalanced ▶ Independent of rotation direction | <ul style="list-style-type: none"> ▶ d1 = 18 - 200mm ▶ p = 16 (25) bar ▶ t = -50 / 220 °C ▶ Vg = 20 m/sn | <ul style="list-style-type: none"> ▶ Rotary seal faces: Carbon, Silicon carbide, Tungsten Carbide, Chromuim Nickle 316 ti ▶ Stationary seal faces: Silicon carbide, Tungsten Carbide, Chromuim Nickle 316 ti, Ceramic ▶ Elastomers : Viton (FKM), EPDM, Nitril (NBR) |
|---|--|--|---|

Stationary Seat Alternatives:

- ▶ G-9 G-13 G-4 G-6

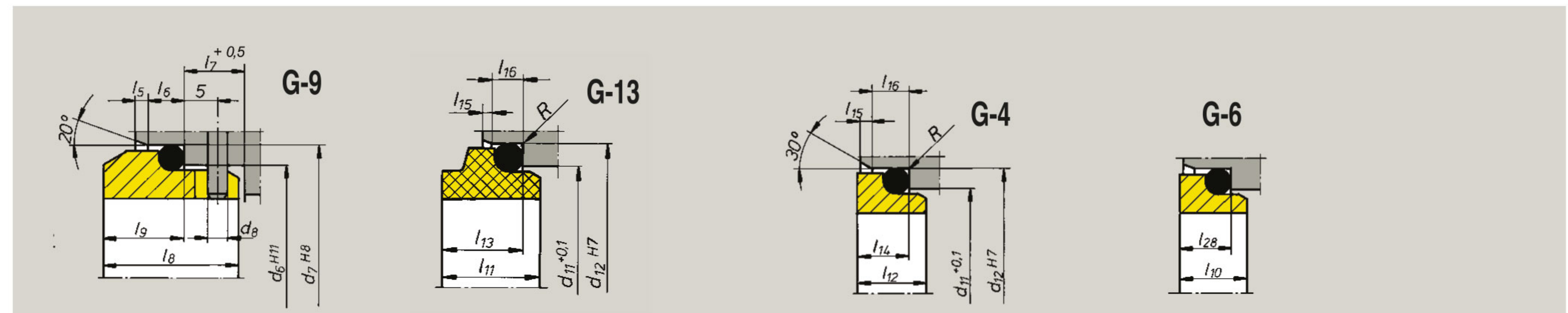

d1	d3	d6	d7	d8	d9	d11	d12	ds	l1	l3	l4	l5	l6	lg	l8	l9	l10	l11	l12	l13	l14	l15	l16	l28	l31	l35	mx	t
18	33	27.0	33.0	3	4	24.0	30.0	-	61.0	38	19.0	2.0	5	9	19.5	11.5	8.5	12.5	9.0	10.0	8.0	1.5	5	7.5	17.0	15	M5	3.5
20	35	29.0	35.0	3	4	29.5	35.0	-	61.0	38	19.0	2.0	5	9	19.5	11.5	8.5	12.5	8.5	9.5	7.5	1.5	5	7.5	17.0	15	M5	3.5
22	37	31.0	37.0	3	4	29.5	35.0	42	61.0	38	19.0	2.0	5	9	19.5	11.5	8.5	12.5	8.5	9.5	7.5	1.5	5	7.5	17.0	15	M5	3.5
24	39	33.0	39.0	3	4	32.0	38.0	44	61.0	38	19.0	2.0	5	9	19.5	11.5	8.5	12.5	8.5	9.5	7.5	1.5	5	7.5	17.0	15	M5	3.5
25	40	34.0	40.0	3	4	32.0	38.0	45	61.0	38	19.0	2.0	5	9	19.5	11.5	8.5	12.5	8.5	9.5	7.5	1.5	5	7.5	17.0	15	M5	3.5
28	43	37.0	43.0	3	4	36.0	42.0	47	62.0	39	19.5	2.0	5	9	19.5	11.5	8.5	14.0	10.0	11.0	9.0	1.5	5	7.5	17.5	15	M6	3.5
30	45	39.0	45.0	3	4	39.2	45.0	49	62.0	39	19.5	2.0	5	9	19.5	11.5	8.5	14.0	11.5	11.0	10.5	1.5	5	7.5	17.5	15	M6	3.5
32	47	42.0	48.0	3	4	42.2	48.0	51	62.0	39	19.5	2.0	5	9	19.5	11.5	8.5	14.0	11.5	11.0	10.5	1.5	5	7.5	17.5	15	M6	3.5
33	48	42.0	48.0	3	4	44.2	50.0	51	62.0	39	19.5	2.0	5	9	19.5	11.5	8.5	14.5	12.0	11.5	10.5	1.5	5	7.5	17.5	15	M6	3.5
35	50	44.0	50.0	3	4	46.2	52.0	54	62.0	39	19.5	2.0	5	9	19.5	11.5	8.5	14.5	12.0	11.5	11.0	1.5	5	7.5	17.5	15	M6	3.5
38	55	49.0	56.0	4	4	49.2	55.0	59	69.0	41	20.5	2.0	6	9	22.0	14.0	10.0	14.5	11.3	11.5	10.3	1.5	5	9.0	18.5	15	M6	3.5
40	57	51.0	58.0	4	4	52.2	58.0	61	70.0	42	21.0	2.0	6	9	22.0	14.0	10.0	14.5	11.8	11.5	10.8	1.5	5	9.0	19.0	15	M6	3.5
43	60	54.0	61.0	4	4	53.3	62.0	65	70.0	42	21.0	2.0	6	9	22.0	14.0	10.0	17.0	13.2	14.3	12.0	2.0	6	9.0	19.0	15	M6	3.5
45	62	56.0	63.0	4	4	55.3	64.0	66	70.0	42	21.0	2.0	6	9	22.0	14.0	10.0	17.0	12.8	14.3	11.6	2.0	6	9.0	19.0	15	M6	3.5
48	65	59.0	66.0	4	4	59.7	68.4	69	70.0	42	21.0	2.0	6	9	22.0	14.0	10.0	17.0	12.8	14.3	11.6	2.0	6	9.0	19.0	15	M6	3.5
50	67	62.0	70.0	4	4	60.8	69.3	71	73.0	43	21.5	2.5	6	9	23.0	15.0	10.5	17.0	12.8	14.3	11.6	2.0	6	9.5	19.5	15	M6	3.5
53	70	65.0	73.0	4	4	63.8	72.3	75	73.0	43	21.5	2.5	6	9	23.0	15.0	12.0	17.0	13.5	14.3	12.3	2.0	6	11.0	19.5	15	M6	3.5
55	72	67.0	75.0	4	4	66.5	75.4	76	73.0	43	21.5	2.5	6	9	23.0	15.0	12.0	18.0	14.5	15.3	13.3	2.0	6	11.0	19.5	15	M8	3.5
58	79	70.0	78.0	4	5	69.5	78.4	83	86.0	56	28.0	2.5	6	9	23.0	15.0	12.0	18.0	14.5	15.3	13.3	2.0	6	11.0	23.5	19	M8	3.5
60	81	72.0	80.0	4	5	71.5	80.4	85	86.0	56	28.0	2.5	6	9	23.0	15.0	12.0	18.0	14.5	15.3	13.3	2.0	6	11.0	23.5	19	M8	3.5
63	84	75.0	83.0	4	5	74.5	83.4	88	85.0	55	27.5	2.5	6	9	23.0	15.0	12.0	18.0	14.2	15.3	13.3	2.0	6	11.0	24.5	19	M8	3.5
65	86	77.0	85.0	4	5	76.5	85.4	95	85.0	55	27.5	2.5	6	9	23.0	15.0	12.0	18.0	14.2	15.3	13.0	2.0	6	11.0	24.5	19	M8	3.5
68	89	81.0	90.0	4	5	82.7	91.5	93	91.0	55	27.5	2.5	7	9	26.0	18.0	12.5	19.0	14.9	16.0	13.7	2.0	6	11.3	24.5	19	M8	3.5
70	91	83.0	92.0	4	5	83.0	92.0	95	92.0	56	28.0	2.5	7	9	26.0	18.0	12.5	18.0	14.2	15.3	13.0	2.0	6	11.3	23.5	19	M8	3.5
75	99	88.0	97.0	4	5	90.2	99.0	105	92.0	56	28.0	2.5	7	9	26.0	18.0	12.5	18.0	15.2	15.3	14.0	2.0	6	11.3	25.5	19	M8	3.5
80	104	95.0	105.0	4	5	95.2	104.0	109	92.5	56	28.0	3.0	7	9	26.2	18.2	13.0	19.0	16.2	16.3	15.0	2.0	6	12.0	25.5	19	M8	3.5
85	109	100.0	110.0	4	5	100.2	109.0	114	92.5	56	28.0	3.0	7	9	26.2	18.2	15.0	19.0	16.0	16.3	14.8	2.0	6	14.0	25.0	19	M8	3.5
90	114	105.0	115.0	4	5	105.2	114.0	119	92.5	56	28.0	3.0	7	9	26.2	18.2	15.0	19.0	16.0	16.3	14.8	2.0	6	14.0	25.5	19	M8	3.5
95	119	110.0	120.0	4	5	111.6	120.3	124	90.5	56	28.0	3.0	7	9	25.2	17.2	15.0	20.0	17.0	17.3	15.8	2.0	6	14.0	25.0	19	M8	3.5
100	124	115.0	125.0	4	5	114.5	123.3	129	90.5	56	28.0	3.0	7	9	25.2	17.2	15.0	20.0	17.0	17.3	15.8	2.0	6	14.0	25.0	19	M8	3.5
105	138	122.2	134.3	5	7	-	-	143	108.0	68	34.0	2.0	10	-	30.0	20.0	-	-	-	-	-	-	-	-	30.5	22	M8	3.5
110	143	128.2	140.3	5	7	-	-	148	110.0	70	35.0	2.0	10	-	30.0	20.0	-	-	-	-	-	-	-	-	31.5	22	M8	3.5
115	148	136.2	148.3	5	7	-	-	153	110.0	70	35.0	2.0	10	-	30.0	20.0	-	-	-	-	-	-	-	-	31.5	22	M8	3.5
120	153	138.2	150.3	5	7	-	-	158	110.0	70	35.0	2.0	10	-	30.0	20.0	-	-	-	-	-	-	-	-	31.5	22	M8	3.5
125	158	142.2	154.3	5	7	-	-	163	110.0	70	35.0	2.0	10	-	30.0	20.0	-	-	-	-	-	-	-	-	31.5	22	M8	3.5
130	163	146.2	158.3	5	7	-	-	168	110.0	70	35.0	2.0	10	-	30.0	20.0	-	-	-	-	-	-	-	-	31.5	22	M8	3.5
135	168	152.2	164.3	5	7	-	-	173	110.0	70	35.0	2.0	10	-	30.0	20.0	-	-	-	-	-	-	-	-	31.5	22	M8	3.5
140	173	156.2	168.3	5	7	-	-	178	110.0	70	35.0	2.0	10	-	30.0	20.0	-	-	-	-	-	-	-	-	31.5	22	M8	3.5
145	178	161.2	173.3	5	7	-	-	183	110.0	70	35.0	2.0	10	-	30.0	20.0	-	-	-	-	-	-	-	-	31.5	22	M8	3.5
150	183	168.2	180.3	5	7	-	-	188	114.0	70	35.0	2.0	10	-	32.0	22.0	-	-	-	-	-	-	-	-	31.5	22	M8	3.5
155	191	173.2	185.3	5	7	-	-	196	127.0	79	39.5	2.0	12	-	34.0	24.0	-	-	-	-	-	-	-	-	35.5	22	M8	3.5
160	196	178.2	190.3	5	7	-	-	201	127.0	79	39.5	2.0	12	-	34.0	24.0	-	-	-	-	-	-	-	-	35.5	22	M8	3.5