

# JAP

autoadescante



## APPLICATIONS



## NOMENCLATURA PARTI DI RICAMBIO SPARE PARTS LIST NOMENCLATURE PIÉCES DE RECHANGE NOMENCLATURA REPUESTOS

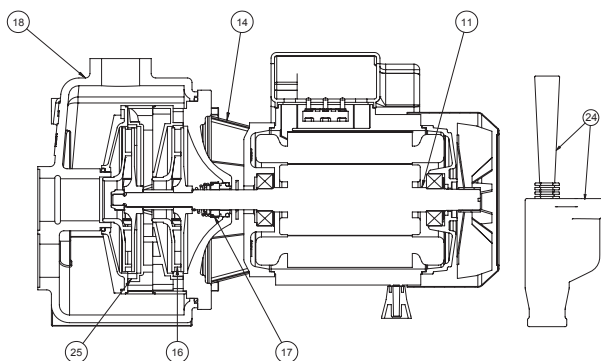
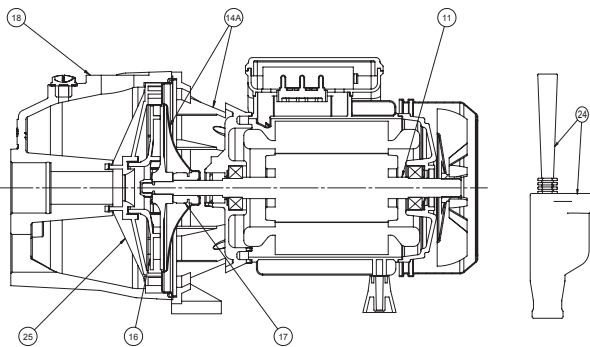

Albero con rotore – Pump shaft + rotor Arbre + rotor – Eje rotor	<b>11</b>
Supporto mandata – Outlet bracket Support envoyée – Soporte entrega	<b>14</b>
Kit supporto – Motor bracket kit Kit support – Kit soporte	<b>14A</b> <b>16</b>
Girante – Impeller Turbine – Impulsor	<b>17</b>
Tenuta meccanica – Mechanical seal Garniture mécanique – Cierre mecánico	<b>18</b>
Corpo pompa – Pump body Corp de pompe – Cuerpo bomba	<b>24</b>
Eiettore completo – Complete ejector Ejecteur complet – Ejector completo	<b>25</b>
Diffusore – Diffuser Diffuseur – Difusor	

### ELETTROPOMPE PER PROFONDA ASPIRAZIONE

Le elettropompe centrifughe autoadescanti per aspirazione profonda serie JAP sono state progettate per pompare acque pulite da pozzi di almeno 4" quando il livello dell'acqua supera gli 8 m di profondità

- Temperatura del liquido fino a 35 °C per uso domestico (CEI EN 60335-2-41) o 60 °C per altri usi e temperatura ambiente fino a 40 °C.
- Portate fino a 3,6 m<sup>3</sup>/h
- Prevalenze fino a 50 m.

### CARATTERISTICHE COSTRUTTIVE

Corpo pompa	Ghisa G20 con trattamento anticorrosione
Supporto motore	Alluminio pressofuso UNI 5076 (ghisa per JAP 150-200)
Eiettore	Ghisa G20 con trattamento anticorrosione
Diffusori, Ugello e Venturi	Tecnopolimero
Giranti	Tecnopolimero
Albero pompa	Acciaio inox AISI 304 (AISI 420 F per JAP 80-100)
Tenuta meccanica	Carbone - Ceramica

### MOTORE

I motori di comando sono del tipo asincrono a gabbia di scoiattolo chiusi, a ventilazione esterna.

- Motoprotettore incorporato e condensatore permanentemente inserito per i tipi monofasi
- La protezione del motore nella versione trifase è a cura del cliente e si raccomandano apparecchiature in accordo con le norme vigenti
- Isolamento classe F
- Servizio S1
- Grado di protezione IP 44
- Protezione morsettiera IP 54

### ÉLECTROPOMPES POUR ASPIRATION EN PROFONDEUR

Les électropompes centrifuges autoamorçantes pour aspiration en profondeur série JAP ont été conçues pour pomper des eaux propres de puits d'au moins 4" quand le niveau de l'eau dépasse les 8 m de profondeur

- Température max. du liquide jusqu'à 35 °C pour utilisation domestique (CEI EN 60335-2-41) ou 60 °C pour d'autres utilisations et température ambiante jusqu'à 40 °C
- Plage d'utilisation jusqu'à 3,6 m<sup>3</sup>/h
- Hauteur manométrique jusqu'à 50 m.

### CARACTERISTIQUES DE CONSTRUCTION

Corps de pompe	En fonte G20 avec traitement anti-corrosion
Lanterne	Fonderie d'aluminium sous pression UNI 5076 (en fonte pour JAP 150-200)
Ejecteur	En fonte G20 avec traitement anti-corrosion
Diffuseurs et groupe venturi	Techonopolymère
Turbine	Techonopolymère
Abre de pompe	Acier inox AISI 304 (AISI 420 F pour JAP 80-100)
Garniture mécanique	Carbone - Céramique

### MOTOR

Les moteurs sont asynchrones à cage d'écureuil fermés à ventilation extérieure monofásicos.

- Pour les modèles monophasés son avec protection thermique et condensateur connecté en permanence
- Pour les modèles triphasés, la protection est à la charge de l'utilisateur. A recommandé l'équipement conformément à la réglementation
- A Classe d'isolation F
- Service S1
- Protection IP44
- Protection IP54 dans le terminal.

### DEEP SUCTION ELECTRIC PUMPS

The self-priming centrifugal deep suction electric pumps series JAP have been designed to pump clean water from wells of at least 4" when the water level is more than 8 m deep

- Liquid temperature not higher than 35 °C for domestic use (CEI EN 60335-2-41) or 60 °C for other use, while the ambient temperature must not be higher than 40 °C
- Flow rate up to 3,6 m<sup>3</sup>/h
- Heads up to 50 m.

### TECHNICAL FEATURES

Pump body	Cast iron G20 with anti-corrosive coating
Motor bracket	In die casting aluminium UNI 5076 (cast iron for JAP 150-200)
Ejector	Cast iron G20 with anti-corrosive coating
Diffusers, Nozzle & Venturi tube	Techno-polymer
Impellers	Polymer
Pump shaft	Stainless steel AISI 304 (AISI 420 F for JAP 80-100)
Mechanical seal	Carbon - Ceramics

### MOTOR

The control motors are asynchronous, squirrel cage-type, closed, with external ventilation

- Incorporated motor protection and capacitor always on, for single-phase models
- The motor protection for three-phase models must be installed by the customer. Equipment compliant with current standards should be used
- Class of insulation F
- Service S1
- Degree of protection IP 44
- Terminal board protection: IP 54

### ELECTROBOMBAS PARA ASPIRACIÓN PROFUNDA

Las electrobombas centrifugas autocebadas para aspiración profunda serie JAP han sido proyectadas para bombear aguas limpias desde pozos de al menos 4" cuando el nivel del agua supera los 8 m de profundidad.

- Temperatura max. del líquido hasta 35 °C para uso doméstico (CEI EN 60335-2-41) o 60 °C para otros usos y temperatura ambiente hasta 40 °C
- Caudal hasta 3,6 m<sup>3</sup>/h
- Alturas hasta 50 m.

### CARACTERÍSTICAS DE CONSTRUCCIÓN

Cuerpo de bomba	Fundición gris G20 con tratamiento contra-corrosión
Soporte	Fundición de aluminio UNI 5076 (Fundición gris G20 para las JAP150-200)
Inyector	Fundición gris G20 con tratamiento contra-corrosión
Difusores y el grupo venturi	Tecnopolímero
Rodetes	Tecnopolímero
Eje de la bomba	Acero Inox AISI304 (AISI 420 F para las JAP 80-100)
Cierre mecánico	Cerámica - Grafito

### MOTOR

Los motores de accionamiento son asíncrono de jaula de ardilla cerrados, ventilados externamente.

- Para los modelos monofásicos, protección térmica y condensador incorporado
- Para los modelos trifásicos se encarga el usuario de la protección del motor y se recomienda un equipo de acuerdo con las normas vigentes
- Aislamiento de Clase F
- Funcionamiento S1
- Protección IP44
- Protección IP54 para el terminal

50 Hz - min<sup>-1</sup> ~ 2900

TIPO TYPE		Potenza nominale Nominal power		Potenza assorbita Input power [W]		Condensatore Capacitor 450 V max	Corrente assorbita Input current [A]			Tipo eiettore Ejector	Aspirazione Suction depth [m]	Portata - Capacity																						
a	b	kW	HP	a	b	[µF]	1~230 V	3~230 V	3~400 V			Q [m <sup>3</sup> /h]	0,2	0,4	0,6	0,9	1,2	1,5	1,8	2,1	3	3,6												
												Q [l/1']	3	6	10	15	20	25	30	35	50	60	Prevalenza (m C.A.) - Total head (m W.C.)											
JAP 80 M	JAP 80 T	0,59	0,8	870	890	14	3,9	2,6	1,5	E20	15	31	28	25	22	19	17	15																
											20	28	25	22	15																			
											25	30	27	18	8																			
											30	28	20	13																				
JAP 100 M	JAP 100 T	0,74	1	930	970	16	4,1	3,1	1,8	E20	15	40	38	36	31	28	24	20																
											20	38	36	32	26	21	17																	
										E30	25			40	32	15																		
											30			38	30																			
											35			33	20																			
																													37	32	25	17		
JAP 150 M	JAP 150 T	1,1	1,5	1800	1910	31,5	7,9	6,1	3,5	E20	15																							
											20																40	30	27	20				
											25																	36	27	25				
										E30	35			52	41	20																		
											40			43	30																			
											50			49	40	15																		
JAP 200 M	JAP 200 T	1,47	2	2340	2100	36	10,3	6,6	3,8	E20	15												43	35										
											20																	43	39	28	23			
											25																		40	31	24	17		
										E30	35																							
											40																							
											50																							

a) ~Monofase 230 V b) ~Trifase 230/400 V

60 Hz - min<sup>-1</sup> ~ 3400

TIPO TYPE		Potenza nominale Nominal power		Potenza assorbita Input power [W]		Condensatore Capacitor 450 V max	Corrente assorbita Input current [A]			Tipo eiettore Ejector	Aspirazione Suction depth [m]	Portata - Capacity																						
a	b	kW	HP	a	b	[µF]	1~220 V	3~220 V	3~380 V			Q [m <sup>3</sup> /h]	0,2	0,4	0,6	0,9	1,2	1,5	1,8	2,1	3	3,6												
												Q [l/1']	3	6	10	15	20	25	30	35	50	60	Prevalenza (m C.A.) - Total head (m W.C.)											
JAP 80 M	JAP 80 T	0,59	0,8	870	890	14	3,9	2,6	1,5	E20	15	31	28	25	22	19	17	15																
											20	28	25	22	15																			
										E30	25	30	27	18	8																			
											30	28	20	13																				
JAP 100 M	JAP 100 T	0,74	1	930	970	20	4,1	3,1	1,8	E20	15	40	38	36	31	28	24	20																
											20	38	36	32	26	21	17																	
										E30	25			40	32	15																		
											30			38	30																			
											35			33	20																			
JAP 150 M	JAP 150 T	1,1	1,5	1800	1910	31,5	7,9	6,1	3,5	E20	15																							
											20																	40	30	27	20			
											25																		36	27	25			
										E30	35			52	41	20																		
											40			43	30																			
											50			49	40	15																		
JAP 200 M	JAP 200 T	1,47	2	2340	2100	40	10,3	6,6	3,8	E20	15												43	35										
											20																		43	39	28	23		
											25																			40	31	24	17	
										E30	35																							
											40																							
											50																							

a) ~Monofase 220 V b) ~Trifase 220/380 V

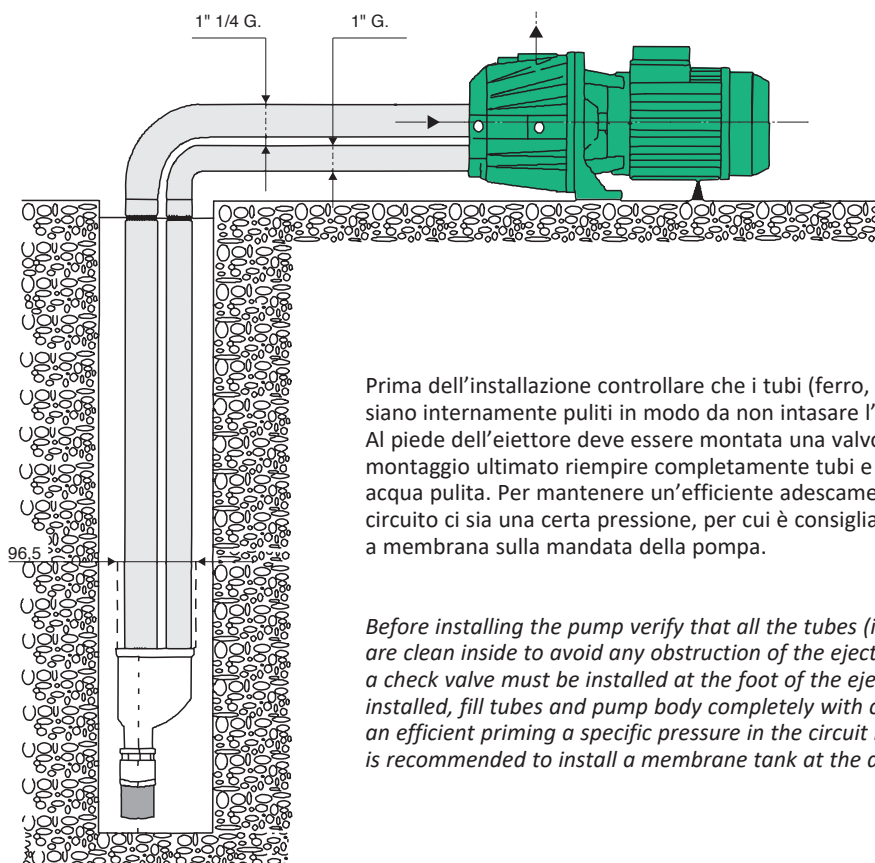

Prima dell'installazione controllare che i tubi (ferro, plastica o gomma) siano internamente puliti in modo da non intasare l'ugello dell'eiettore. Al piede dell'eiettore deve essere montata una valvola di fondo o di ritengo. A montaggio ultimato riempire completamente tubi e corpo pompa con acqua pulita. Per mantenere un'efficiente adescamento è necessario che nel circuito ci sia una certa pressione, per cui è consigliabile montare un serbatoio a membrana sulla mandata della pompa.

*Before installing the pump verify that all the tubes (iron, plastic or rubber) are clean inside to avoid any obstruction of the ejector nozzle. A foot valve or a check valve must be installed at the foot of the ejector. After the pump is installed, fill tubes and pump body completely with clean water. To preserve an efficient priming a specific pressure in the circuit is necessary, therefore it is recommended to install a membrane tank at the delivery of the pump.*

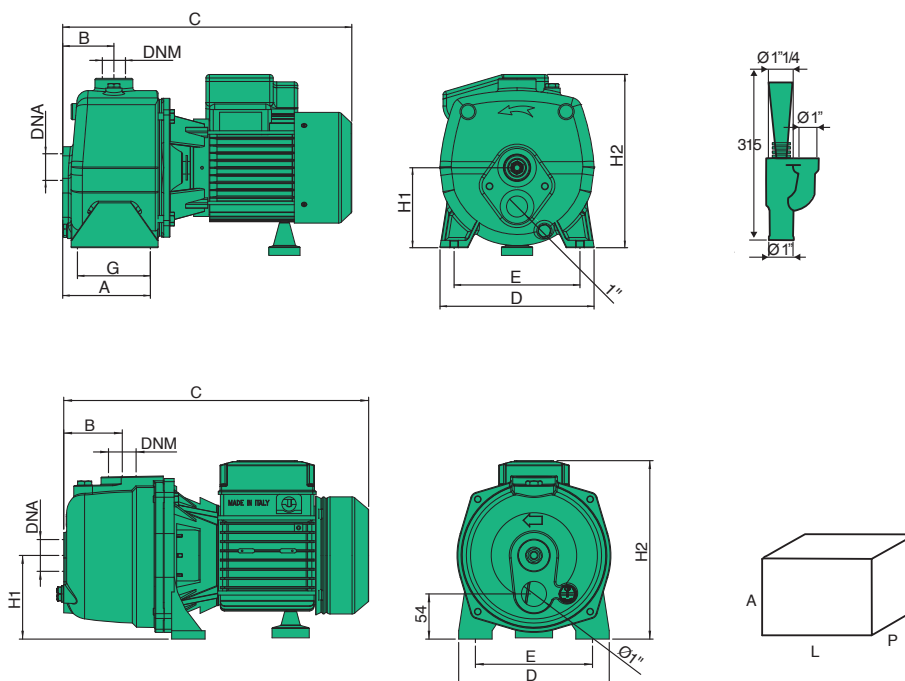

TIPO TYPE	DIMENSIONI [mm] DIMENSIONS [mm]										IMBALLO [mm] PACKING [mm]			PESO WEIGHT [kg]
	A	B	C	D	E	G	H1	H2	DNA	DNM	A	L	P	
JAP 80	160	85	370	180	140	-	100	188	1"1/4	1"	250	450	190	14,2
JAP 100	160	85	370	180	140	-	100	188	1"1/4	1"	250	450	190	16
JAP 150	125	74	415	226	174	104	120	248	1"1/4	1"	350	450	250	26,8
JAP 200	125	74	415	226	174	104	120	248	1"1/4	1"	350	450	250	29,2