

Two impeller centrifugal pumps for constructing pressurisation systems for civil and industrial plant; the two counter-posed impellers guarantee high head and flow rate.

Construction features	
Pump body	cast iron
Motor bracket	cast iron
Impeller	Noryl® or brass (100÷900) brass (800÷1500)
Mechanical seal	ceramic-graphite-NBR
Motor shaft	stainless steel AISI 303 stainless steel AISI 416 (100)
Liquid temperature	Noryl® impeller: 0 - 50 °C brass impeller: 0 - 90 °C
Operating pressure	max 6 bar (100) max 11 bar (160-1500)

Motor	
	3- 230/400V-50Hz P ≤ 4kW 3- 400/690V-50Hz P > 4kW
2 Poles induction motor	1- 230V-50Hz (with thermal protection up to MEC 80)
Insulation class	F
Protection degree	IPX4 IPX5 (800÷1500)

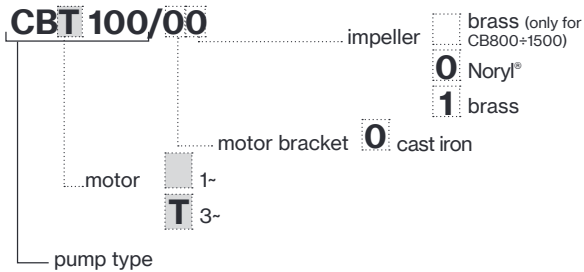

TYPE	LOTS			
	TRUCK		CONTAINER	
	PALLET (cm)	N° pumps	PALLET (cm)	N° pumps
CB 100	90×110×145	65	90×110×195	91
CB 160- CBT 310	85×110×130	40	85×110×190	60
CB 310	85×110×150	24	85×110×180	30
CB 400-900	80×120×150	24	80×120×180	30
CBT 800-1500	100×120×140	18	100×120×185	24

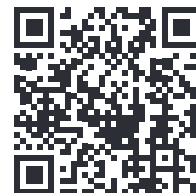

CB

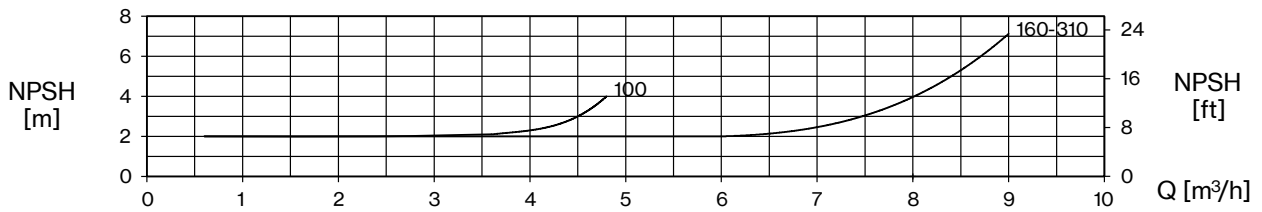
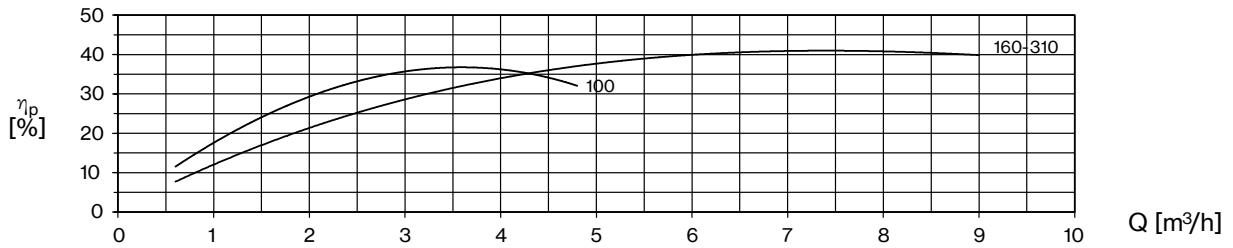
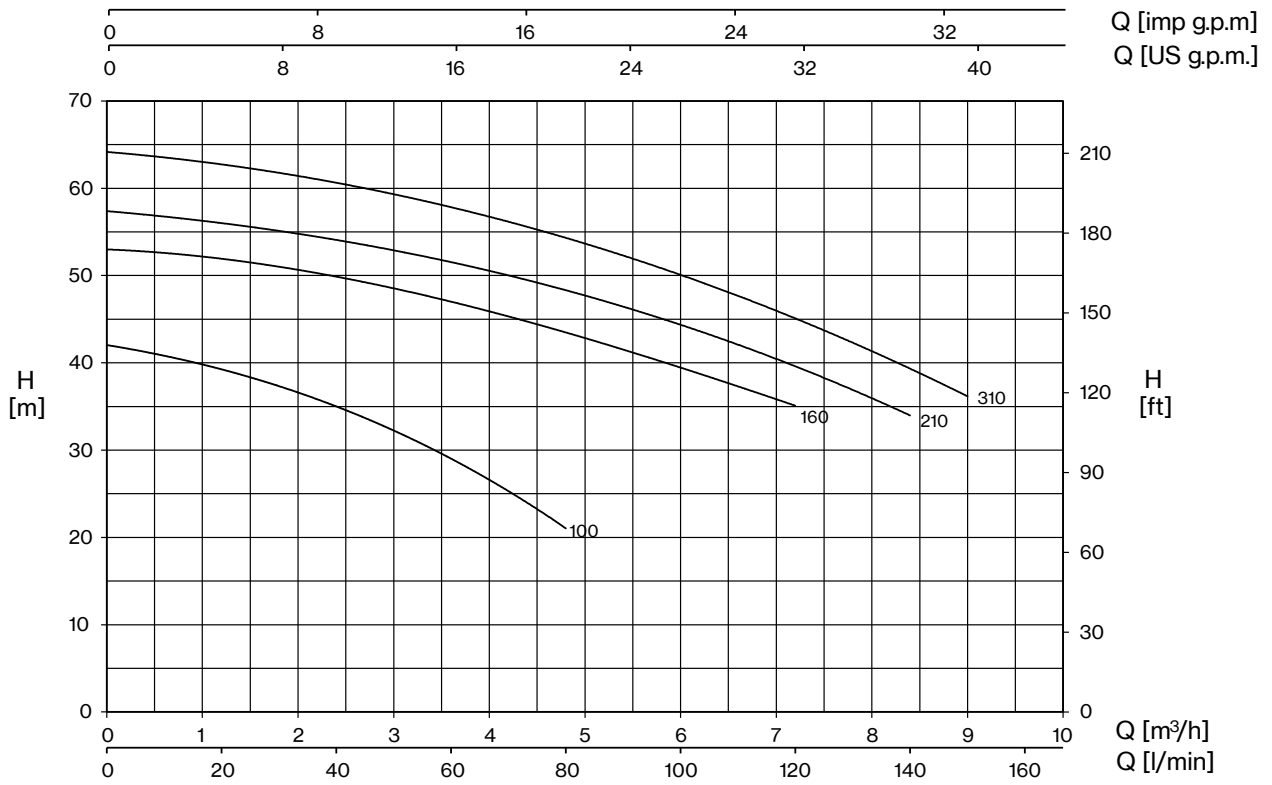

TYPE		P2		P1 (kW)		AMPERE		Q (m³/h - l/min)											
1-	3-	HP	kW	1-	3-	1x230 V 50 Hz	3x400 V 50 Hz	0	0,6	1,2	1,8	2,4	3,6	4,8	6	7,2	8,4	9	
								0	10	20	30	40	60	80	100	120	140	150	
								H (m)											
CB 100	CBT 100	1	0,74	1,17	1,15	5,4	2,4	42,0	40,8	39,4	37,4	34,7	29,2	21,0					
CB 160	CBT 160	1,5	1,1	2,3	2,2	10,2	4,1	53,0	52,5	52,0	51,0	50,0	46,9	43,3	39,7	35,0			
CB 210	CBT 210	2	1,5	2,6	2,45	11,5	4,8	57,3	56,9	56,0	55,1	54,0	51,5	48,4	44,4	39,5	34,0		
CB 310	CBT 310	3	2,2	2,9	2,8	13,2	5,2	64,0	63,5	63,0	61,9	60,6	57,7	54,1	50,0	45,4	39,4	36,0	



CB

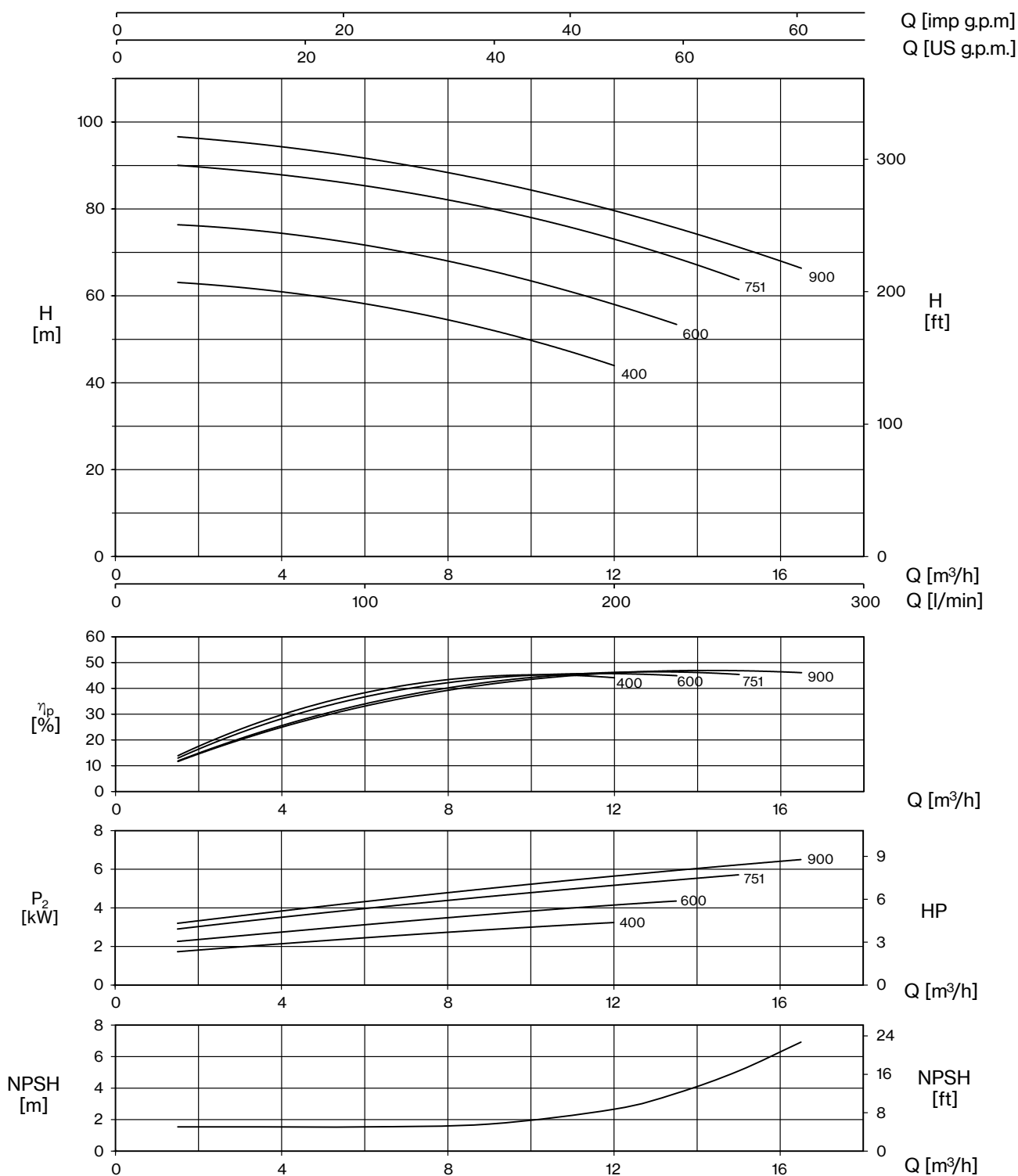

TYPE		P2		P1 (kW)		AMPERE		Q (m³/h - l/min)															
1~	3~					1~	3~	0	1,5	3,0	4,5	6,0	7,5	9,0	10,5	12	13,5	15,0	16,5				
		HP	kW	1~	3~	1x230 V 50 Hz	3x400 V 50 Hz	0	25	50	75	100	125	150	175	200	225	250	275				
								H (m)															
CB 400	CBT 400	4	3,0	3,7	3,8	16,4	6,7	63,6	63,1	62,0	60,3	58,2	55,5	52,3	48,4	43,9							
CB 600	CBT 600	5,5	4,0	5,2	5,0	23,3	9,1	76,9	76,4	75,4	73,8	71,7	69,0	65,9	62,1	58,0	53,4						
-	CBT 751	7,5	5,5	-	6,5	-	11,5	90,7	90,0	88,9	87,3	85,3	82,9	80,1	76,8	73,1	68,8	63,7					
-	CBT 900	10	7,5	-	7,3	-	13,3	97,5	96,6	95,4	93,7	91,7	89,2	86,5	83,3	79,8	75,2	71,2	66,4				



CB

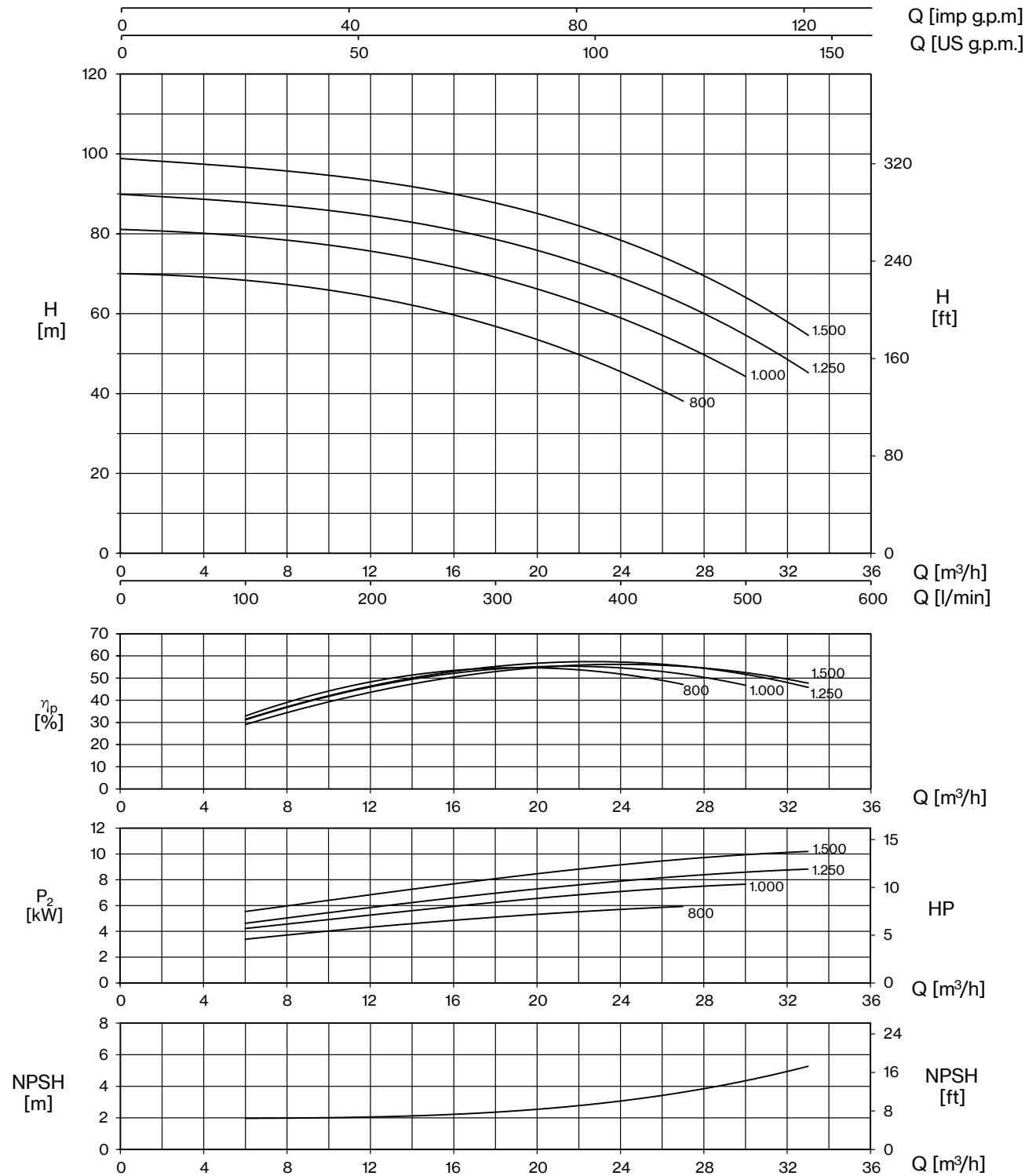

TYPE	P2		P1 (kW)	AMPERE	Q (m³/h - l/min)							
				3~	0	6	12	18	24	27	30	33
	HP	kW	3~	3x400 V 50 Hz	0	100	200	300	400	450	500	550
	H (m)											
CBT 800	7,5	5,5	6,7	11,1	70,0	68,5	63,9	57,1	45,3	38,2		
CBT 1000	10	7,5	8,5	13,9	80,7	80,4	75,0	68,5	59,7	52,6	43,7	
CBT 1250	12,5	9,2	9,8	16,3	89,5	88,8	84,1	77,7	69,7	63,0	54,2	45,1
CBT 1500	15	11,0	11,2	18,6	98,3	97,8	93,5	85,7	78,9	73,3	64,0	54,0



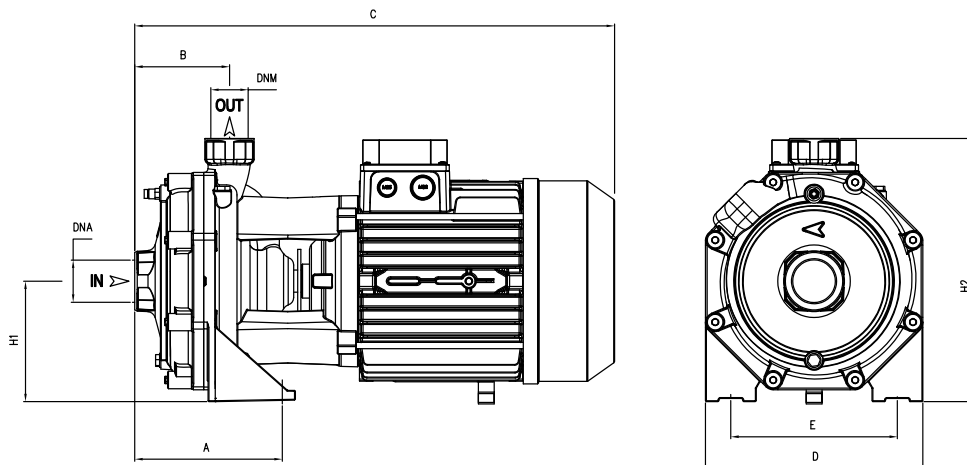

TYPE	DIMENSIONS (mm)													
	A	B	C	D	E	H1	H2	DNA	DNM	I	L	M	kg	T
CB 100	122	72	328	180	140	98	228	1" G	1" G	350	195	265	15,5	T 15
CB 160	115	82	385	210	170	110	265	1" ¼ G		405	225	295	23,5	T 22,5
CB 210	115	82	385	210	170	110	265		1" ¼ G	405	225	295	24,5	T 23,5
CB 310	115	82	385	210	170	110	265	1" ½ G		405	225	295	29,5	T 24,5
CB 400	145	95,5	498	266	212	135	305		1" ½ G	553	274	318	48	T 44
CB 600	145	95,5	498	266	212	135	305	1" ½ G		553	274	318	56,5	T 48
CBT 751	145	95,5	532	266	212	135	305		2" G	553	274	318	56	
CBT 900	145	95,5	532	266	212	135	305	2" G		553	274	318	62	
CBT 800	190	120	605	275	210	150	330		2" G	722	290	370	78	
CBT 1000	190	120	605	275	210	150	330	2" G		722	290	370	84	
CBT 1250	190	120	645	275	210	150	330		2" G	722	290	370	91,5	
CBT 1500	190	120	645	275	210	150	330	2" G		722	290	370	95,5	