



PA 106



PA 200 T



4"



Self-priming centrifugal pump with external ejector (convertible) 2" and 4"; for water supplies (even if mixed with gas) in small household systems, when connected to autoclave tanks, an automatic pressurisation system comes.

### Construction features

<b>Pump body</b>	cast iron
<b>Motor bracket</b>	aluminum (80÷100), cast iron (150÷200)
<b>Impeller</b>	Noryl® or brass
<b>Mechanical seal</b>	ceramic-graphite-NBR
<b>Motor shaft</b>	steel AISI 416 (80÷100), steel AISI 303 hydraulic part (150÷200)
<b>Liquid temperature</b>	0 - 50 °C
<b>Operating pressure</b>	max 8 bar

### Motor

	3- 230/400V-50Hz
<b>2 poles induction motor</b>	1- 230V-50Hz (with thermal protection)
<b>Insulation class</b>	F
<b>Protection degree</b>	IPX4

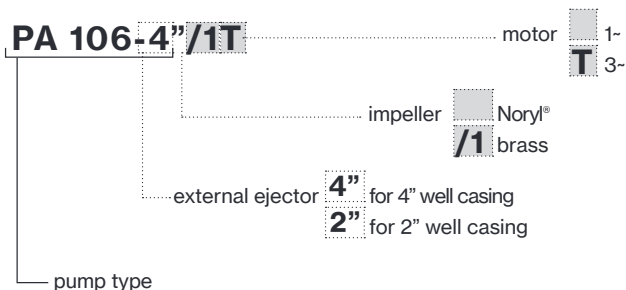

TYPE	LOTS			
	TRUCK		CONTAINER	
	PALLET (cm)	N° pumps	PALLET (cm)	N° pumps
PA 86-106	85×110×145	60	85×110×190	80
PA 150-200	80×120×140	35	80×120×190	49

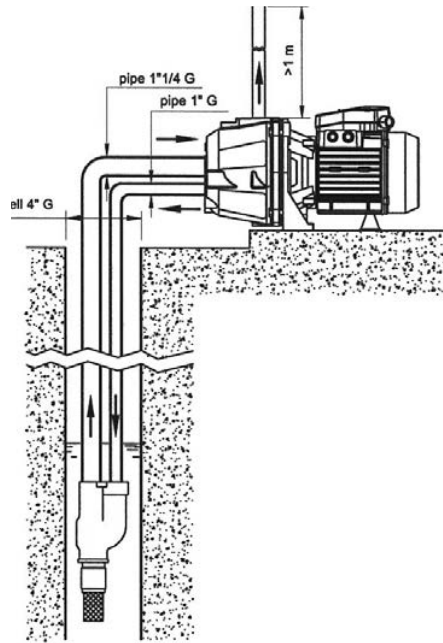

TYPE		P2		P1 (kW)		AMPERE		Ejector type	Suction depth. m	Q (m³/h - l/min)															
1~	3~	HP	kW	1~	3~	1~ 50 Hz	3~ 50 Hz			H (m)															
										0,18 3	0,36 6	0,6 10	0,9 15	1,2 20	1,5 25	1,8 30	2,1 35	3 50	3,6 60						
PA 86	PA 86 T	0,8	0,59	0,8	0,81	3,7	1,4	P 20	15	31	28	25	22	19	17	15	12								
								P 30	20	28	23	18	15	13	11										
PA 106	PA 106 T	1	0,74	1,02	1,05	4,7	2,3	P 20	25	22	16	11	8												
								P 30	30	14	8														
								P 20	15	40	37	34	30	27	24	21	18								
PA 150	PA 150 T	1,5	1,1	1,65	1,65	8,2	3	P 30	20	37	34	30	25	21	17										
								P 20	25	30	25	20	14	11											
								P 30	30	14	8														
								P 20	35	12	4														
PA 200	PA 200 T	2	1,5	2,22	2,22	10,3	4,1	P 20	15							42	35	25	21						
								P 30	20																
								P 20	25																
PA 200	PA 200 T	2	1,5	2,22	2,22	10,3	4,1	P 30	35			49	48	41	20										
								P 20	40																
								P 30	50			49	43	20											
								P 20	15																
PA 200	PA 200 T	2	1,5	2,22	2,22	10,3	4,1	P 20	20							48	43	32	27						
								P 30	25																
								P 30	35																
PA 200	PA 200 T	2	1,5	2,22	2,22	10,3	4,1	P 20	40				46	30		28	20								
								P 30	50			49	40												

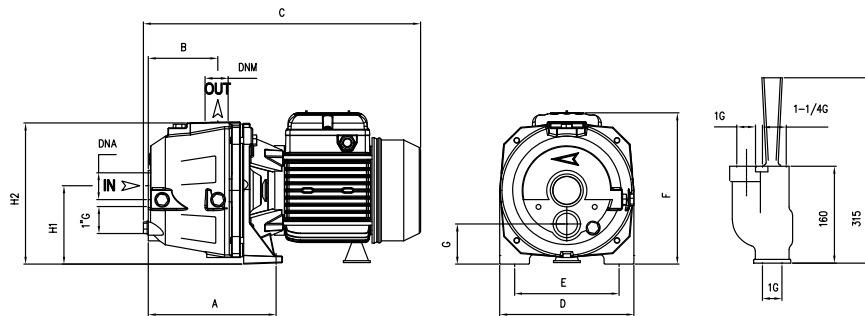

TYPE	DIMENSIONS (mm)											M			Kg
	A	B	C	D	E	F	G	H1	H2	DNA	DNM	I	L	M	
PA 86	168	82	360	180	140	195	52	97	188			440	200	225	16
PA 106	168	82	360	180	140	195	52	97	188	1" 1/4 G	1" G	440	200	225	18
PA 150	125	74	415	220	177	230	60	112	240			525	230	280	28,5
PA 200	125	74	415	220	177	230	60	112	240			525	230	280	29