

End Suction Norm Centrifugal Pumps with Magnetic Coupling

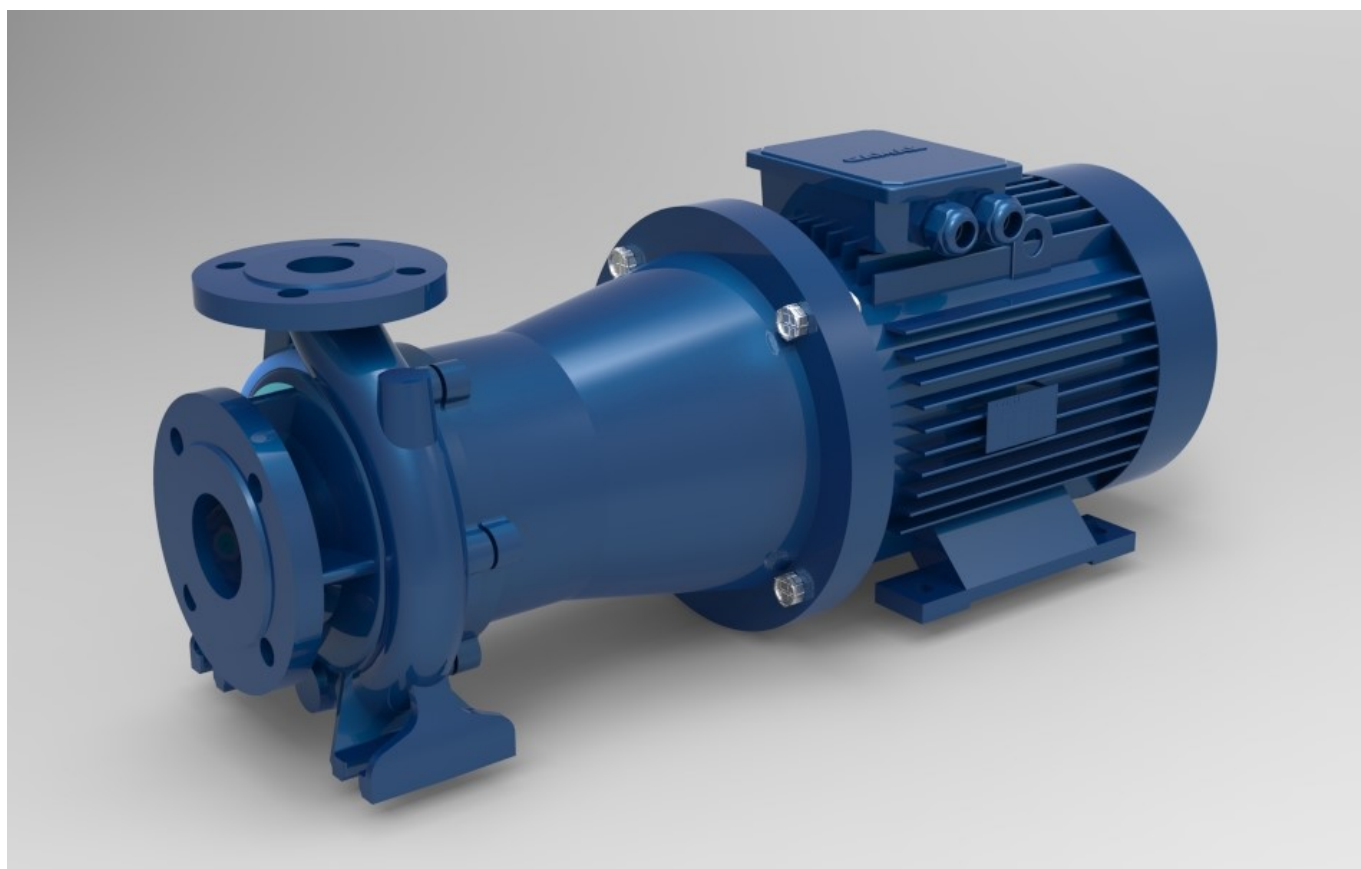

TECHNICAL MANUAL



Mas Grup



NM mDrive Series

End Suction Norm Centrifugal Pumps with Magnetic Coupling

General Information



Mas Grup

Fields of Application

- Transfer of corrosive, explosive, burnable, toxic, valuable, volatile and hot liquids.
- Chemical and petrochemical industries
- Detergents known as dangerous fluid in food facilities
- Harmful gas cleaning systems
- Biodiesel facilities
- Heating and cooling systems
- Power stations
- Solar energy systems
- Medical industries
- Electrostatic applications of powdered paint
- Cooling systems of carbon arc furnace

Handled Liquids

They can be used in pressurizing of toxic, burnable, explosive and dangerous liquids or valuable, volatile liquids and the liquids which they must not be mixed with external substances or hot liquids (up to 300 °C).

Please contact **MAS DAF MAKINA SANAYI A.Ş.** for special applications.

Design

- NM mDrive series pumps are single stage, end suction, seal-less volute type pumps with magnetic coupling.
- Single entry, closed impeller is hydraulically thrust compensated and dynamically balanced.
- Main dimensions according to EN 733.
- Pump and motor are connected to each other on a base plate by using magnetic coupling.
- Pump can be dismantled without removing pump casing thus maintenance and assembly operations can be easily performed.

Bearings

Silicium carbide plain bearings which are lubricated by process fluid are used in NM mDrive series pump.

Shaft Seal

Thanks to magnetic couplings which are used in NM mDrive series pumps, zero leakage is provided. Outer magnetic rotor is rotated by motor shaft and inner magnetic rotor is rotated synchronously to outer magnetic rotor by magnetic forces without any physical contact. Inside of the pump is isolated from environment by containment shroud and zero leakage is guaranteed.

Technical Data

- Suction Flange : DN 50... DN 100
- Discharge Flange : DN 32...DN 80
- Operating Pressure : 10 Bar
- Casing Test Pressure : 14 Bar
- Operating Temperature : Up to 300°C
- Impeller Diameter Range : 120-218 mm \varnothing
- Speed Range : 1000 – 2900 rpm
- Capacity Range : 10 – 200 m³ / h
- Head Range : 4 - 65 m
- Maximum Power : 18.5 kW

Pump Flanges

- Discharge Flange : DIN 2533 PN 16
- Suction Flange : DIN 2533 PN 16

Identification Code

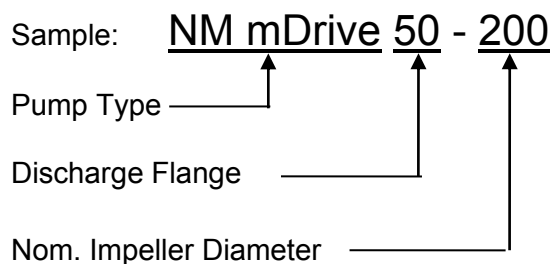

NM mDrive Series

End Suction Norm Centrifugal Pumps with Magnetic Coupling

Performance Range



Mas Grup

NM M-Drive 1450 rpm

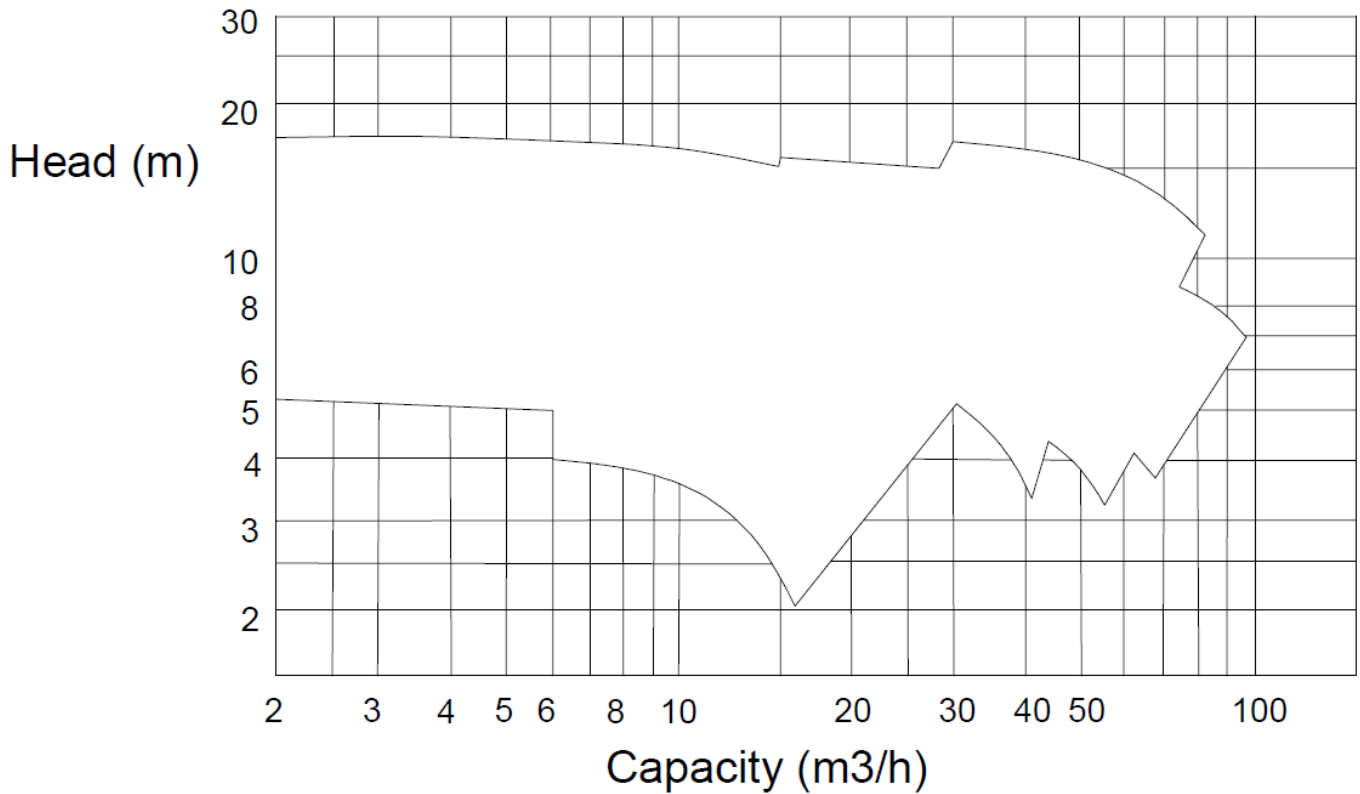

NM M-Drive 2900 rpm

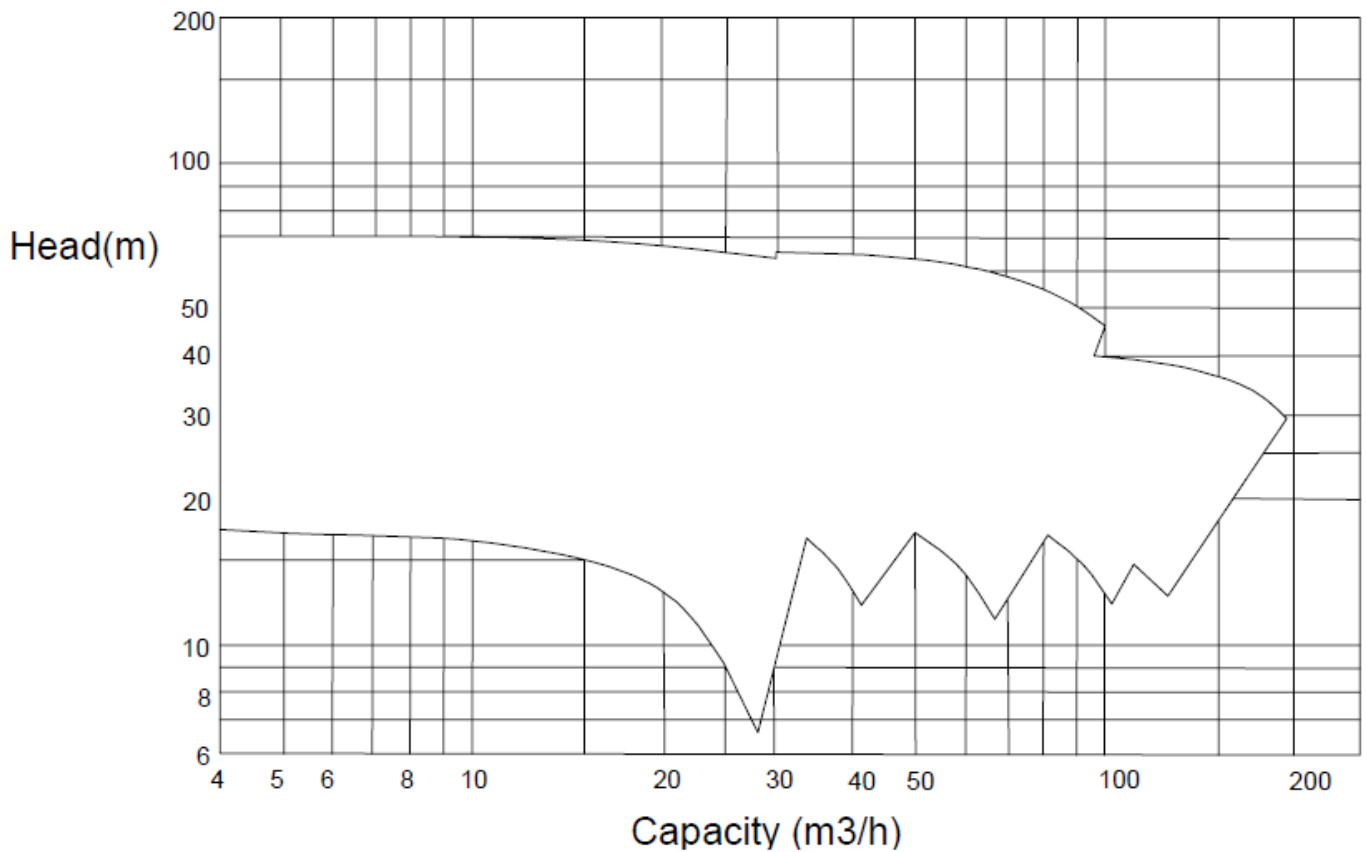

NM mDrive Serisi

End Suction Norm Centrifugal Pumps with Magnetic Coupling

Cross-Sectional View of End Suction Centrifugal Pump



Mas Grup

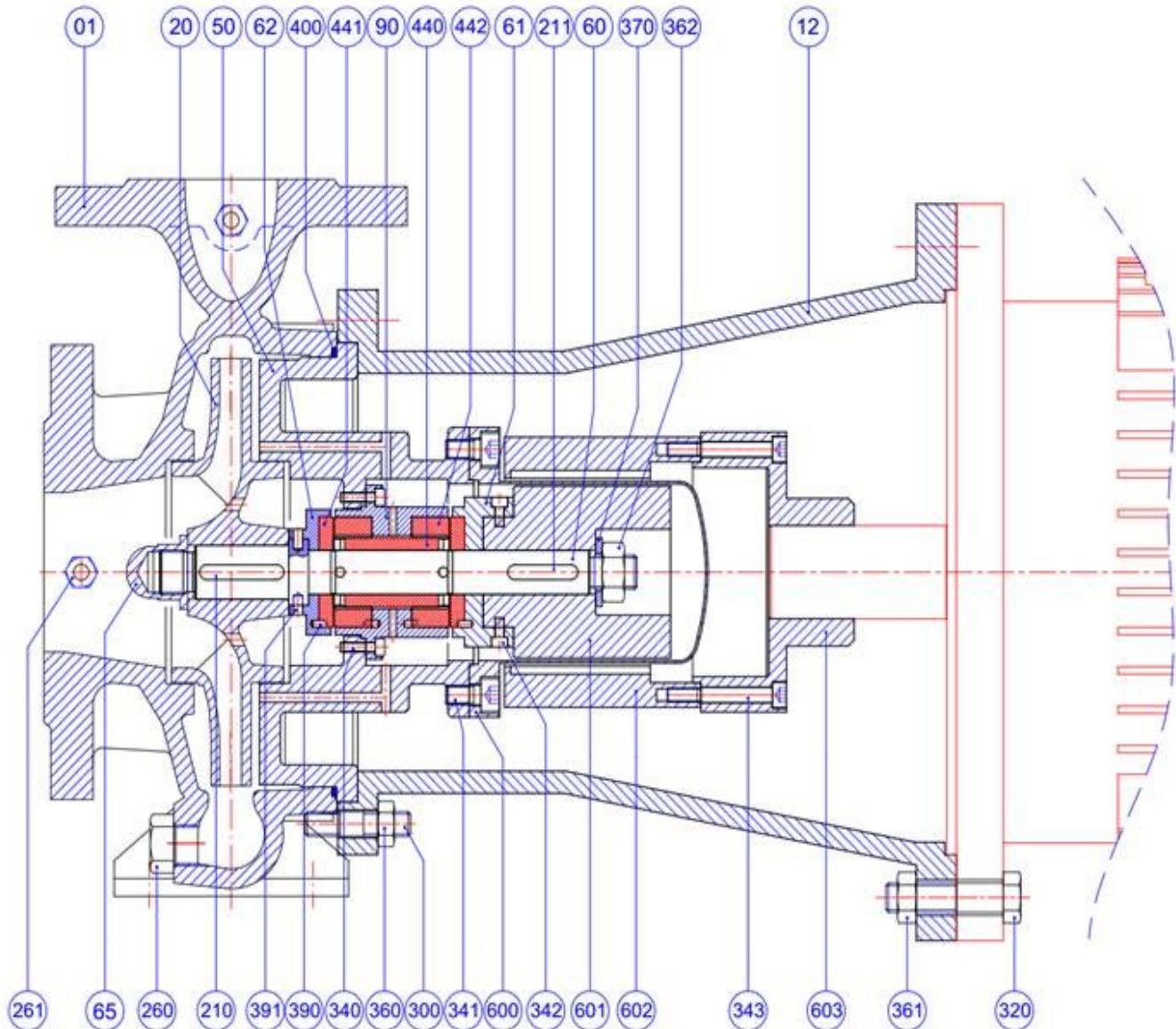

PART NO	PART NAME	PART NO	PART NAME
01	Volute Casing	342	Imbues Bolt
12	Adapter	343	Imbues Bolt
20	Impeller	360	Nut
50	Main Bearing Housing	361	Nut
60	Shaft	362	Bearing Adjustment Nut
61	Axial Back Bearing Casing	370	Bearing Adjustment Nut Washer
62	Axial Front Bearing Casing	390	Pin
65	Impeller Nut	391	Pin
90	Radial Bearing Casing	400	O-Ring
210	Impeller Key	440	SiC Radial Bearing Sleeve
211	Coupling Key	441	SiC Axial Bearing
260	Plug	442	SiC Radial Bearing Bushing
261	Plug	600	Containment Shroud
300	Stud (Casing)	601	Inner Magnetic Rotor
320	Bolt	602	Outer Magnetic Rotor
340	Imbues Bolt	603	Motor Connection Part
341	Imbues Bolt		

NM mDrive Series

End Suction Norm Centrifugal Pumps with Magnetic Coupling

Technical Information



Mas Grup

Temperature and Pressure Limits

Casing Material	Max. Fluid Temperature	Max. Casing Pressure
Stainless Steel AISI 304-316	300°C	10 bar

Material Options

Part	Material						
		0.6025	0.7040	2.1050.01	1.4021	1.4301	1.4401
Volute Casing		o	o	o		•	o
Impeller		o	o	o		•	o
Shaft					o	•	o
Bearing Housing						•	
Adapter		•					

Material Equivalent

Description	DIN 17007	EN-DIN	ASTM
Cast Iron	0.6025	GJL-250 (GG25)	A 48 Class 40-B
Nodular Cast Iron	0.7040	GJS-400-15 (GGG40)	A 536 Gr.60-40-18
Cast bronze	2.1050.01	G-Cu Sn 10	B 584 C 90700
Chrome Steel	1.4021	X20 Cr 13	A 276 Type 420
Chrome Nickel Steel	1.4301	X5 Cr Ni 18.9	A 276 Type 304
Chrome Nickel Molybdenum Steel	1.4401	X5 Cr Ni Mo 18.10	A 276 Type 316

*Wearing Rings and Shaft Sleeves are upon request.

Key-Way and Shaft Dimensions for Motor Side

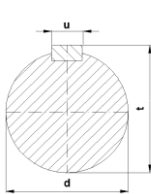

Group	d	t	u
A	24	28	8

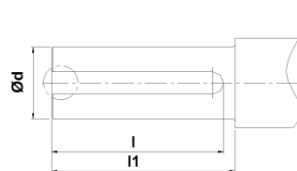

l	l1
50	47

Key-Way and Shaft Dimensions for Impeller Side

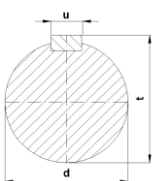

Group	d	t	u
A	22	26	6

Pump Suction and Discharge Flange Dimensions

DNs	PN	ØD	Øk	Ød4	Ød2	b	f	Hole Quantity
32	16	140	100	78	18	18	2	4
40		150	110	88	18	18	3	4
50		165	125	102	18	20	3	4
65		185	145	122	18	20	3	4
80		200	160	138	18	22	3	8
100		220	180	158	18	24	3	8

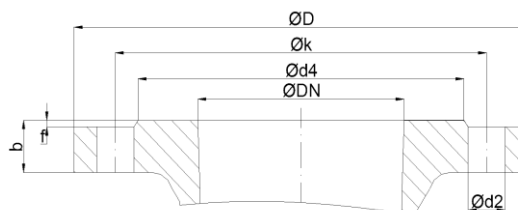

No	Pump Type	Flange				
		DNs (mm) Suction		DNd (mm) Discharge		
1	32-160	50	PN 16	PN 16	32	
2	32-200					
3	40-160	65				40
4	40-200					
5	50-160	65				5
6	50-200					
7	65-160	80				65
8	65-200					
9	65-250					
10	80-160					
11	80-250	100				80

NM mDrive Serisi

End Suction Norm Centrifugal Pumps with Magnetic Coupling

General Dimensions



Mas Grup

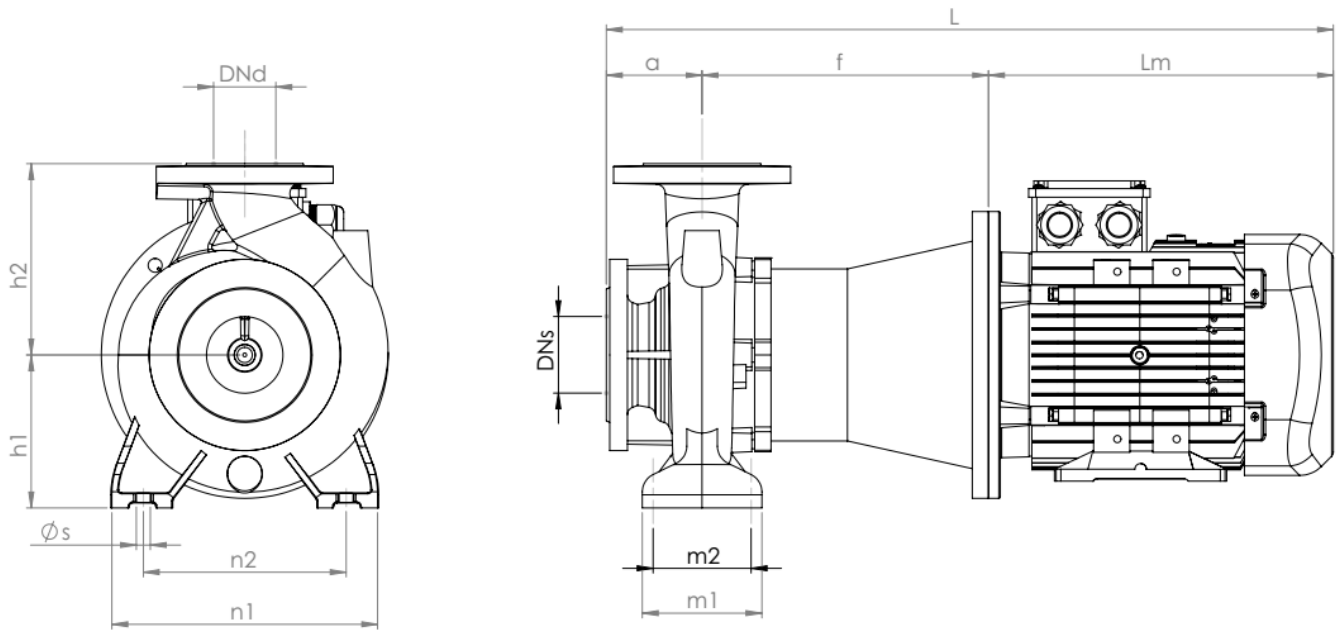

PUMP TYPE	MOTOR			FLANGES		GENERAL	PUMP									
	KW	IEC	Lm mm	DNd mm	DNs mm	L mm	a mm	f mm	h1 mm	h2 mm	n1 Mm	n2 mm	m1 mm	m2 mm	s mm	
32-160	1450 rpm	0.55	80	243.5	32	50	597.5	80	274	132	160	240	190	100	70	12
		0.75	80	243.5			597.5		274							
	2900 rpm	1.5	90L	266.5			626	80	279.5							
		2.2	90L	266.5			626		279.5							
		3	100L	292			656.5		284.5							
		4	112M	335.5			700		284.5							
5.5	132S	360.5	750	309.5												
32-200	1450 rpm	0.55	80	243.5	32	50	597.5	80	274	160	180	240	190	100	70	12
		0.75	80	243.5			597.5		274							
		1.1	90L	266.5			626		279.5							
		1.5	90L	266.5			626		279.5							
	2900 rpm	4	112M	335.5			700	80	284.5							
		5.5	132S	360.5			735.5		295							
		7.5	132M	395.5			770.5		295							
		11	160M	666			475		345							
40-160	1450 rpm	0.55	80	243.5	40	65	597.5	80	274	132	160	240	190	100	70	12
		0.75	80	243.5			597.5		274							
	2900 rpm	3	100L	292			656.5	80	284.5							
		4	112M	335.5			700		284.5							
		5.5	132S	360.5			750		309.5							
		7.5	132M	395.5			785		309.5							
40-200	1450 rpm	0.55	80	243.5	40	65	617.5	100	274	160	180	265	212	100	70	12
		0.75	80	243.5			617.5		274							
		1.1	90L	266.5			646		279.5							
		1.5	90L	266.5			646		279.5							
	2900 rpm	5.5	132S	360.5			755.5	100	295							
		7.5	132M	395.5			790.5		295							
		11	160M	666			1111		345							
		15	160L	666			1111		345							
50-160	1450 rpm	0.75	80	243.5	50	65	617.5	100	274	160	180	265	212	100	70	12
		1.1	90L	266.5			646		279.5							
		1.5	90L	266.5			646		279.5							
	2900 rpm	4	112M	335.5			720	100	284.5							
		5.5	132S	360.5			770		309.5							
		7.5	132M	395.5			805		309.5							
		11	160M	666			1111		345							
		15	160L	666			1111		345							

NM mDrive Serisi

End Suction Norm Centrifugal Pumps with Magnetic Coupling

General Dimensions



Mas Grup

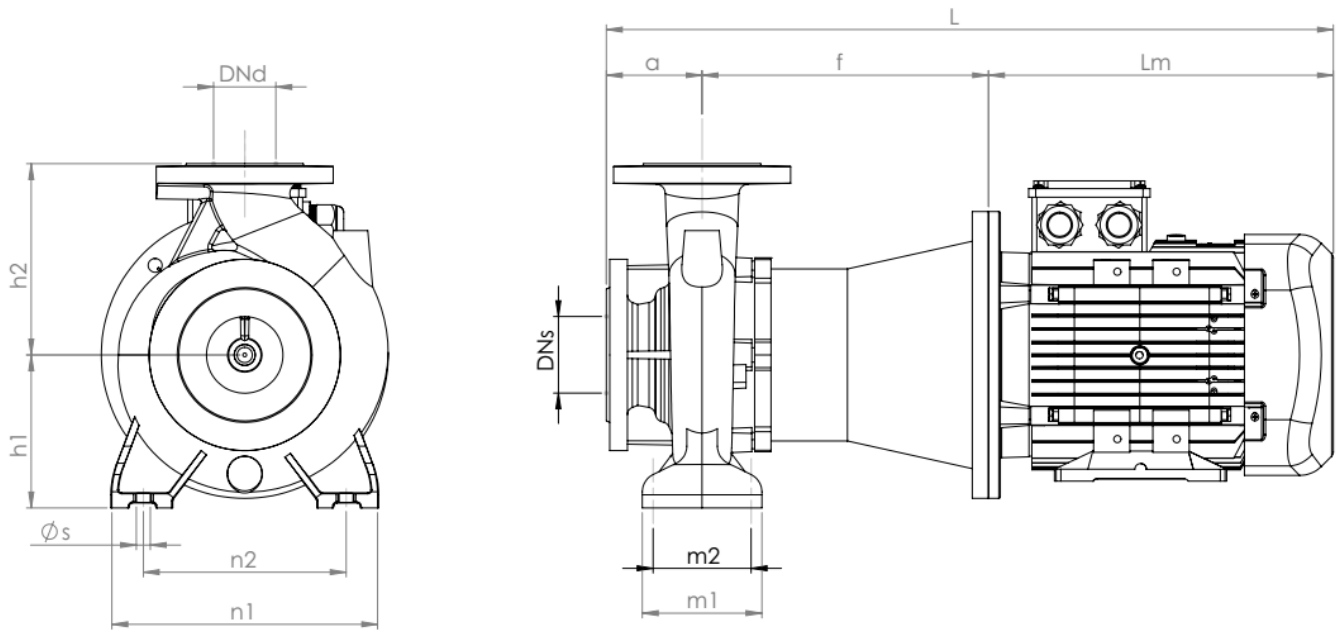

PUMP TYPE	MOTOR			FLANGES		GENERAL	PUMP									
	KW	IEC	Lm mm	DNd mm	DNs mm	L mm	a mm	f mm	h1 mm	h2 mm	n1 mm	n2 mm	m1 mm	m2 mm	s mm	
50-200	1450 rpm	1.1	90L	266.5	50	65	646	100	279.5	160	200	265	212	100	70	12
		1.5	90L	266.5			646		279.5							
		2.2	100L	292			676.5		284.5							
	2900 rpm	7.5	132M	395.5	50	65	790.5	100	295	160	200	265	212	100	70	12
		11	160M	666			1111		345							
		15	160L	666			1111		345							
		18.5	160L	666			1111		345							
65-160	1450 rpm	0.75	80	243.5	65	80	618.5	100	275	160	200	280	212	125	95	12
		1.1	90L	266.5			646.5		280							
		1.5	90L	266.5			646.5		280							
		2.2	100L	292			677		285							
	2900 rpm	5.5	132M	395.5	65	80	795	100	299.5	160	200	280	212	125	95	12
		7.5	132M	395.5			795		299.5							
		11	160M	666			1106		340							
		15	160L	666			1106		340							
		18.5	160L	666			1106		340							
		18.5	160L	666			1106		340							
65-200	1450 rpm	2.2	100L	292	65	80	679.5	100	287.5	180	225	320	250	125	95	12
		3	100L	292			679.5		287.5							
		4	112M	335.5			723		287.5							
		4	112M	335.5			723		287.5							
65-250	1450 rpm	5,5	132S	360	65	80	820	100	359,5	200	250	357	280	160	116	16
		5,5	132S	360			820		359,5							
80-160	1450 rpm	1.1	90L	266.5	80	100	671.5	125	280	180	225	320	250	125	95	12
		1.5	90L	266.5			671.5		280							
		2.2	100L	292			702		285							
		3	100L	292			702		285							
	2900 rpm	7.5	132M	395.5	80	100	820	125	299.5	180	225	320	250	125	95	12
		11	160M	666			1131		340							
		15	160L	666			1131		340							
		18.5	160L	666			1131		340							
80-250	1450 rpm	5,5	132S	360	80	100	845	125	359,5	200	280	397	315	160	116	16

NM mDrive Series

End Suction Norm Centrifugal Pumps with Magnetic Coupling

Performance Curves

NM mDrive 32-160



Mas Grup

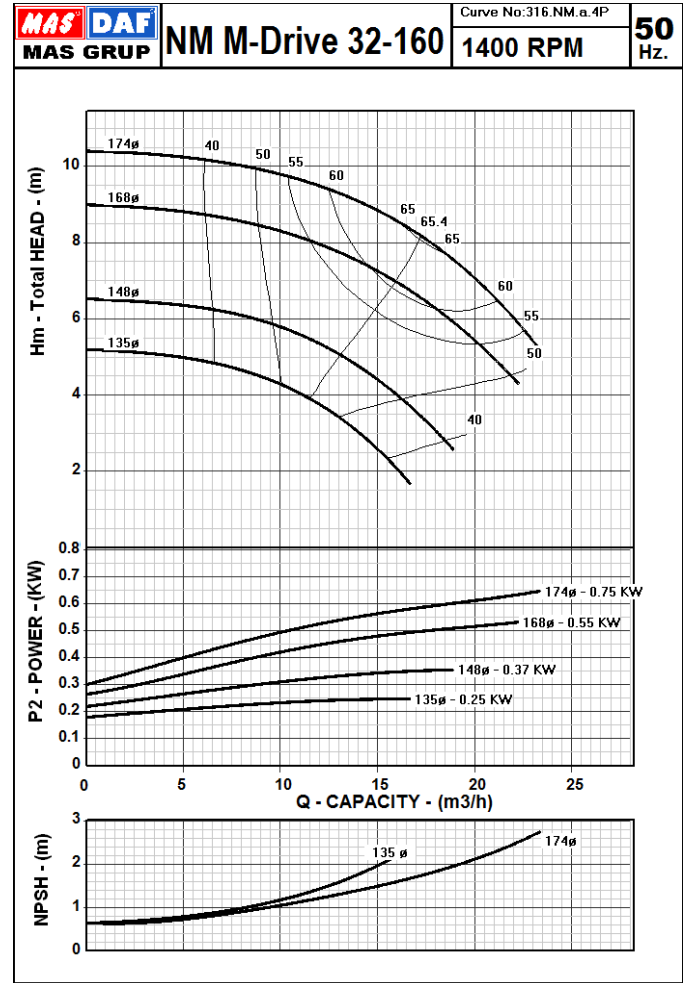
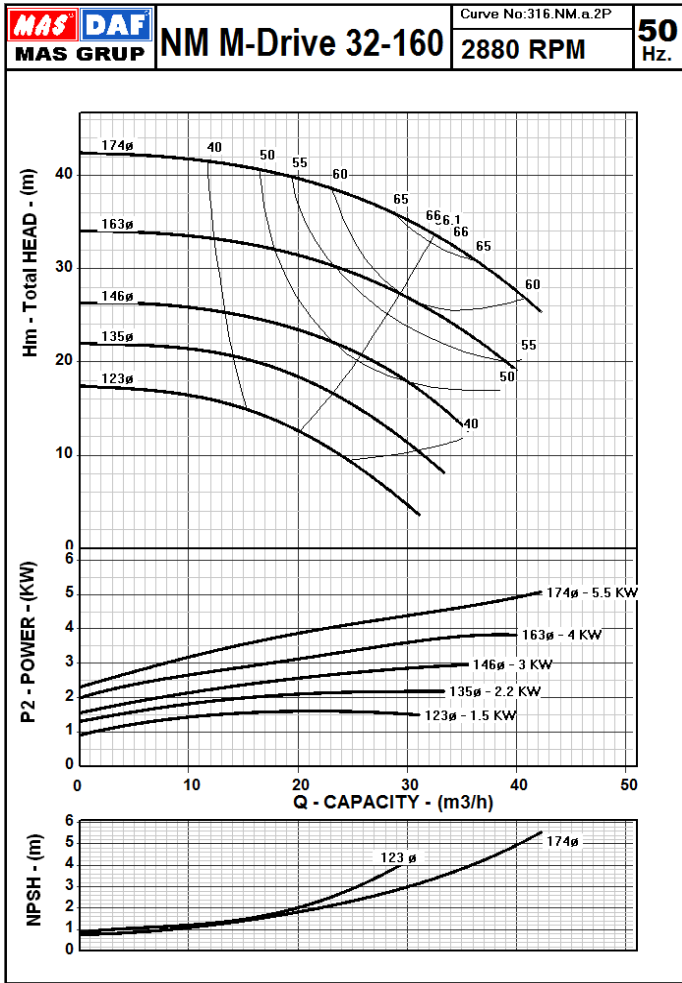

The Performance Curves 50 Hz are based on the kinematic viscosity 1 mm²/s and density 1g/cm³. Tolerances are acc. to ISO 9906 Annex A.

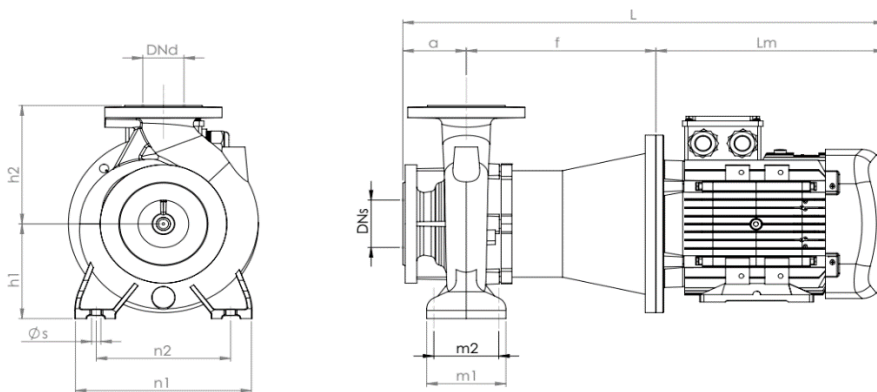

PUMP TYPE	MOTOR		FLANGES		GENERAL	PUMP										
	KW	IEC	Lm mm	DNd mm	DNs mm	L mm	a mm	f mm	h1 mm	h2 mm	n1 mm	n2 mm	m1 mm	m2 mm	s mm	
32-160	1450 rpm	0.55	80	243.5	32	50	597.5	80	274	132	160	240	190	100	70	12
		0.75	80	243.5			597.5		274							
	2900 rpm	1.5	90L	266.5	32	50	626	80	279.5	132	160	240	190	100	70	12
		2.2	90L	266.5			626		279.5							
		3	100L	292			656.5		284.5							
		4	112M	335.5			700		284.5							
	5.5	132S	360.5			750	309.5									

NM mDrive Series

End Suction Norm Centrifugal Pumps with Magnetic Coupling

Performance Curves

NM mDrive 32-200



Mas Grup

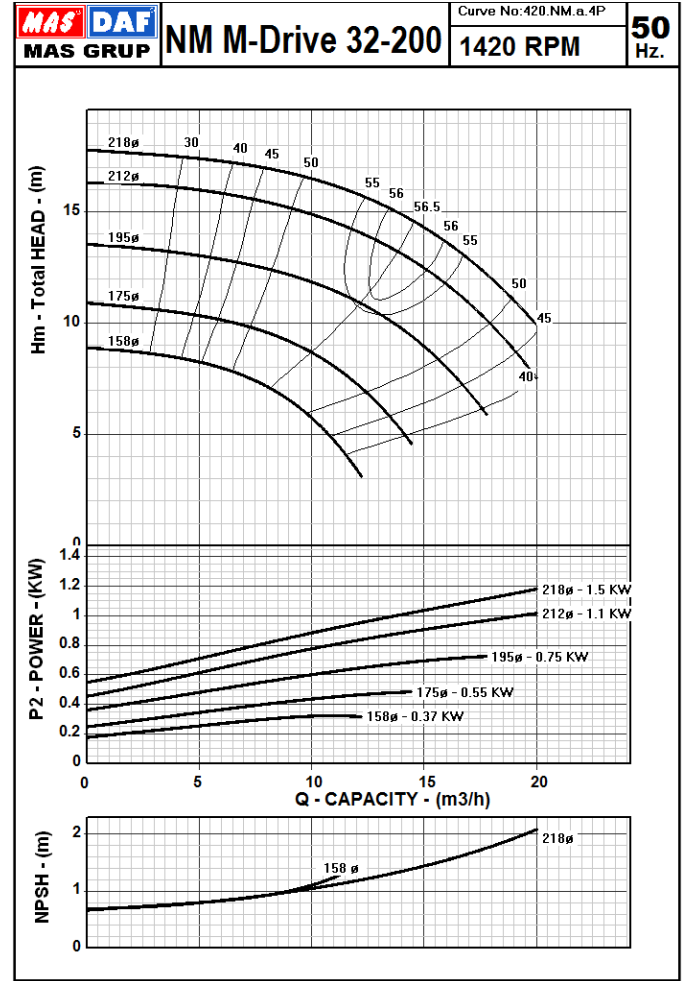
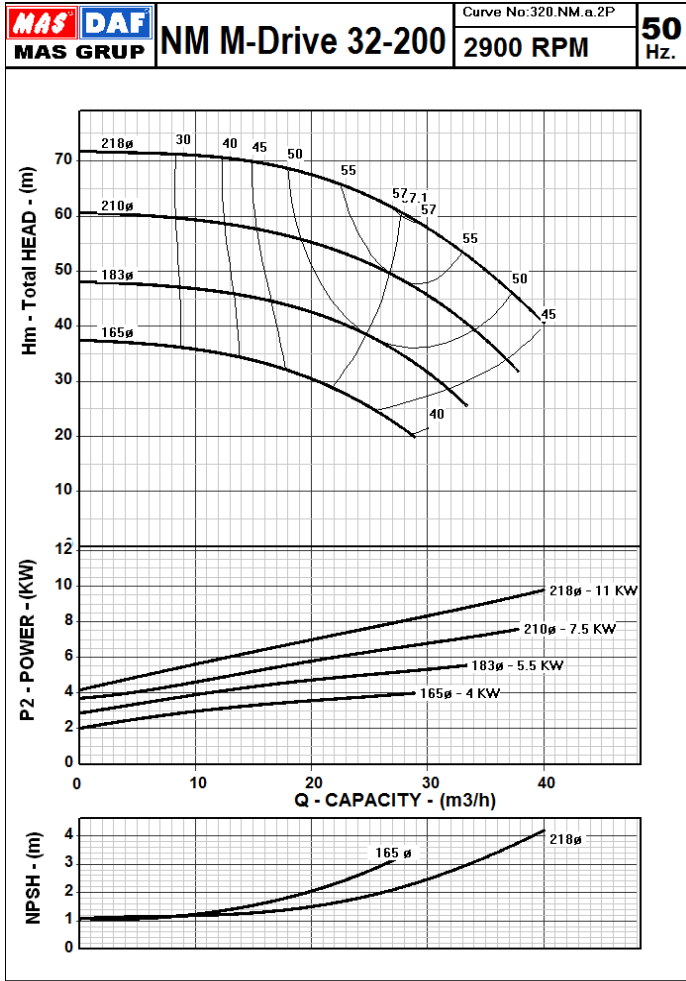

The Performance Curves 50 Hz are based on the kinematic viscosity 1 mm²/s and density 1g/cm³. Tolerances are acc. to ISO 9906 Annex A.

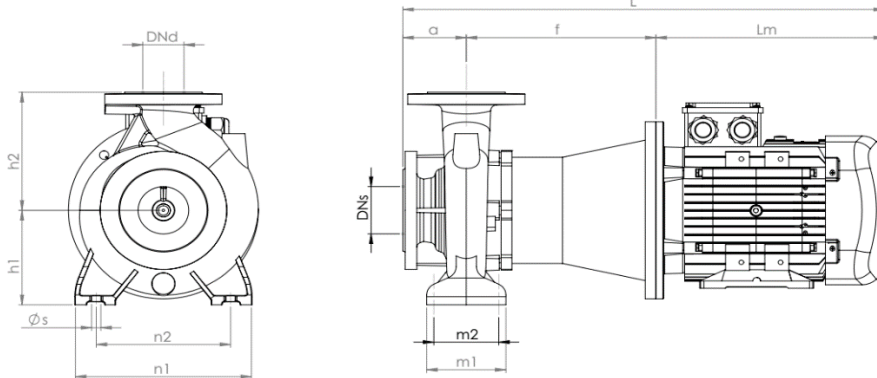

PUMP TYPE	MOTOR			FLANGES		GENERAL	PUMP									
	KW	IEC	Lm mm	DNd mm	DN _s mm	L mm	a mm	f mm	h1 mm	h2 mm	n1 mm	n2 mm	m1 mm	m2 mm	s mm	
32-200	1450 rpm	0.55	80	243.5	32	50	597.5	80	274	160	180	240	190	100	70	12
		0.75	80	243.5			597.5		274							
		1.1	90L	266.5			626		279.5							
		1.5	90L	266.5			626		279.5							
	2900 rpm	4	112M	335.5	32	50	700	80	284.5	160	180	240	190	100	70	12
		5.5	132S	360.5			735.5		295							
		7.5	132M	395.5			770.5		295							
		11	160M	666			475		345							

NM mDrive Series

End Suction Norm Centrifugal Pumps with Magnetic Coupling

Performance Curves

NM mDrive 40-160



Mas Grup

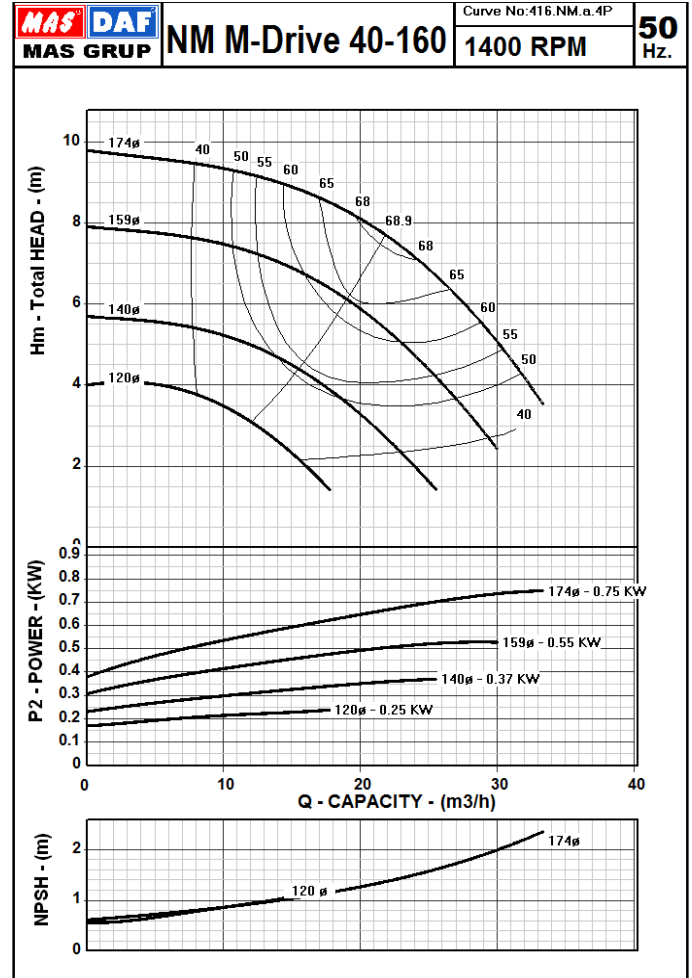
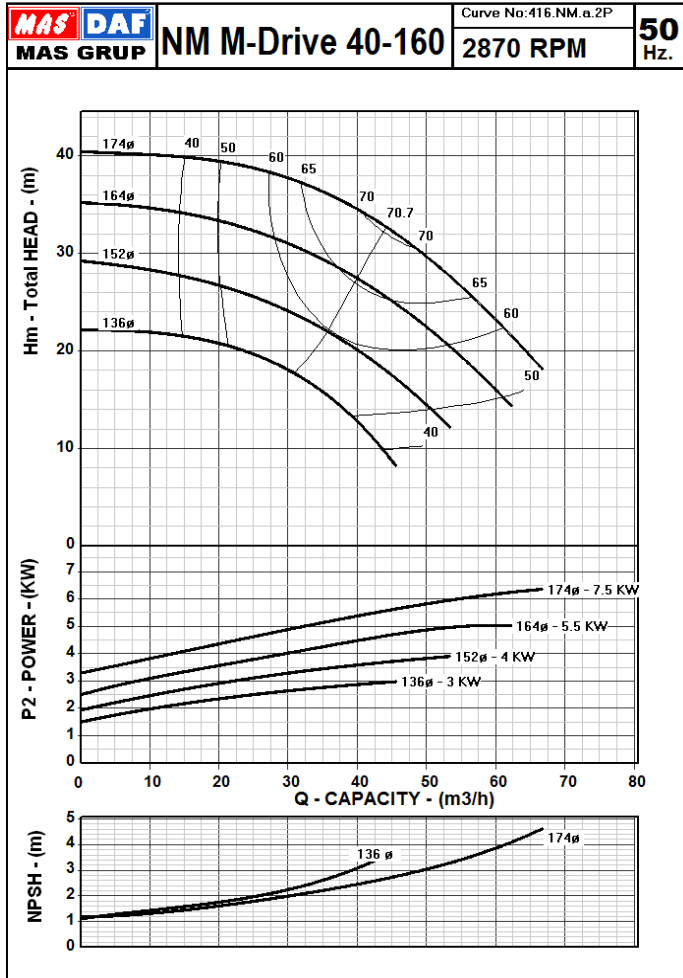

The Performance Curves 50 Hz are based on the kinematic viscosity 1 mm²/s and density 1g/cm³. Tolerances are acc. to ISO 9906 Annex A.

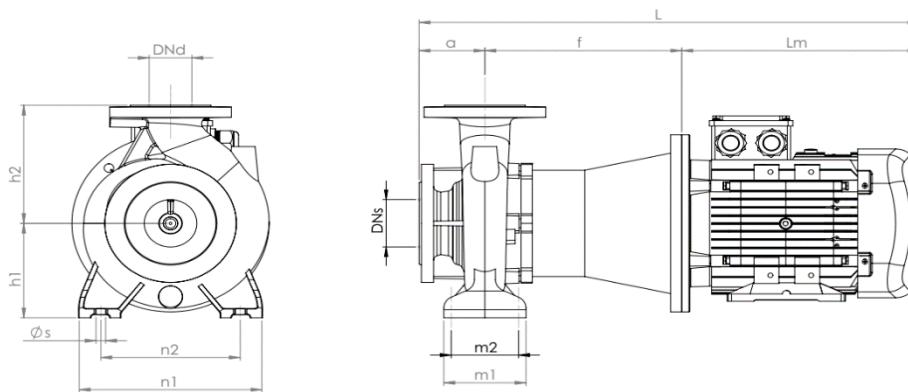

PUMP TYPE	MOTOR			FLANGES		GENERAL	PUMP									
	KW	IEC	Lm mm	DNd mm	DNs mm	L mm	a mm	f mm	h1 mm	h2 mm	n1 mm	n2 mm	m1 mm	m2 mm	s mm	
40-160	1450 rpm	0.55	80	243.5	40	65	597.5	80	274	132	160	240	190	100	70	12
		0.75	80	243.5					274							
	2900 rpm	3	100L	292	40	65	656.5	80	284.5	132	160	240	190	100	70	12
		4	112M	335.5			700		284.5							
		5.5	132S	360.5			750		309.5							
		7.5	132M	395.5			785		309.5							

NM mDrive Series

End Suction Norm Centrifugal Pumps with Magnetic Coupling

Performance Curves

NM mDrive 40-200



Mas Grup

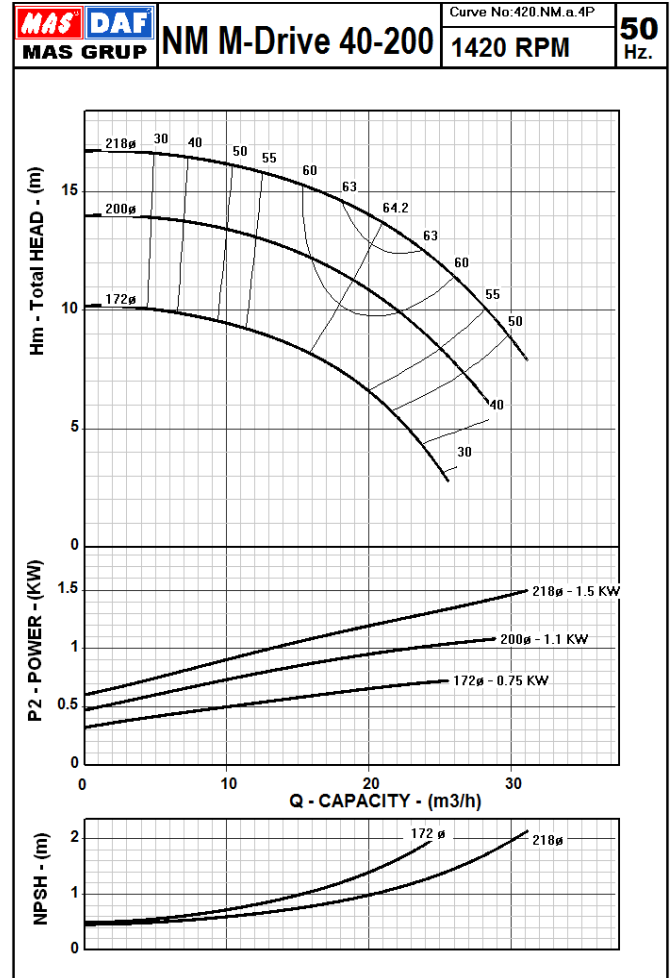
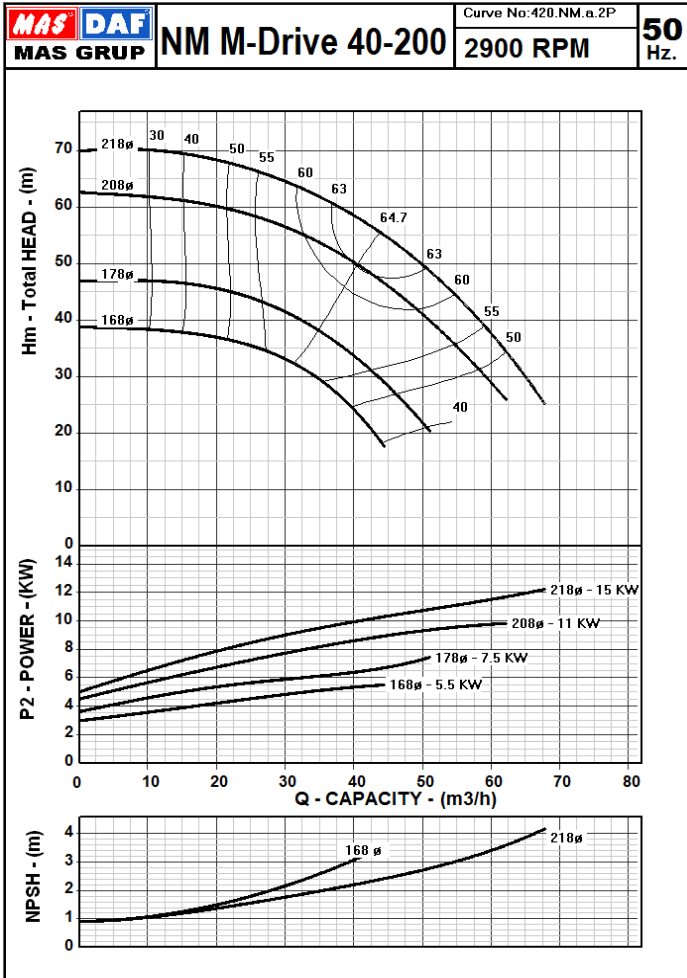

The Performance Curves 50 Hz are based on the kinematic viscosity 1 mm²/s and density 1g/cm³. Tolerances are acc. to ISO 9906 Annex A.

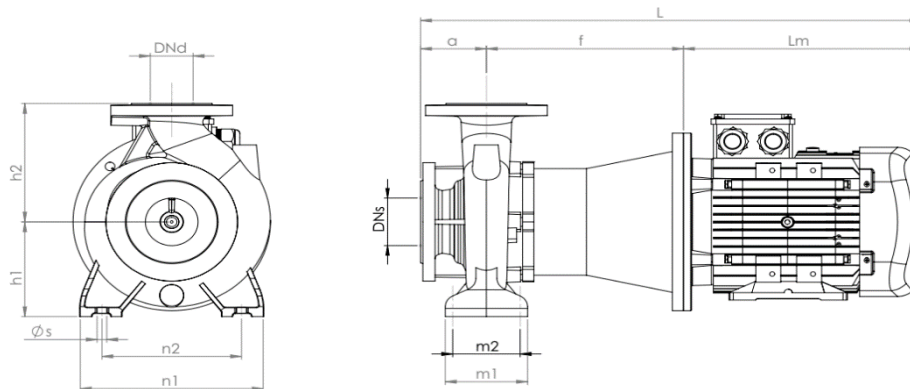

PUMP TYPE	MOTOR		Lm mm	FLANGES		GENERAL	PUMP										
	KW	IEC		DNd mm	DNs mm		L mm	a mm	f mm	h1 mm	h2 mm	n1 mm	n2 mm	m1 mm	m2 mm	s mm	
40-200	1450 rpm	0.55	80	243.5	40	65	617.5	100	274	160	180	265	212	100	70	12	
		0.75	80	243.5													274
		1.1	90L	266.5													279.5
		1.5	90L	266.5													279.5
	2900 rpm	5.5	132S	360.5	40	65	755.5	100	295	160	180	265	212	100	70	12	
		7.5	132M	395.5													295
		11	160M	666													345
		15	160L	666													345

NM mDrive Series

End Suction Norm Centrifugal Pumps with Magnetic Coupling

Performance Curves

NM mDrive 50-160



Mas Grup

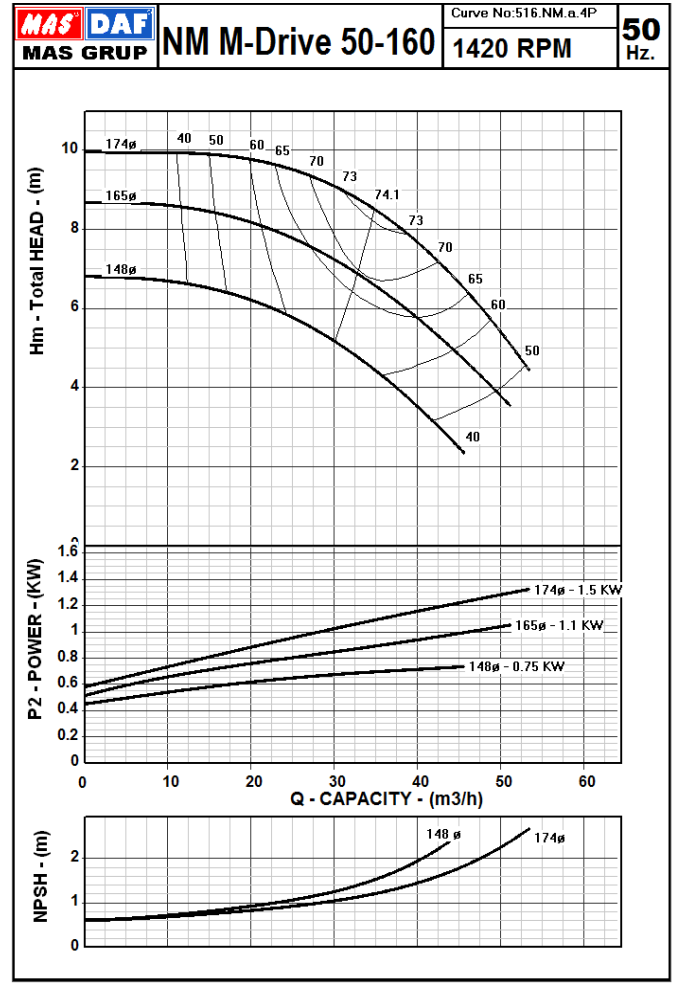
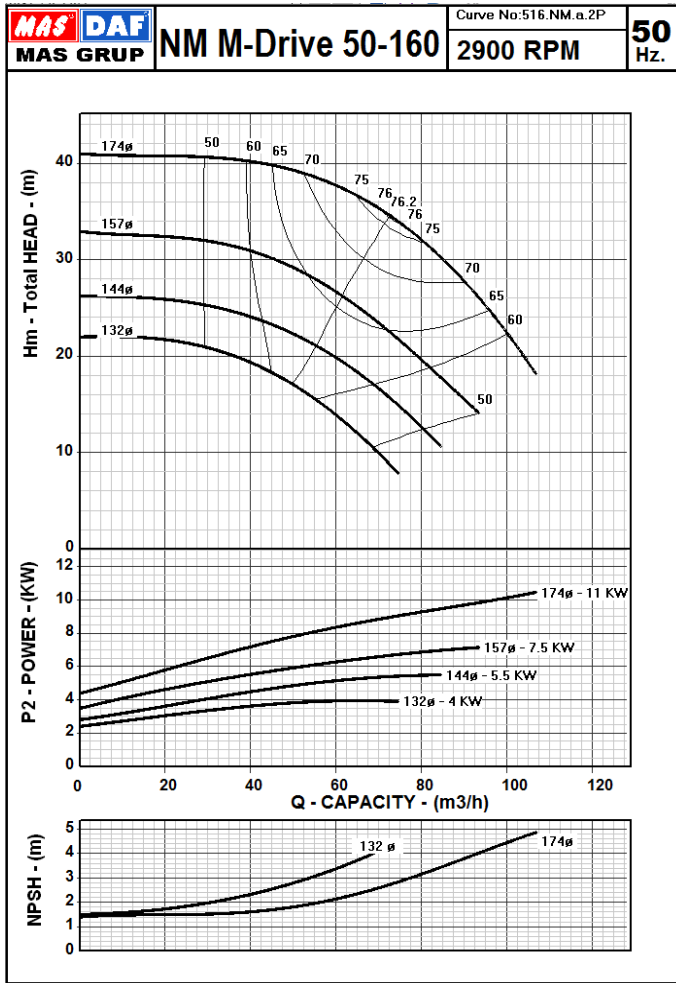

The Performance Curves 50 Hz are based on the kinematic viscosity 1 mm²/s and density 1g/cm³. Tolerances are acc. to ISO 9906 Annex A.

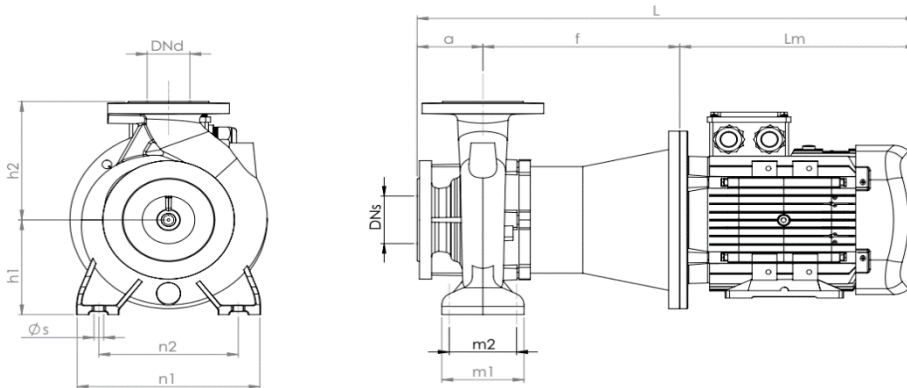

PUMP TYPE	MOTOR			FLANGES		GENERAL	PUMP										
	KW	IEC	Lm mm	DNd mm	DNs mm	L mm	a mm	f mm	h1 mm	h2 mm	n1 mm	n2 mm	m1 mm	m2 mm	s mm		
50-160	1450 rpm	0.75	80	243.5	50	65	617.5	100	274	160	180	265	212	100	70	12	
		1.1	90L	266.5													279.5
		1.5	90L	266.5													279.5
	2900 rpm	4	112M	335.5	50	65	720	100	284.5	160	180	265	212	100	70	12	
		5.5	132S	360.5													309.5
		7.5	132M	395.5													309.5
		11	160M	666													1111

NM mDrive Series

End Suction Norm Centrifugal Pumps with Magnetic Coupling

Performance Curves

NM mDrive 50-200



Mas Grup

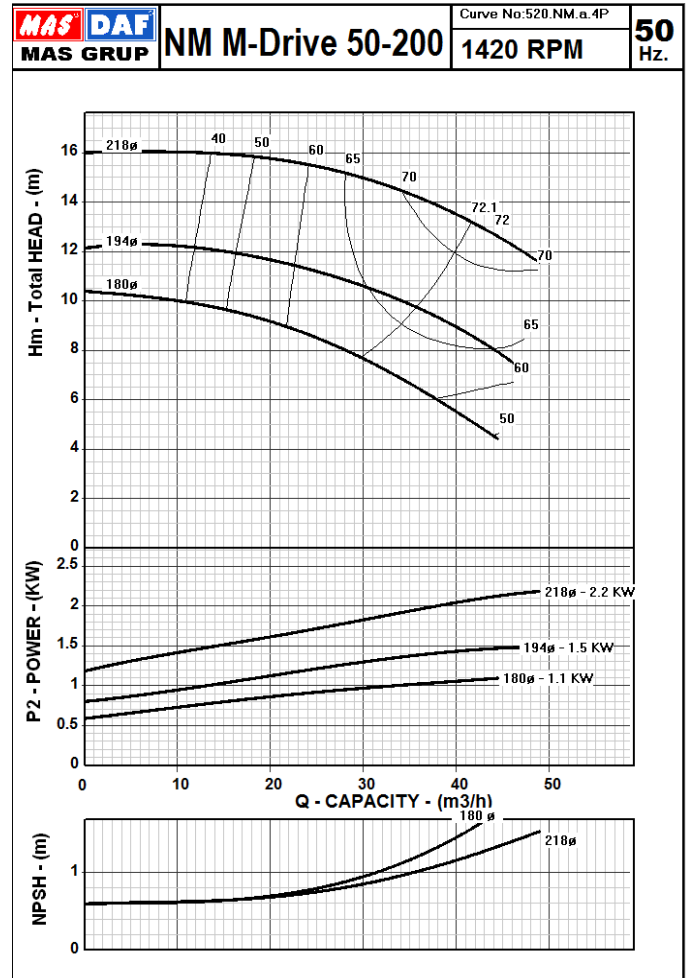
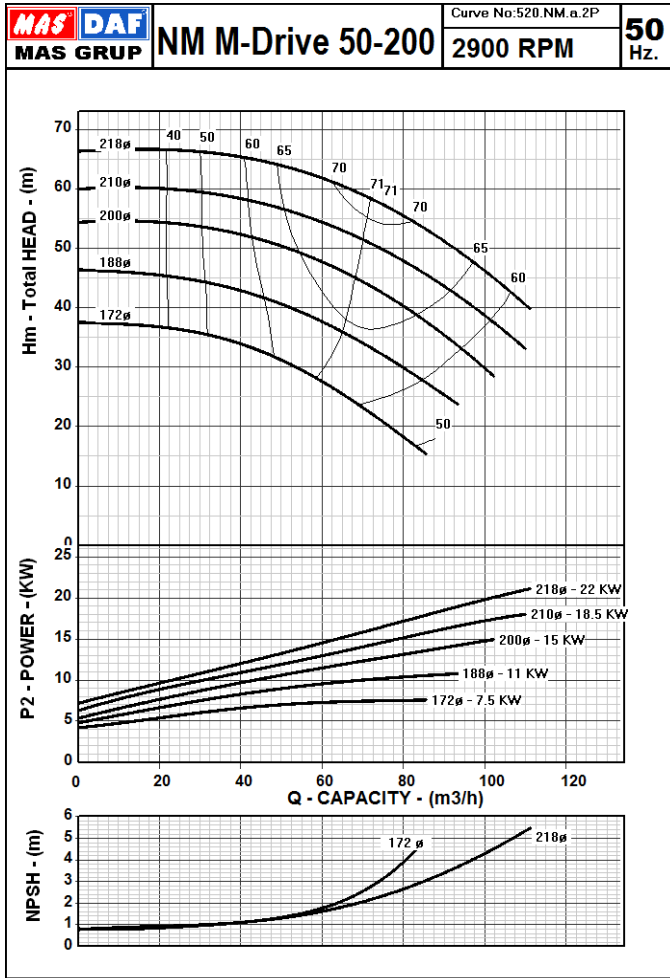

The Performance Curves 50 Hz are based on the kinematic viscosity 1 mm²/s and density 1g/cm³. Tolerances are acc. to ISO 9906 Annex A.

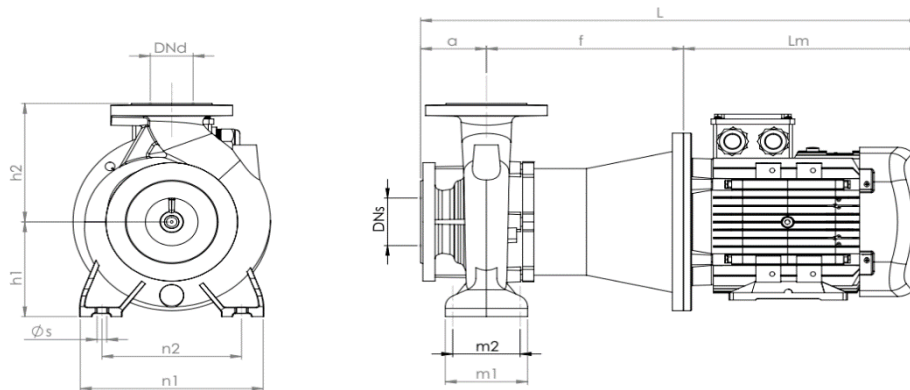

PUMP TYPE	MOTOR			FLANGES		GENERAL	PUMP									
	KW	IEC	Lm mm	DNd mm	DNs mm	L mm	a mm	f mm	h1 mm	h2 mm	n1 mm	n2 mm	m1 mm	m2 mm	s mm	
50-200	1450 rpm	1.1	90L	266.5	50	65	646	100	279.5	160	200	265	212	100	70	12
		1.5	90L	266.5					279.5							
		2.2	100L	292					284.5							
	2900 rpm	7.5	132M	395.5	50	65	790.5	100	295	160	200	265	212	100	70	12
		11	160M	666					345							
		15	160L	666					345							
		18.5	160L	666					345							

NM mDrive Series

End Suction Norm Centrifugal Pumps with Magnetic Coupling

Performance Curves

NM mDrive 65-160



Mas Grup

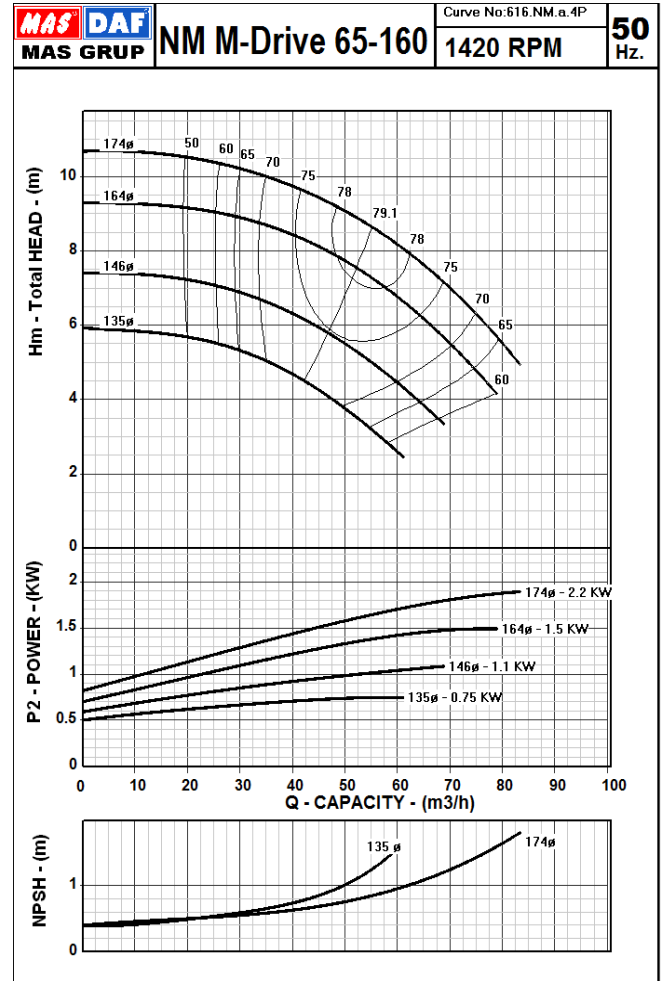
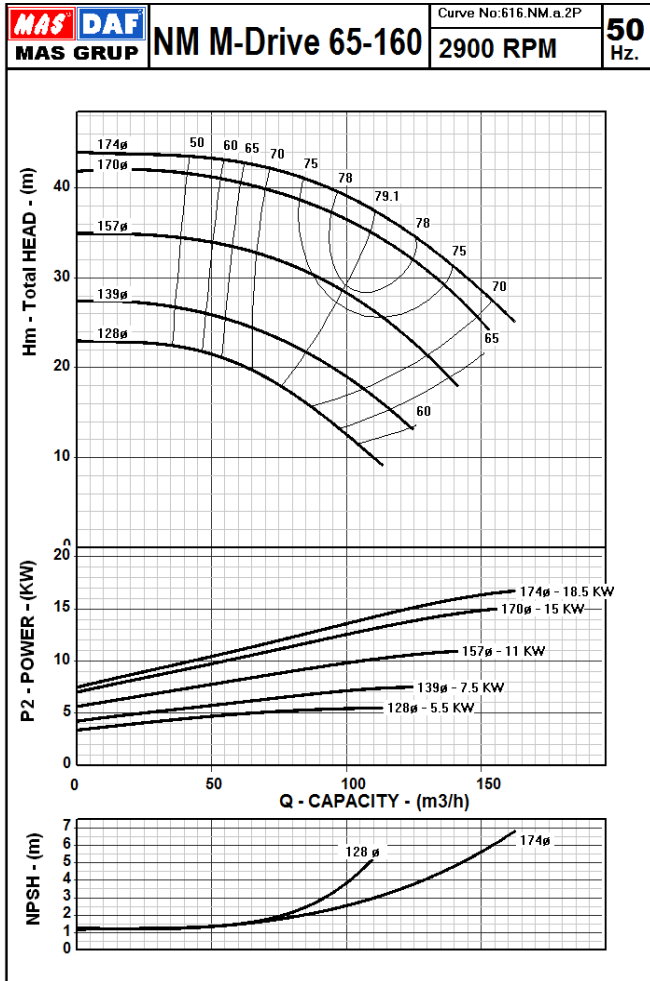

The Performance Curves 50 Hz are based on the kinematic viscosity 1 mm²/s and density 1g/cm³. Tolerances are acc. to ISO 9906 Annex A.

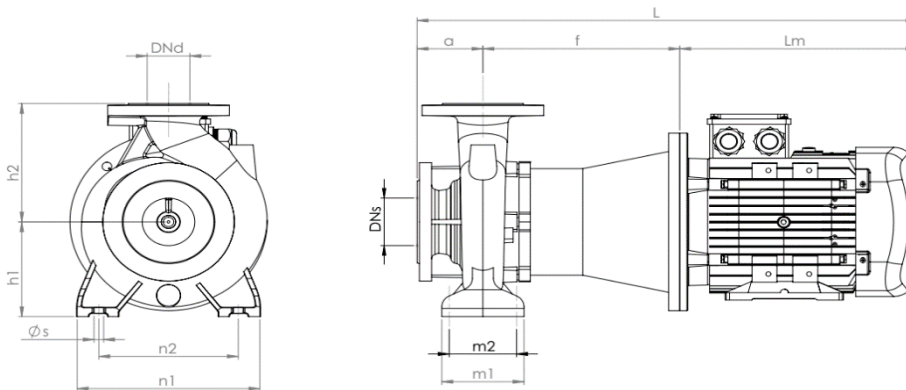

PUMP TYPE	MOTOR			FLANGES		GENERAL	PUMP									
	KW	IEC	Lm mm	DNd mm	DNs mm	L mm	a mm	f mm	h1 mm	h2 mm	n1 mm	n2 mm	m1 mm	m2 mm	s mm	
65-160	1450 rpm	0.75	80	243.5	65	80	618.5	100	275	160	200	280	212	125	95	12
		1.1	90L	266.5			646.5		280							
		1.5	90L	266.5			646.5		280							
		2.2	100L	292			677		285							
	2900 rpm	5.5	132M	395.5	65	80	795	100	299.5	160	200	280	212	125	95	12
		7.5	132M	395.5			795		299.5							
		11	160M	666			1106		340							
		15	160L	666			1106		340							
			18.5	160L	666			1106	340							

NM mDrive Series

End Suction Norm Centrifugal Pumps with Magnetic Coupling

Performance Curves

NM mDrive 65-200



Mas Grup

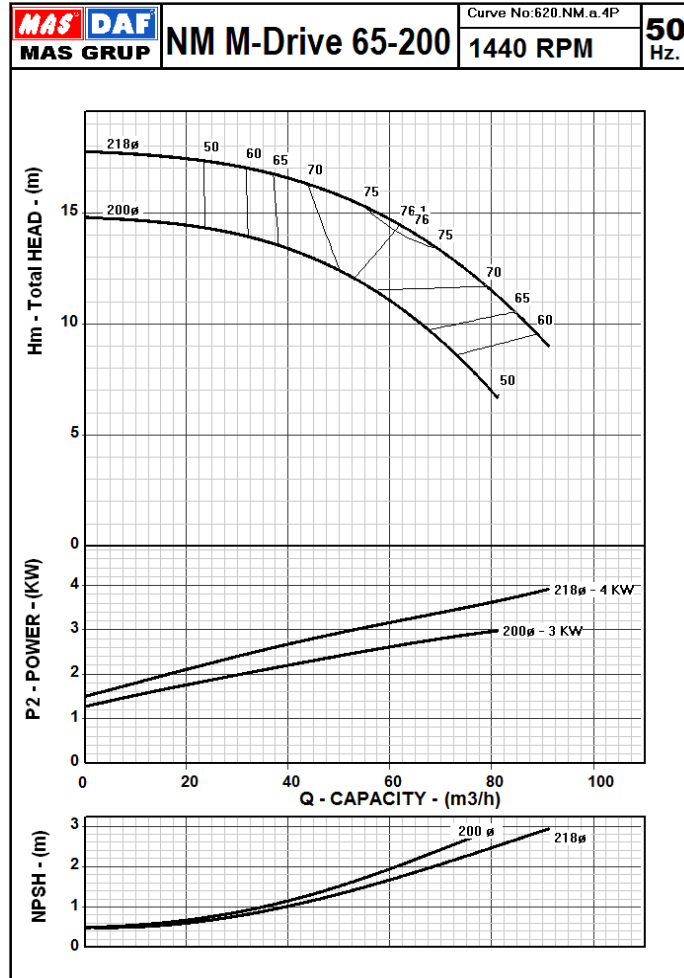

The Performance Curves 50 Hz are based on the kinematic viscosity 1 mm²/s and density 1g/cm³. Tolerances are acc. to ISO 9906 Annex A.

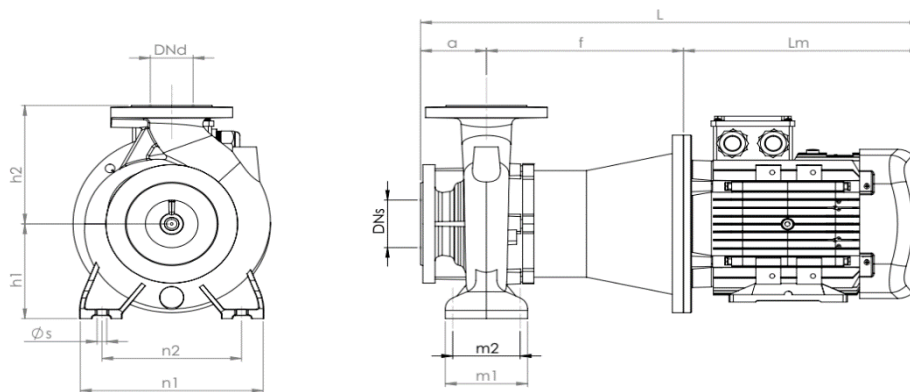

PUMP TYPE	MOTOR			FLANGES		GENERAL	PUMP									
	KW	IEC	Lm mm	DNd mm	DNs mm	L mm	a mm	f mm	h1 mm	h2 mm	n1 mm	n2 mm	m1 mm	m2 mm	s mm	
65-200	1450 rpm	2.2	100L	292	65	80	679.5	100	287.5	180	225	320	250	125	95	12
		3	100L	292			679.5		287.5							
		4	112M	335.5			723		287.5							

NM mDrive Series

End Suction Norm Centrifugal Pumps with Magnetic Coupling

Performance Curves

NM mDrive 65-250



Mas Grup

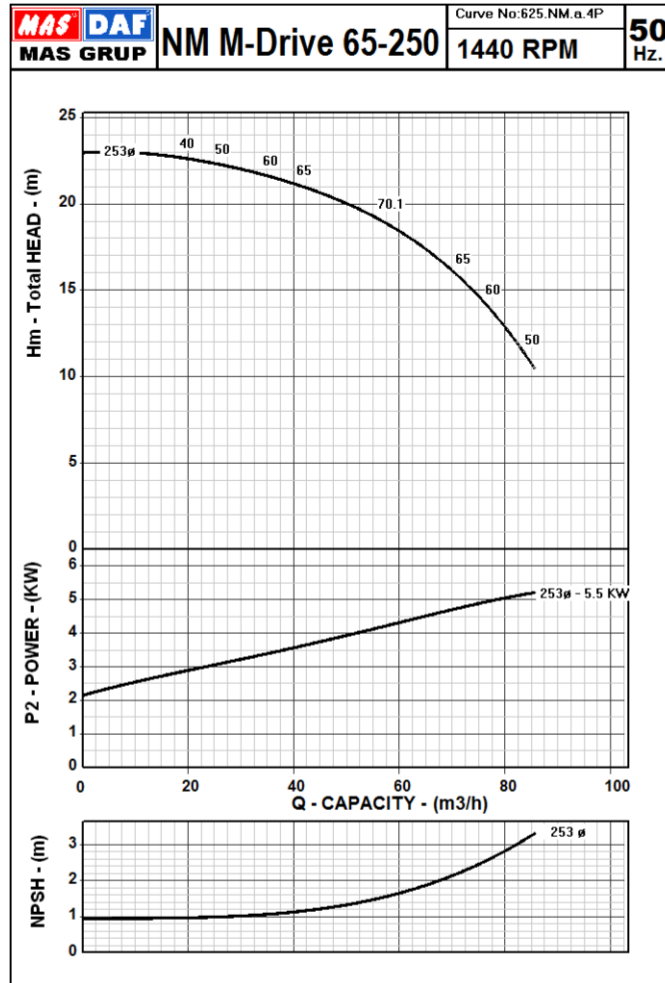

The Performance Curves 50 Hz are based on the kinematic viscosity 1 mm²/s and density 1g/cm³. Tolerances are acc. to ISO 9906 Annex A.

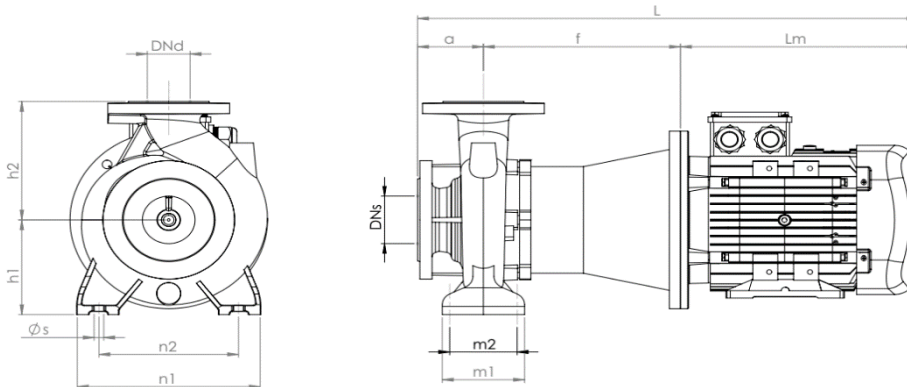

PUMP TYPE	MOTOR		FLANGES			GENERAL	PUMP									
	KW	IEC	Lm	DNd	DNs	L	a	f	h1	h2	n1	n2	m1	m2	s	
			mm	mm	mm	mm	mm	mm	mm	mm	mm	mm	mm	mm	mm	
65-250	1450 rpm	5,5	132S	360	65	80	820	100	359.5	200	250	357	280	160	116	16

NM mDrive Series

End Suction Norm Centrifugal Pumps with Magnetic Coupling

Performance Curves

NM mDrive 80-160



Mas Grup

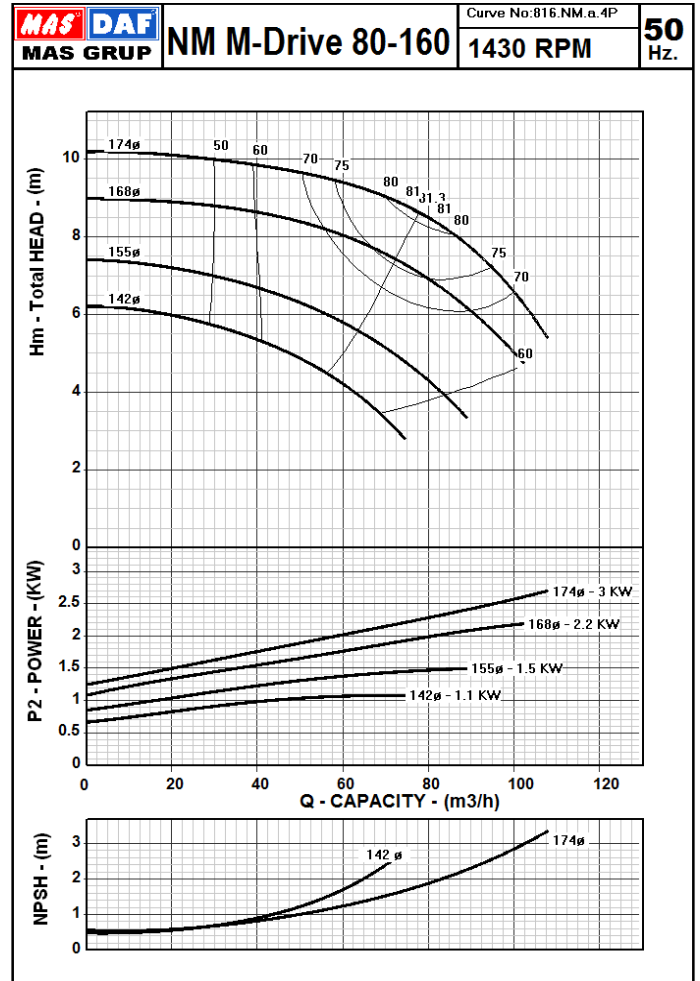
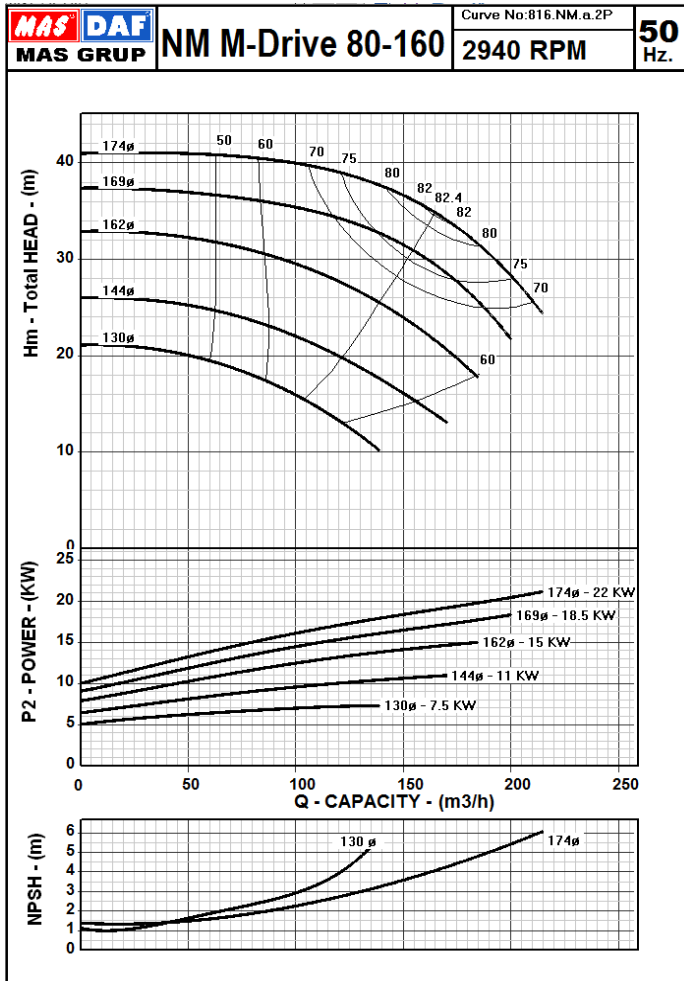

The Performance Curves 50 Hz are based on the kinematic viscosity 1 mm²/s and density 1g/cm³. Tolerances are acc. to ISO 9906 Annex A.

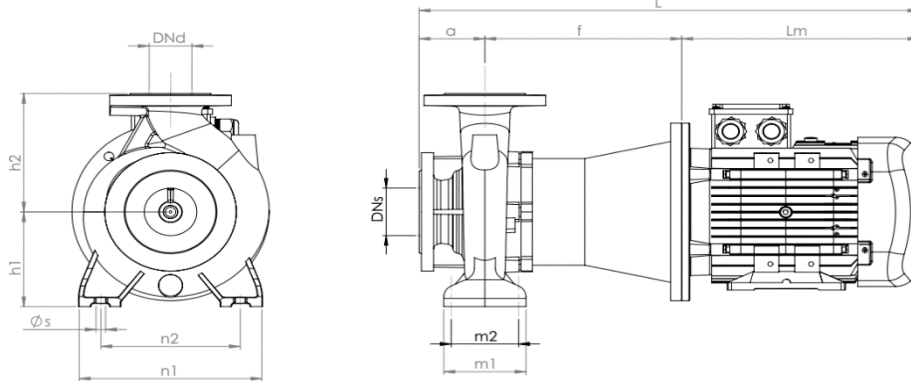

PUMP TYPE	MOTOR			FLANGES		GENERAL	PUMP									
	KW	IEC	Lm	DNd	DNs	L	a	f	h1	h2	n1	n2	m1	m2	s	
			mm	mm	mm	mm	mm	mm	mm	mm	mm	mm	mm	mm	mm	
80-160	1450 rpm	1.1	90L	266.5	80	100	671.5	125	280	180	225	320	250	125	95	12
		1.5	90L	266.5			671.5		280							
		2.2	100L	292			702		285							
		3	100L	292			702		285							
	2900 rpm	7.5	132M	395.5	80	100	820	125	299.5	180	225	320	250	125	95	12
		11	160M	666			1131		340							
		15	160L	666			1131		340							
		18.5	160L	666			1131		340							

NM mDrive Series

End Suction Norm Centrifugal Pumps with Magnetic Coupling

Performance Curves

NM mDrive 80-250



Mas Grup

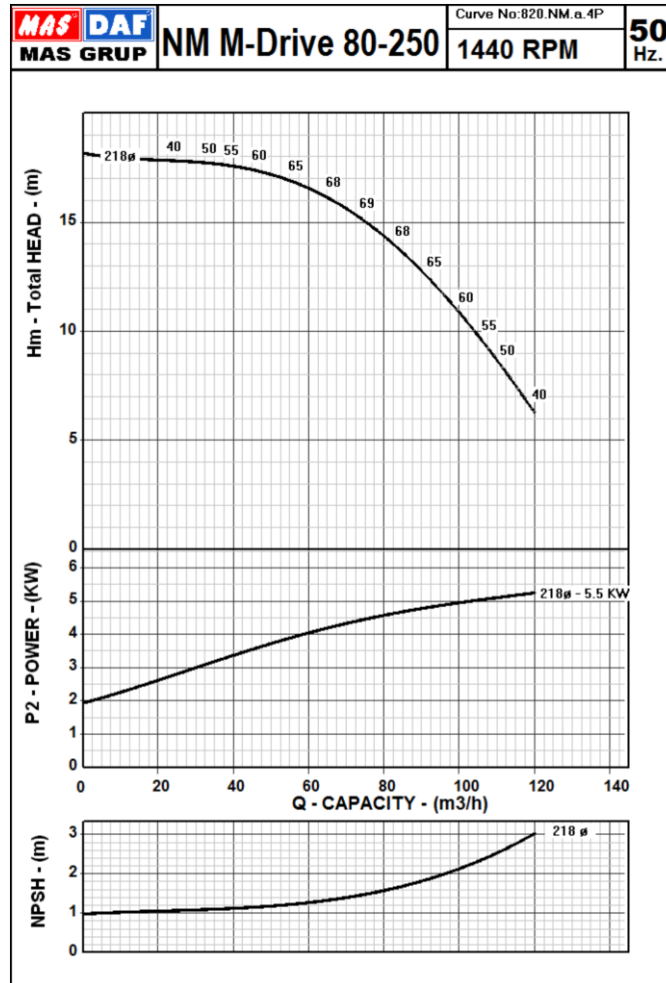

The Performance Curves 50 Hz are based on the kinematic viscosity 1 mm²/s and density 1g/cm³. Tolerances are acc. to ISO 9906 Annex A.

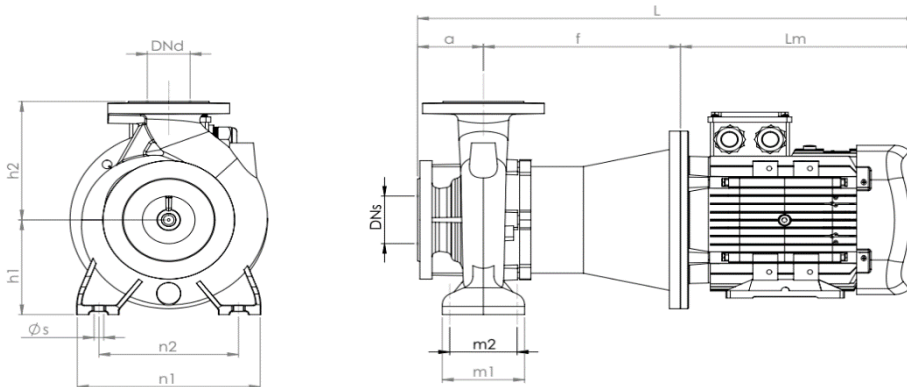

PUMP TYPE	MOTOR		FLANGES		GENERAL	PUMP										
	KW	IEC	Lm	DNd	DNs	L	a	f	h1	h2	n1	n2	m1	m2	s	
			mm	mm	mm	mm	mm	mm	mm	mm	mm	mm	mm	mm	mm	
80-250	1450 rpm	5,5	132S	360	80	100	845	125	359.5	200	280	397	315	160	116	16

NM mDrive Series

End Suction Norm Centrifugal Pumps with Magnetic Coupling

Permissible Loads and Torques on Pump Flanges



Mas Grup

Load and torque components on discharge flanges : $F_{xD}, F_{yD}, F_{zD}, M_{xD}, M_{yD}, M_{zD}$
 Load and torque components on suction flanges : $F_{xS}, F_{yS}, F_{zS}, M_{xS}, M_{yS}, M_{zS}$
 Dimension for force and torque : N, Nm

$F_{VD} = |F_{yD}|$: Amount of vertical load on discharge flange
 $F_{VS} = |F_{yS}|$: Amount of vertical load on suction flange
 $F_{HD} = (F_{xD}^2 + F_{zD}^2)^{1/2}$: Amount of horizontal load on discharge flange
 $F_{HS} = (F_{xS}^2 + F_{zS}^2)^{1/2}$: Amount of horizontal load on suction flange
 $M_D = (M_{xD}^2 + M_{yD}^2 + M_{zD}^2)^{1/2}$: Amount of torque on discharge flange
 $M_S = (M_{xS}^2 + M_{yS}^2 + M_{zS}^2)^{1/2}$: Amount of torque on suction flange

$\Sigma F_V = 2/3 \times F_{VD} + F_{VS}$: Sum of vertical loads
 $\Sigma F_H = F_{HD} + F_{HS}$: Sum of horizontal loads
 $\Sigma M = M_D + M_S$: Sum of torques

The load on the flange is permissible if the following condition is fulfilled.

$$(\Sigma F_V / \Sigma F_{Vmax})^2 + (\Sigma F_H / \Sigma F_{Hmax})^2 + (\Sigma M / \Sigma M_{max})^2 \leq 1$$

PUMP TYPE	F_{Vmax} [N]	F_{Hmax} [N]	M_{max} [Nm]
NM mDrive 32–160	2450	1850	350
NM mDrive 32–200			
NM mDrive 40–160	2550	1900	400
NM mDrive 40–200			
NM mDrive 50–160	2650	1950	450
NM mDrive 50–200			
NM mDrive 65–160	3000	2150	650
NM mDrive 65–200			
NM mDrive 65–250			
NM mDrive 80–160	3600	2450	950
NM mDrive 80–250			

Note: Pumps are mounted on base plate pressed of steel-sheet, filled with grout and discharge branch upward. Pump casing materials are GG 25, Bronze, GGG 40 and GS.

NM mDrive Series

End Suction Norm Centrifugal Pumps with Magnetic Coupling

Moment of Inertia without Coupling



Mas Grup

PUMP TYPE	MOMENT OF INERTIA I [kgm ²]					
	Impeller GG 25 ($\rho=7,3 \text{ kg/dm}^3$)		Impeller Bronze ($\rho=8,7 \text{ kg/dm}^3$)		Impeller Cast Steel ($\rho=7,8 \text{ kg/dm}^3$)	
	Without Water	With Water	Without Water	Without Water	With Water	Without Water
NM mDrive 32–160	0,0062	0,0072	0,0074	0,0084	0,0066	0,0076
NM mDrive 32–200	0,0123	0,0142	0,0147	0,0166	0,0131	0,0150
NM mDrive 40–160	0,0065	0,0072	0,0078	0,0085	0,0070	0,0077
NM mDrive 40–200	0,0124	0,0145	0,0148	0,0169	0,0132	0,0153
NM mDrive 50–160	0,0075	0,0087	0,0219	0,0231	0,0080	0,0092
NM mDrive 50–200	0,0136	0,0160	0,0142	0,0186	0,0125	0,0169
NM mDrive 65–160	0,0077	0,0100	0,0092	0,0115	0,0082	0,0105
NM mDrive 65–200	0,0150	0,0192	0,0179	0,0221	0,0160	0,0202
NM mDrive 65–250	0,0375	0,0465	0,0447	0,0537	0,0401	0,0491
NM mDrive 80–160	0,0098	0,0127	0,0117	0,0146	0,0105	0,0134
NM mDrive 80–250	0,0400	0,0525	0,0477	0,0602	0,0427	0,0552

For the water filling $\rho=1 \text{ kg/dm}^3$ is used. In case the handled liquid has a different density or the impeller is made of other materials having also a different density, calculate moment of inertia according to the following examples.

Example: Pump Size NM mDrive 80-160

Handled liquid density $\rho=1.25 \text{ kg/dm}^3$, impeller cast iron GG $\rho=7.3 \text{ kg/dm}^3$

$$I = (0.0127 - 0.0098) \times 1.25 + 0.0098 = 0.0669 \text{ kgm}^2$$

Handled liquid density $\rho=1 \text{ kg/dm}^3$, impeller $\rho=8 \text{ kg/dm}^3$ (conversion from GG $\rho=7.3 \text{ kg/dm}^3$)

$$I = 0.0098 \times 8 / 7.3 + (0.0127 - 0.0098) = 0.0668 \text{ kgm}^2$$

Handled liquid density $\rho=1.25 \text{ kg/dm}^3$, impeller $\rho=8 \text{ kg/dm}^3$
(Conversion from GG $\rho=7.3 \text{ kg/dm}^3$ and water $\rho=1 \text{ kg/dm}^3$)

$$I = 0.0098 \times 8 / 7.3 + (0.0127 - 0.0098) \times 1.25 = 0.0712 \text{ kgm}^2$$

NM mDrive Series

End Suction Norm Centrifugal Pumps with Magnetic Coupling

Exploded View



Mas Grup

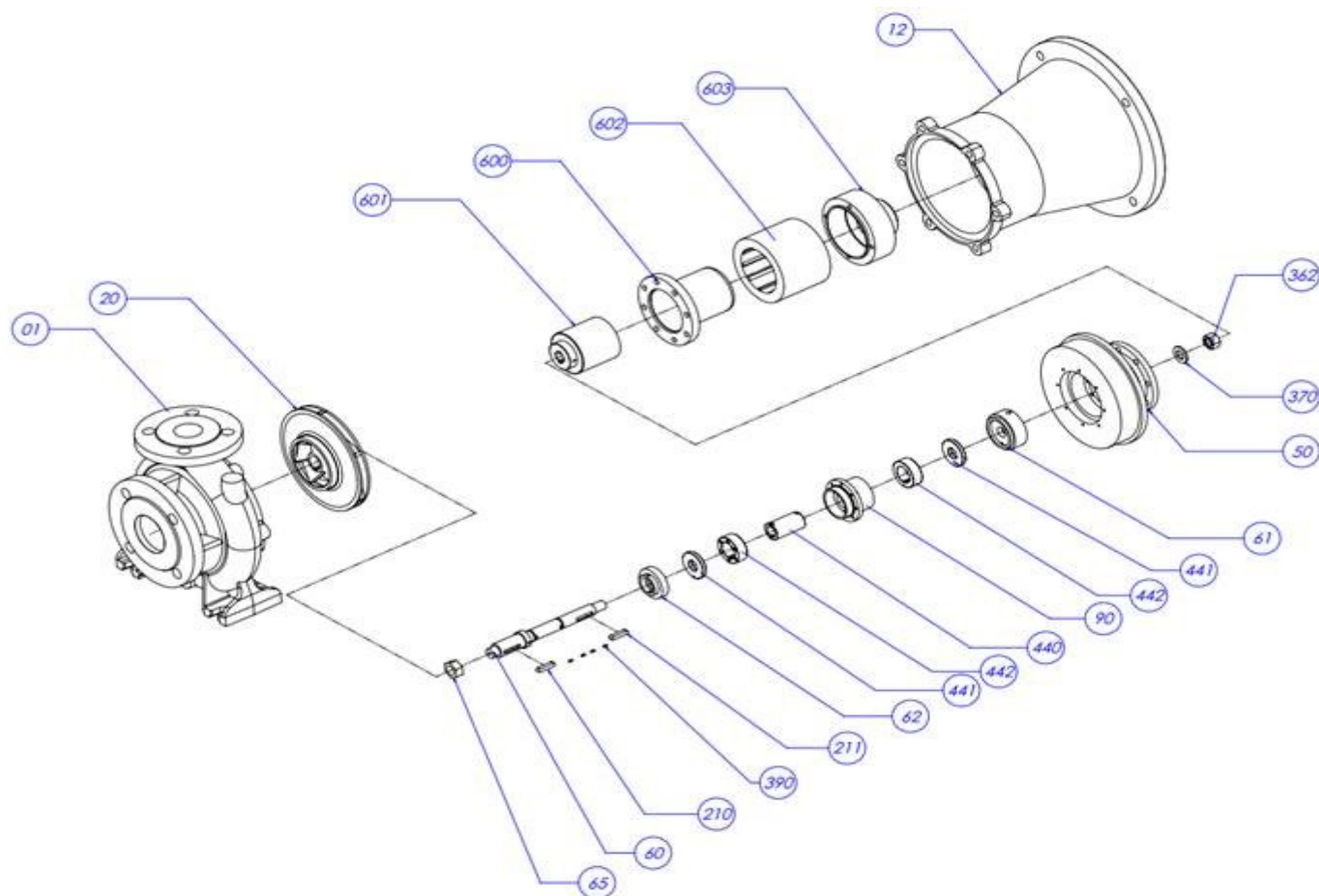

Part No	Part Name	Part No	Part Name
01	Volute Casing	362	Bearing Adjustment Nut
12	Adapter	370	Bearing Adjustment Nut Washer
20	Impeller	390	Pin
50	Main Bearing Housing	440	SiC Radial Bearing Sleeve
60	Shaft	441	SiC Axial Bearing
61	Axial Back Bearing Casing	442	SiC Radial Bearing Bushing
62	Axial Front Bearing Casing	600	Containment Shroud
65	Impeller Nut	601	Inner Magnetic Rotor
90	Radial Bearing Casing	602	Outer Magnetic Rotor
210	Impeller Key	603	Motor Connection Part
211	Coupling Key		



Mas Grup

Head Office / Center Service:

Aydınlı Mah. Birlik OSB. 1.No'lu Cadde No:17 Tuzla - İSTANBUL / TURKEY

Tel: +90 (216) 456 47 00 pbx Fax: +90 (216) 455 14 24

Ankara Regional Directorate:

Aşağı Öveçler Mah. 1329 Sok. No:6/9 Öveçler ANKARA / TURKEY

Tel: +90 (312) 472 81 60-67 Fax: +90 (312) 472 82 51

Factory:

1. Organize Sanayi Bölgesi Parsel 249/5 Beyköy - DÜZCE / TURKEY

Tel: +90 (380) 553 73 88 Fax: +90 (380) 553 71 29