

ULTRA HS/HX



Multistage Vertical

Stainless steel multistage vertical pumps. Suitable for clean non-loaded fluids, pressurizing system, irrigation, drinking and glycol water, water treatment, food industry, heating and air conditioning, washing system.

Construction features

Pump body	HS: cast iron GJL-250 HX: EN 1.4401 / AISI 316
Motor bracket	cast iron
Seal plate housing	HS: EN 1.4301 / AISI 304 HX: EN 1.4401 / AISI 316
Impellers, diffusers, shell	HS: EN 1.4301 / AISI 304 HX: EN 1.4401 / AISI 316
Pump shaft	HS: EN 1.4057 / AISI 431 HX: EN 1.4460 / AISI 329
Mechanical seal	silicon carbide-graphite-EPDM
Ambient temperature	max 40 °C
Liquid temperature	-15 ÷ +120 °C (Max 85° for domestic use)
Max operating pressure	32 bar (U 35-50) 25 bar (U 75-90)
Pump body gasket	EPDM

Motor

2 pole induction motor	3~ 230/400V-50Hz P ≤ 4kW, size B14 V1 3~ 400/690V-50Hz P > 4kW, size B5 V1 IE3 efficiency class
Insulation class	F
Protection degree	IP55



U 35 H S / X - 750/3-2R T

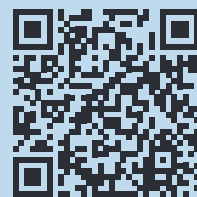
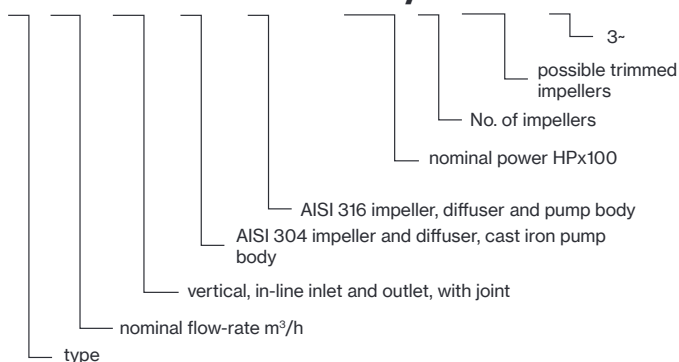

ULTRA 35-50

U 35/50... HS/HX	P2		Q (l/min - m ³ /h - US gpm)											
			0	417	500	566,7	666,7	700	800	900	1000	1066,7		
			0	25	30	34	40	42	48	54	60	64		
			0	109,9	131,9	149,5	175,9	184,7	211,0	237,4	263,8	281,4		
3-	HP	kW	H (m)											
U 35...-300/1 T	3	2,2	24,8	18,6	17,2	15,8	12,7	11,6						
U 35...-550/2-2R T	5,5	4	36,2	29,3	26,3	23,1	17,8	15,7						
U 35...-550/2-1R T	5,5	4	42,8	34,3	31,6	28,8	23,4	21,3						
U 35...-750/2 T	7,5	5,5	48,5	39,6	36,9	34,4	29,1	27,2						
U 35...-750/3-2R T	7,5	5,5	60,3	49,0	44,9	40,6	32,7	29,6						
U 35...-1000/3-1R T	10	7,5	67,5	54,1	50,1	46,1	38,0	35,0						
U 35...-1000/3 T	10	7,5	72,2	58,2	54,2	50,3	42,4	39,5						
U 35...-1000/4-2R T	10	7,5	85,1	68,6	63,9	58,4	48,8	44,7						
U 35...-1500/4-1R T	15	11	92,8	75,3	70,2	65,2	54,8	50,8						
U 35...-1500/4 T	15	11	99,4	81,0	76,3	71,8	62,2	58,5						
U 35...-1500/5-2R T	15	11	109,2	89,5	82,9	76,2	63,5	58,5						
U 35...-1500/5-1R T	15	11	115,1	93,6	87,0	80,6	67,5	62,4						
U 35...-2000/5 T	20	15	121,1	99,3	93,1	87,4	74,9	70,0						
U 35...-2000/6-2R T	20	15	133,8	109,6	101,7	93,9	78,7	72,7						
U 35...-2000/6-1R T	20	15	139,7	113,7	105,8	98,3	82,7	76,6						
U 35...-2000/6 T	20	15	145,6	119,3	111,9	105,0	90,1	84,2						
U 35...-2000/7-2R T	20	15	157,5	128,3	119,1	110,1	92,3	85,3						
U 35...-2000/7-1R T	20	15	163,3	132,3	123,2	114,4	96,2	89,1						
U 35...-2500/7 T	25	18,5	169,2	137,9	129,1	121,0	103,5	96,6						
U 35...-2500/8-2R T	25	18,5	185,5	152,0	142,0	132,5	112,8	105,1						
U 35...-2500/8-1R T	25	18,5	191,9	156,4	146,6	137,4	117,4	109,6						
U 35...-2500/8 T	25	18,5	198,4	162,5	153,0	144,6	125,4	117,8						
U 35...-3000/9-2R T	30	22	209,8	171,4	160,2	149,5	127,4	118,7						
U 35...-3000/9-1R T	30	22	216,2	175,8	164,7	154,4	131,9	123,1						
U 35...-3000/9 T	30	22	222,7	181,8	171,1	161,5	139,8	131,3						
U 35...-3000/10-2R T	30	22	234,0	190,6	178,1	166,3	141,7	132,1						
U 35...-3000/10-1R T	30	22	240,3	194,9	182,6	171,1	146,1	136,4						
U 35...-4000/10 T	40	30	246,8	200,9	188,9	178,2	154,0	144,5						
U 35...-4000/11-2R T	40	30	262,9	218,3	205,1	192,7	166,3	155,8						
U 35...-4000/11-1R T	40	30	269,5	222,9	209,9	197,8	171,2	160,5						
U 35...-4000/11 T	40	30	276,2	229,2	216,5	205,3	179,4	169,1						
U 35...-4000/12-2R T	40	30	288,1	240,0	226,0	213,0	184,4	173,3						
U 35...-4000/12-1R T	40	30	294,7	244,8	230,9	218,4	189,7	178,6						
U 35...-4000/12 T	40	30	301,4	251,1	237,8	226,0	197,6	188,0						
U 35...-4000/13-2R T	40	30	313,0	260,4	245,3	231,3	200,3	188,3						
U 35...-4000/13-1R T	40	30	319,6	265,2	250,2	236,6	205,6	193,6						
U 35...-4000/13 T	40	30	326,3	271,5	257,0	244,2	213,5	202,9						
U 50...-400/1-1R T	4	3	19,6			16,0	14,6	14,0	12,1	9,7	7,0	4,9		
U 50...-550/1 T	5,5	4	25,1			20,4	19,0	18,5	16,8	14,8	12,5	10,4		
U 50...-750/2-2R T	7,5	5,5	38,4			33,9	31,5	30,5	27,4	23,7	19,3	16,0		
U 50...-1000/2 T	10	7,5	49,0			42,0	39,8	38,8	35,5	31,8	27,5	24,1		
U 50...-1500/3-2R T	15	11	63,0			55,9	52,7	51,4	46,8	41,5	35,1	30,3		
U 50...-1500/3 T	15	11	74,2			65,0	62,1	60,9	56,5	51,3	45,5	41,0		
U 50...-2000/4-2R T	20	15	87,5			77,4	73,3	71,6	65,5	58,4	50,1	43,8		
U 50...-2000/4 T	20	15	97,5			86,4	82,8	81,3	75,4	68,5	60,8	54,7		
U 50...-2500/5-2R T	25	18,5	112,1			99,9	95,0	92,9	85,5	76,7	66,6	58,8		
U 50...-2500/5 T	25	18,5	122,3			109,1	104,7	102,9	95,6	87,1	77,5	70,0		
U 50...-3000/6-2R T	30	22	136,0			120,7	114,9	112,4	103,4	92,9	80,8	71,5		
U 50...-3000/6 T	30	22	146,0			129,8	124,5	122,2	113,3	103,0	91,6	82,5		
U 50...-4000/7-2R T	40	30	162,6			146,4	140,1	137,3	127,2	115,2	101,3	90,8		
U 50...-4000/7 T	40	30	173,0			155,9	150,1	147,7	137,7	126,0	112,7	102,5		
U 50...-4000/8-2R T	40	30	187,2			168,3	161,1	158,0	146,4	132,7	116,8	104,8		
U 50...-4000/8 T	40	30	197,5			177,7	171,1	168,2	156,8	143,4	128,2	116,5		
U 50...-5000/9-2R T	50	37	211,7			190,2	182,2	178,7	165,7	150,3	132,6	119,1		
U 50...-5000/9 T	50	37	222,0			199,7	192,2	188,9	176,1	161,0	143,9	130,7		
U 50...-5000/10-2R T	50	37	236,1			211,9	203,0	199,1	184,6	167,5	147,9	132,9		
U 50...-5000/10 T	50	37	246,4			221,3	212,9	209,3	195,0	178,1	159,1	144,4		
U 50...-6000/11-2R T	60	45	261,5			235,3	225,7	221,5	205,7	187,0	165,5	149,1		
U 50...-6000/11 T	60	45	271,8			244,8	235,7	231,8	216,2	197,7	176,9	160,9		
U 50...-6000/12-2R T	60	45	286,0			257,2	246,7	242,1	224,8	204,5	181,0	163,2		
U 50...-6000/12 T	60	45	296,3			266,6	256,7	252,4	235,3	215,2	192,4	174,9		
U 50...-6000/13-2R T	60	45	310,4			278,9	267,6	262,7	243,9	221,8	196,5	177,2		



U 75/90... HS/HX	P2		Q (l/min - m³/h - US gpm)								
			0	500	666,7	750	833,3	1000	1166,7	1333,3	1466,7
			0	30	40	45	50	60	70	80	88
			0	131,9	175,9	197,9	219,8	263,8	307,8	351,7	386,9
3-	H (m)										
	HP	kW									
U 75...-550/1-1R T	5,5	4	21,3	18,2	17,0	16,3	15,5	13,3	10,3	6,8	3,7
U 75...-750/1 T	7,5	5,5	30,2	24,8	23,0	22,3	21,7	20,3	18,3	15,4	12,2
U 75...-1000/2-2R T	10	7,5	38,9	37,2	35,8	34,8	33,8	30,5	25,8	20,3	14,6
U 75...-1500/2-1R T	15	11	47,8	44,3	42,6	41,6	40,6	38,0	34,2	29,3	24,0
U 75...-1500/2 T	15	11	59,3	51,2	48,0	46,8	45,5	43,2	39,9	35,3	30,8
U 75...-2000/3-2R T	20	15	67,3	63,0	60,6	59,1	57,6	53,4	47,2	39,5	31,4
U 75...-2000/3-1R T	20	15	75,5	69,2	66,3	64,8	63,2	59,5	54,1	46,9	38,7
U 75...-2500/3 T	25	18,5	89,6	77,6	72,8	70,9	69,0	65,7	60,7	53,9	47,2
U 75...-2500/4-2R T	25	18,5	95,5	88,6	85,1	83,2	81,1	76,0	68,3	58,5	47,9
U 75...-3000/4-1R T	30	22	103,7	94,7	90,9	88,8	86,7	82,1	75,2	65,9	55,3
U 75...-3000/4 T	30	22	111,8	100,8	96,7	94,5	92,4	88,4	82,3	73,3	62,9
U 75...-4000/5-2R T	40	30	125,3	116,2	111,8	109,5	107,0	101,1	92,1	80,4	68,0
U 75...-4000/5-1R T	40	30	133,9	122,7	117,9	115,5	113,0	107,6	99,5	88,4	76,2
U 75...-4000/5 T	40	30	142,4	129,2	124,0	121,5	119,0	114,1	106,9	96,3	84,6
U 75...-4000/6-2R T	40	30	153,5	141,6	136,2	133,3	130,3	123,4	112,9	99,0	84,1
U 75...-5000/6-1R T	50	37	162,1	148,2	142,4	139,4	136,4	130,0	120,4	107,1	92,5
U 75...-5000/6 T	50	37	170,6	154,7	148,5	145,4	142,3	136,5	127,8	115,0	100,9
U 75...-5000/7-2R T	50	37	181,7	167,0	160,6	157,2	153,6	145,7	133,7	117,7	100,3
U 75...-5000/7-1R T	50	37	190,1	173,5	166,6	163,1	159,5	152,1	141,0	125,5	108,3
U 75...-6000/7 T	60	45	199,5	181,1	173,8	170,3	166,7	160,0	149,9	135,1	118,9
U 75...-6000/8-2R T	60	45	210,6	193,5	186,0	182,2	178,1	169,3	156,0	137,9	118,4
U 75...-6000/8-1R T	60	45	219,2	200,0	192,1	188,2	184,1	175,8	163,4	145,9	126,6
U 75...-6000/8 T	60	45	227,7	206,5	198,2	194,1	190,1	182,3	170,7	153,8	135,1

U 75/90... HS/HX	P2		Q (l/min - m³/h - US gpm)									
			0	750	833,3	1000	1166,7	1333,3	1466,7	1666,7	1833,3	1916,7
			0	45	50	60	70	80	88	100	110	115
			0	197,9	219,8	263,8	307,8	351,7	386,9	439,7	483,6	505,6
3-	H (m)											
	HP	kW										
U 90...-750/1-1R T	7,5	5,5	26,4	20,5	19,9	18,7	17,3	15,5	13,2	9,5	5,7	3,5
U 90...-1000/1 T	10	7,5	35,6	27,0	25,6	23,2	21,9	20,4	18,8	15,7	12,4	10,5
U 90...-1500/2-2R T	15	11	49,6	42,4	41,3	39,0	36,6	33,2	29,4	22,7	15,7	11,7
U 90...-2000/2 T	20	15	69,2	56,6	54,5	50,5	47,3	44,3	41,6	36,3	30,5	27,3
U 90...-2500/3-2R T	25	18,5	80,4	70,8	69,1	65,6	62,2	57,7	53,0	44,3	34,9	30,4
U 90...-3000/3 T	30	22	92,4	82,6	80,6	76,7	73,2	69,4	65,5	57,8	49,7	45,2
U 90...-4000/4-2R T	40	30	113,1	100,6	98,2	93,5	89,0	83,5	77,5	66,5	54,6	48,5
U 90...-4000/4 T	40	30	125,6	113,0	110,4	105,2	100,6	95,7	90,7	80,8	70,2	64,4
U 90...-5000/5-2R T	50	37	144,1	128,4	125,4	119,3	113,7	106,9	99,7	86,1	71,6	64,1
U 90...-5000/5 T	50	37	156,6	140,7	137,4	130,9	125,2	119,1	112,8	100,3	87,1	79,8
U 90...-6000/6-2R T	60	45	175,9	157,0	153,4	146,1	139,3	131,4	122,9	107,0	89,8	80,8
U 90...-6000/6 T	60	45	188,4	169,5	165,6	157,8	150,9	143,6	136,2	121,3	105,5	96,7



35 HS/HX

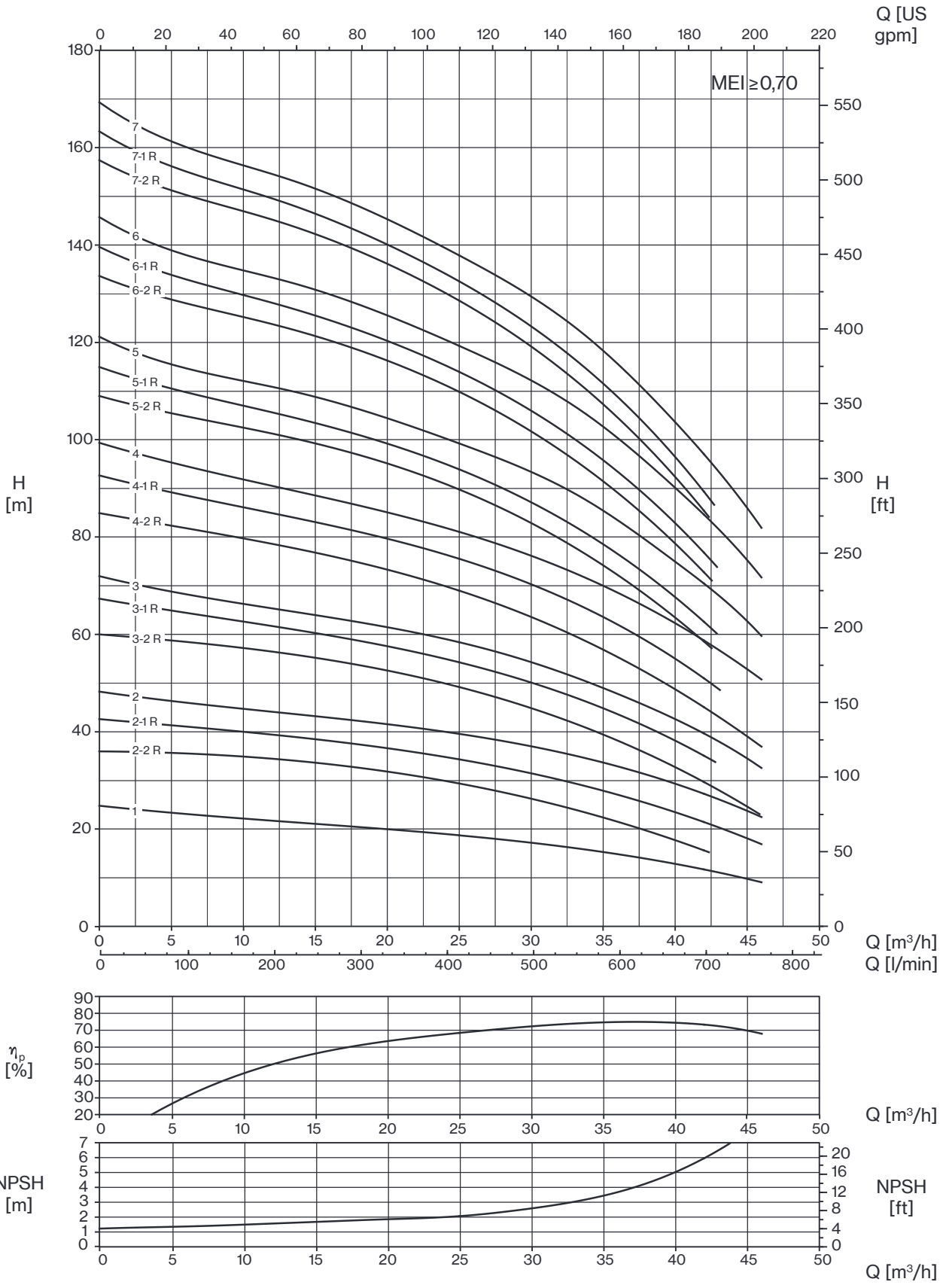

The hydraulic characteristics are guaranteed, according to ISO Standard 9906:2012, grade 3B



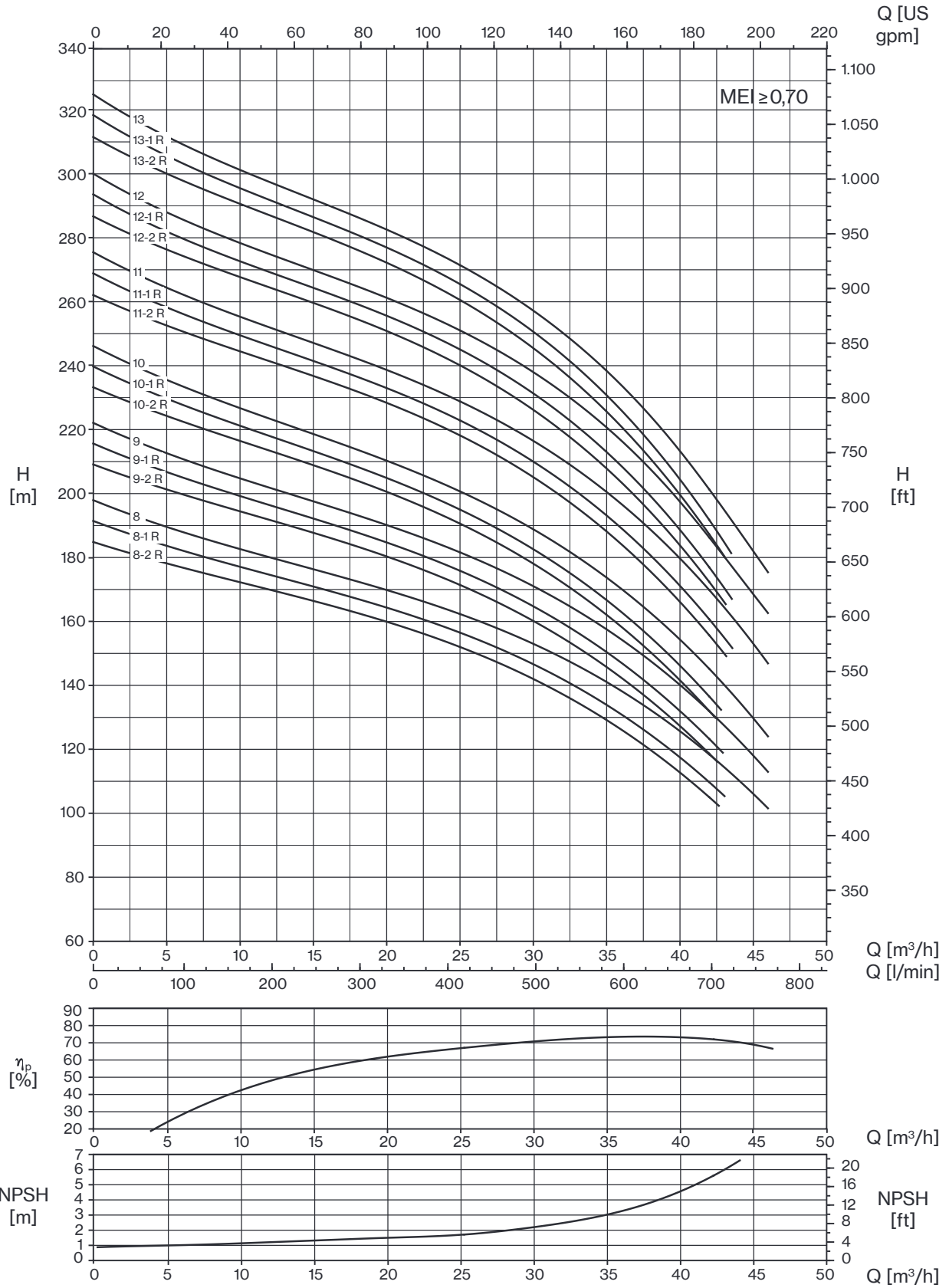

50 HS/HX

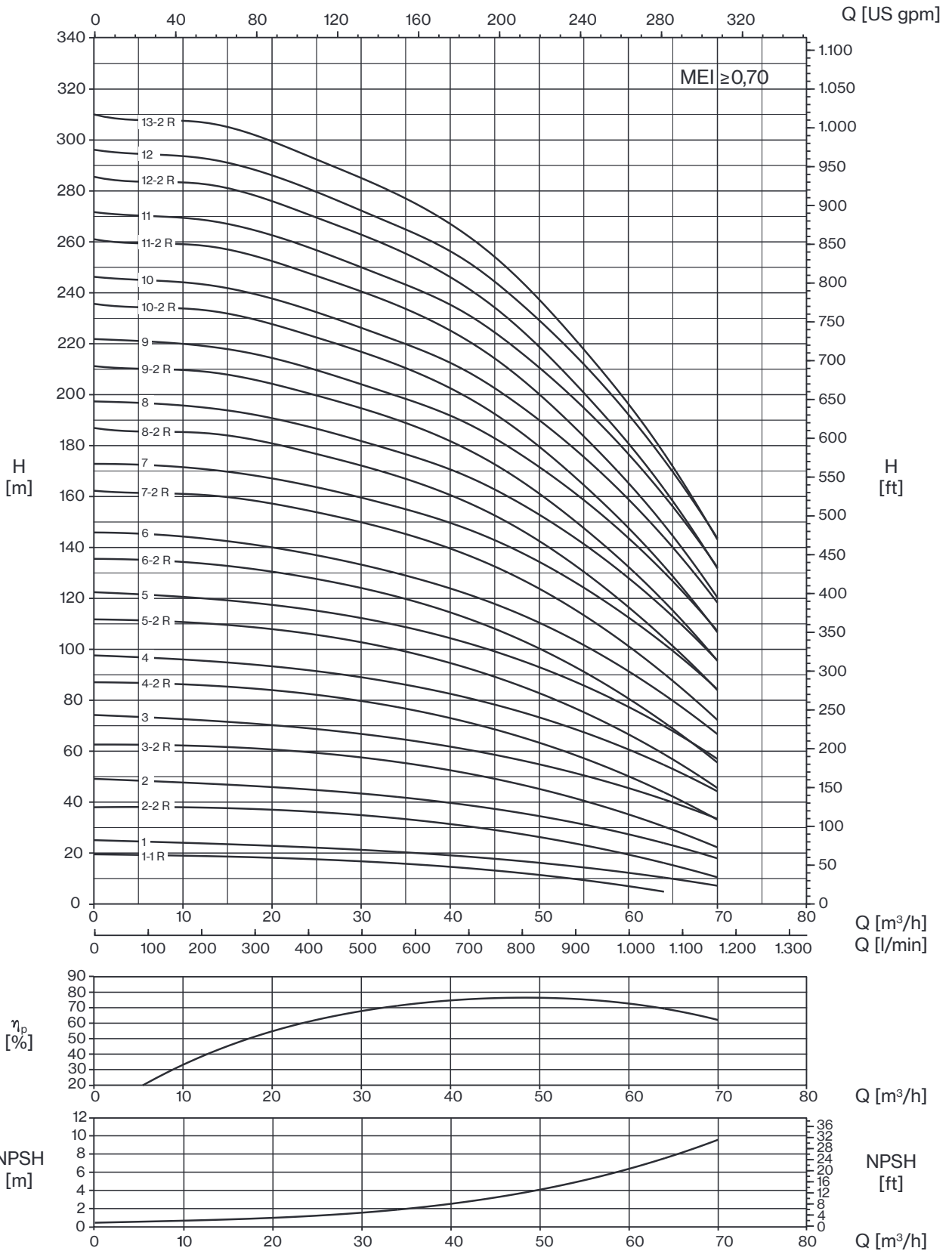

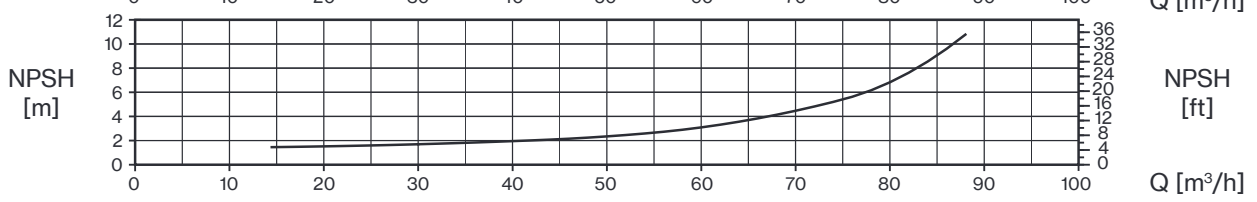
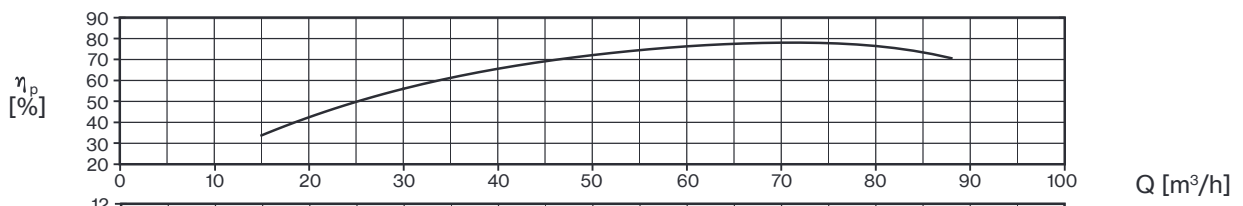
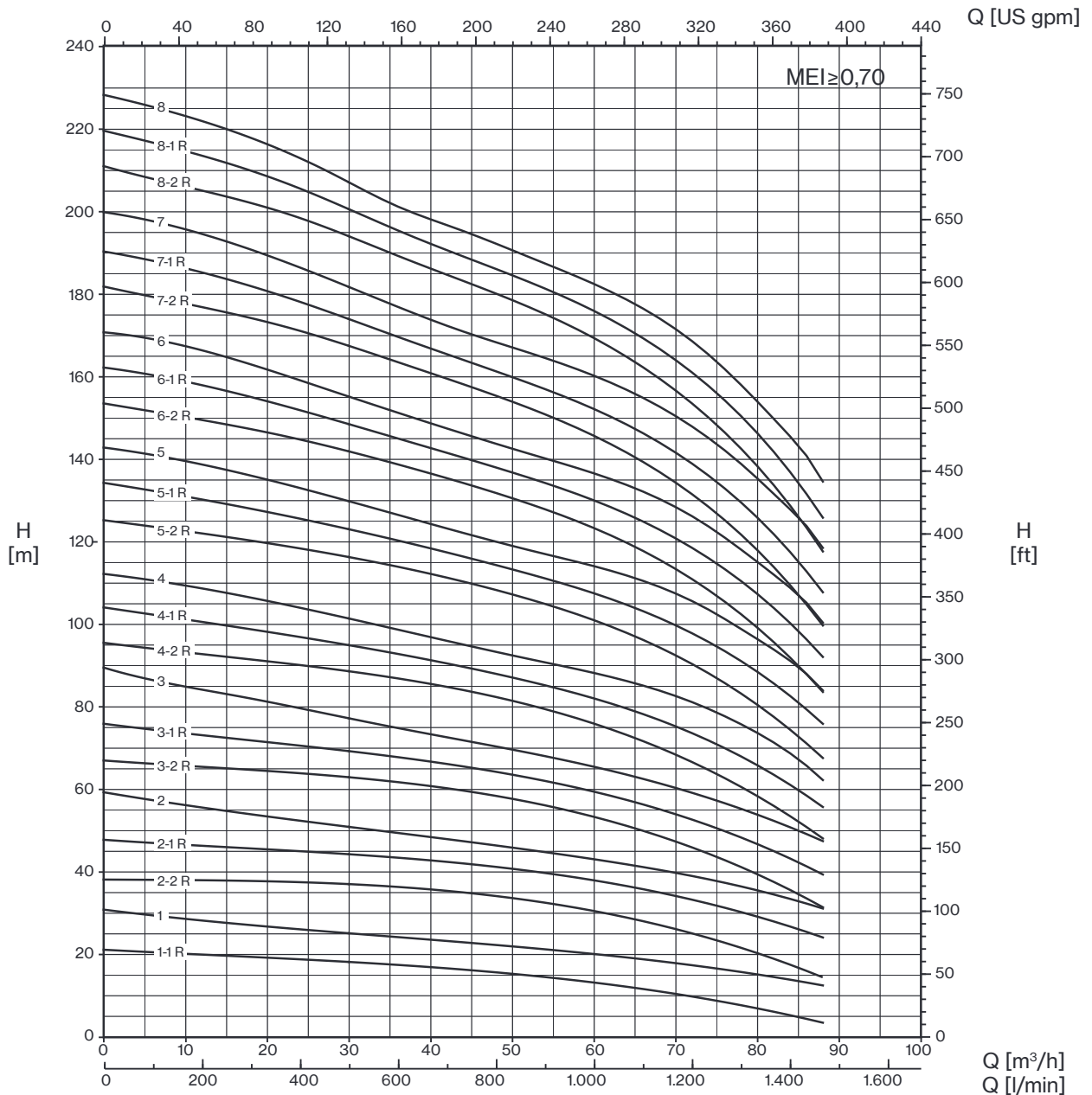

90 HS/HX

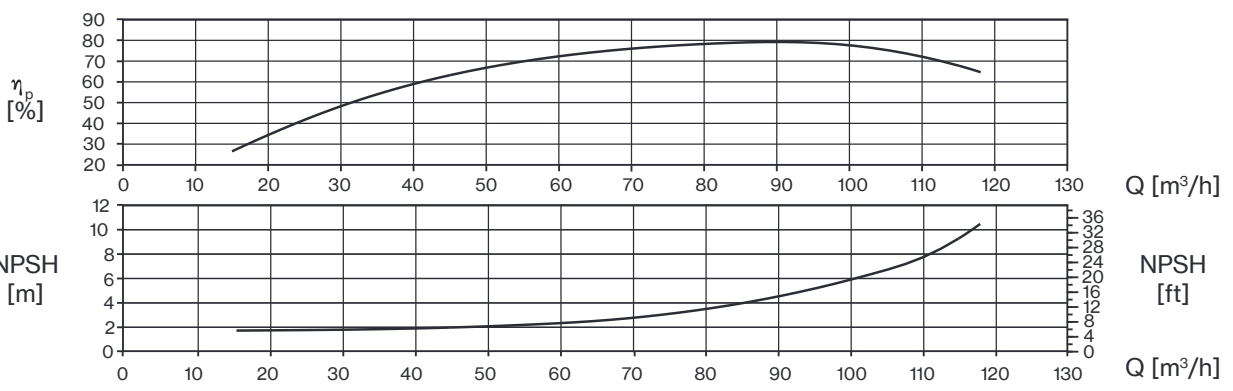
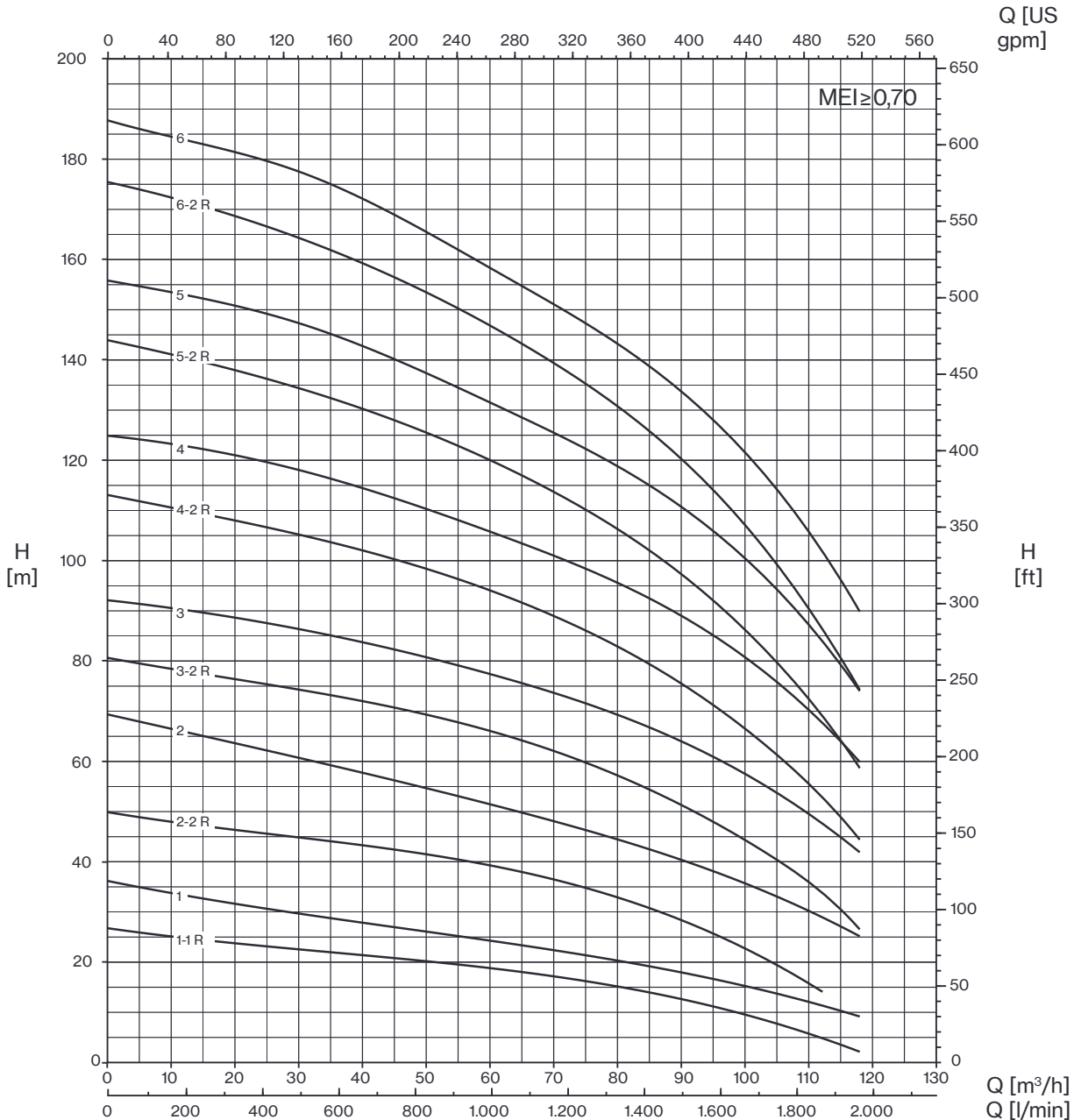

35 HS/HX

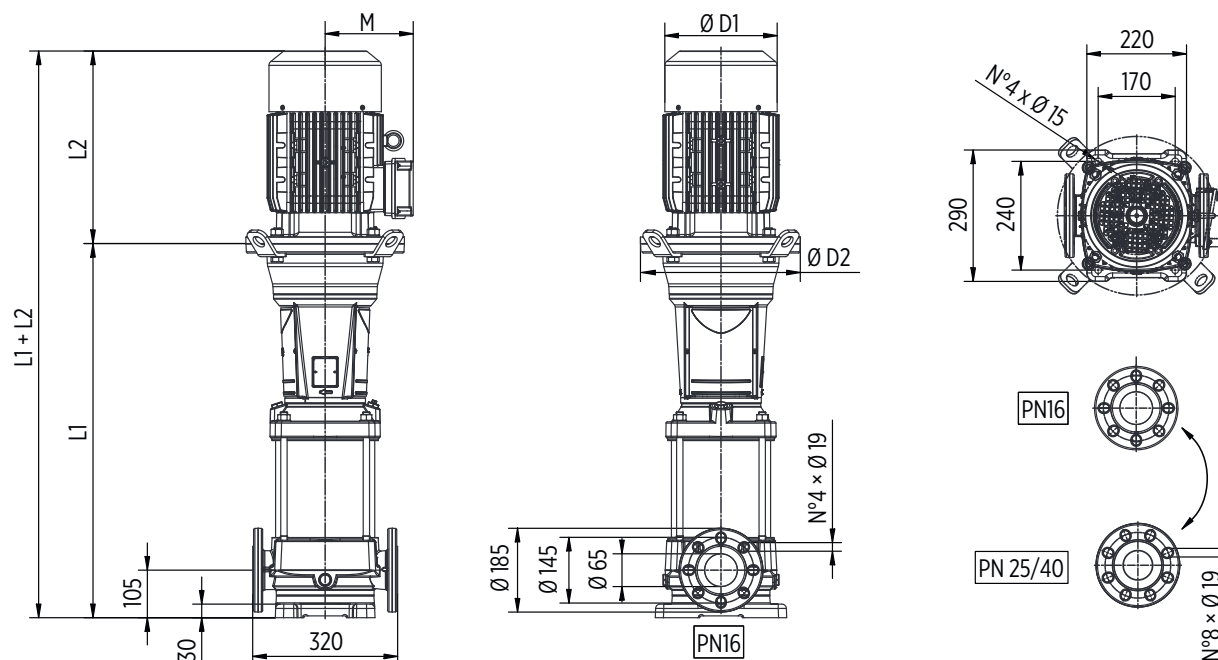

Round flanges on body type PN25/40: the pump is supplied without counterflanges (optional accessories, including bolts and joints)

TYPE	MOTOR		DIMENSIONS (mm)						Kg		
	kW	Dim	L1	L2	M	D1	D2	L1+L2	Pump	Motor	Electric Pump
U 35...-300/1 T	2,2	90	431	308	145	177	170	739	48,5	26	74,5
U 35...-550/2-2R T	4	112	513	350	177	220	170	863	52	43	95
U 35...-550/2-1R T	4	112	513	350	177	220	170	863	52	43	95
U 35...-750/2 T	5,5	132	724	400	197	256	300	1124	72,5	66	138,5
U 35...-750/3-2R T	5,5	132	806	400	197	256	300	1206	76,5	66	142,5
U 35...-1000/3-1R T	7,5	132	806	400	197	256	300	1206	76,5	73	149,5
U 35...-1000/3 T	7,5	132	806	400	197	256	300	1206	76,5	73	149,5
U 35...-1000/4-2R T	7,5	132	888	400	197	256	300	1288	80,5	73	153,5
U 35...-1500/4-1R T	11	160	908	503	255	315	350	1411	84	120	204
U 35...-1500/4 T	11	160	908	503	255	315	350	1411	84	120	204
U 35...-1500/5-2R T	11	160	991	503	255	315	350	1494	88	120	208
U 35...-1500/5-1R T	11	160	991	503	255	315	350	1494	88	120	208
U 35...-2000/5 T	15	160	991	503	255	315	350	1494	88	132	220
U 35...-2000/6-2R T	15	160	1073	503	255	315	350	1576	92	132	224
U 35...-2000/6-1R T	15	160	1073	503	255	315	350	1576	92	132	224
U 35...-2000/6 T	15	160	1073	503	255	315	350	1576	92	132	224
U 35...-2000/7-2R T	15	160	1155	503	255	315	350	1658	96	132	228
U 35...-2000/7-1R T	15	160	1155	503	255	315	350	1658	96	132	228
U 35...-2500/7 T	18,5	160	1155	598	252	315	350	1753	96	150	246
U 35...-2500/8-2R T	18,5	160	1237	598	252	315	350	1835	100	150	250
U 35...-2500/8-1R T	18,5	160	1237	598	252	315	350	1835	100	150	250
U 35...-2500/8 T	18,5	160	1237	598	252	315	350	1835	100	150	250
U 35...-3000/9-2R T	22	180	1319	620	270	360	350	1939	103,5	205	308,5
U 35...-3000/9-1R T	22	180	1319	620	270	360	350	1939	103,5	205	308,5
U 35...-3000/9 T	22	180	1319	620	270	360	350	1939	103,5	205	308,5
U 35...-3000/10-2R T	22	180	1401	620	270	360	350	2021	107,5	205	312,5
U 35...-3000/10-1R T	22	180	1401	620	270	360	350	2021	107,5	205	312,5
U 35...-4000/10 T	30	200	1406	661	303	400	400	2067	111	250	361
U 35...-4000/11-2R T	30	200	1488	661	303	400	400	2149	115	250	365
U 35...-4000/11-1R T	30	200	1488	661	303	400	400	2149	115	250	365
U 35...-4000/11 T	30	200	1488	661	303	400	400	2149	115	250	365
U 35...-4000/12-2R T	30	200	1570	661	303	400	400	2231	119	250	369
U 35...-4000/12-1R T	30	200	1570	661	303	400	400	2231	119	250	369
U 35...-4000/12 T	30	200	1570	661	303	400	400	2231	119	250	369
U 35...-4000/13-2R T	30	200	1652	661	303	400	400	2313	122,5	250	372,5
U 35...-4000/13-1R T	30	200	1652	661	303	400	400	2313	122,5	250	372,5
U 35...-4000/13 T	30	200	1652	661	303	400	400	2313	122,5	250	372,5



50 HS/HX

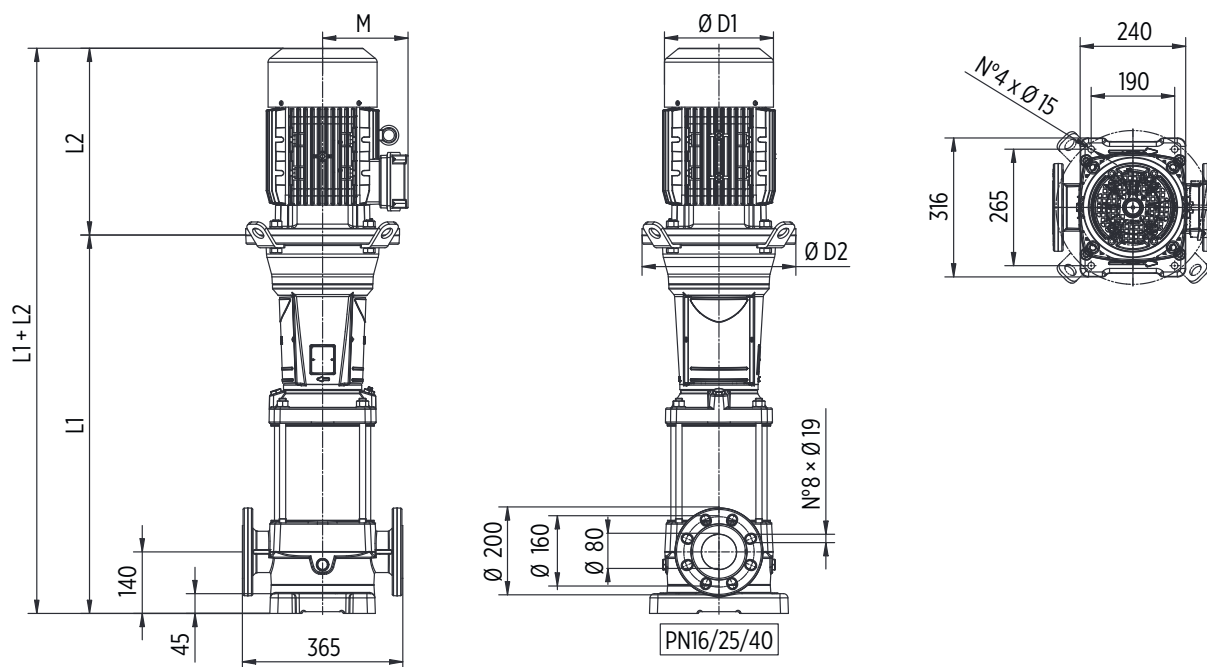

Round flanges on body type PN25/40: the pump is supplied without counterflanges (optional accessories, including bolts and joints)

TYPE	MOTOR		DIMENSIONS (mm)						Kg		
	kW	Dim	L1	L2	M	D1	D2	L1+L2	Pump	Motor	Electric Pump
U 50...-400/1-1R T	3	100	466	333	157	205	170	799	54	35	89
U 50...-550/1 T	4	112	466	350	177	220	170	816	54	43	97
U 50...-750/2-2R T	5,5	132	759	400	197	256	300	1159	78,5	66	144,5
U 50...-1000/2 T	7,5	132	759	400	197	256	300	1159	78,5	73	151,5
U 50...-1500/3-2R T	11	160	861	503	255	315	350	1364	85,5	120	205,5
U 50...-1500/3 T	11	160	861	503	255	315	350	1364	85,5	120	205,5
U 50...-2000/4-2R T	15	160	943	503	255	315	350	1446	89,5	132	221,5
U 50...-2000/4 T	15	160	943	503	255	315	350	1446	89,5	132	221,5
U 50...-2500/5-2R T	18,5	160	1026	598	252	315	350	1624	93,5	150	243,5
U 50...-2500/5 T	18,5	160	1026	598	252	315	350	1624	93,5	150	243,5
U 50...-3000/6-2R T	22	180	1108	620	270	360	350	1728	97,5	205	302,5
U 50...-3000/6 T	22	180	1108	620	270	360	350	1728	97,5	205	302,5
U 50...-4000/7-2R T	30	200	1195	661	303	400	400	1856	104,5	250	354,5
U 50...-4000/7 T	30	200	1195	661	303	400	400	1856	104,5	250	354,5
U 50...-4000/8-2R T	30	200	1277	661	303	400	400	1938	108,5	250	358,5
U 50...-4000/8 T	30	200	1277	661	303	400	400	1938	108,5	250	358,5
U 50...-5000/9-2R T	37	200	1359	661	303	400	400	2020	112,5	270	382,5
U 50...-5000/9 T	37	200	1359	661	303	400	400	2020	112,5	270	382,5
U 50...-5000/10-2R T	37	200	1441	661	303	400	400	2102	116,5	270	386,5
U 50...-5000/10 T	37	200	1441	661	303	400	400	2102	116,5	270	386,5
U 50...-6000/11-2R T	45	225	1523	710	312	450	450	2233	122,5	315	437,5
U 50...-6000/11 T	45	225	1523	710	312	450	450	2233	122,5	315	437,5
U 50...-6000/12-2R T	45	225	1605	710	312	450	450	2315	126,5	315	441,5
U 50...-6000/12 T	45	225	1605	710	312	450	450	2315	126,5	315	441,5
U 50...-6000/13-2R T	45	225	1687	710	312	450	450	2397	130,5	315	445,5



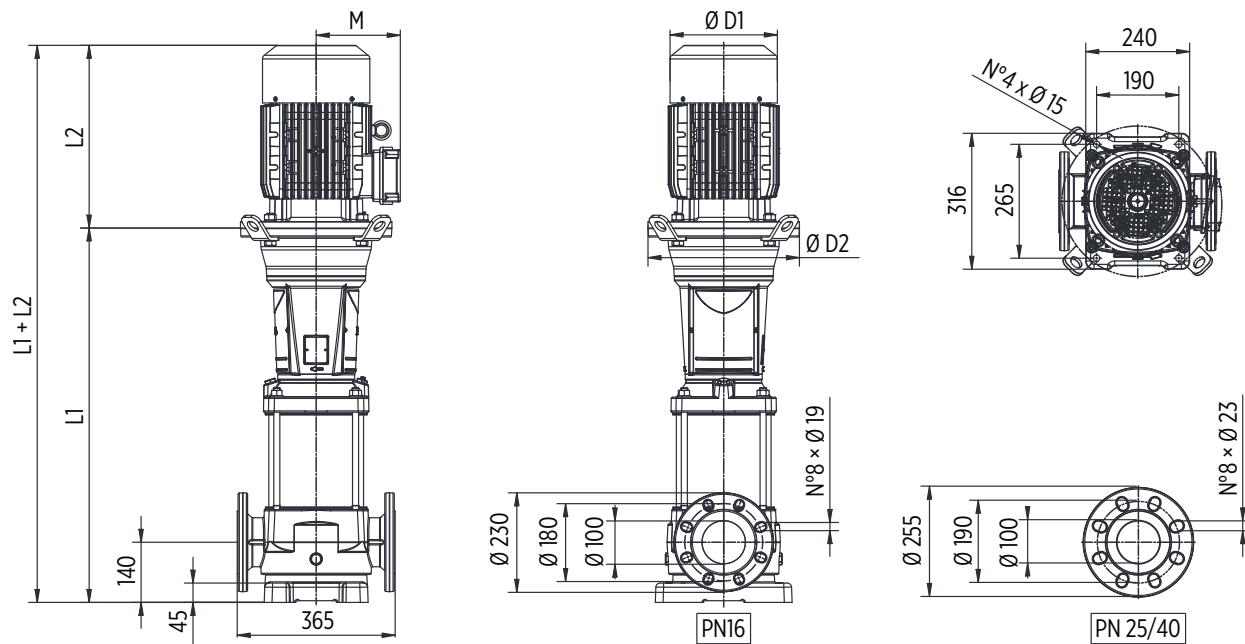

Round flanges on body type PN25/40: the pump is supplied without counterflanges (optional accessories, including bolts and joints)

TYPE	MOTOR		DIMENSIONS (mm)						Kg		
	kW	Dim	L1	L2	M	D1	D2	L1+L2	Pump	Motor	Electric Pump
U 75...-550/1-1R T	4	112	526	350	177	220	170	876	60	43	103
U 75...-750/1 T	5,5	132	737	400	197	256	300	1137	80,5	66	146,5
U 75...-1000/2-2R T	7,5	132	829	400	197	256	300	1229	85	73	158
U 75...-1500/2-1R T	11	160	849	503	255	315	350	1352	88,5	120	208,5
U 75...-1500/2 T	11	160	849	503	255	315	350	1352	88,5	120	208,5
U 75...-2000/3-2R T	15	160	941	503	255	315	350	1444	93	132	225
U 75...-2000/3-1R T	15	160	941	503	255	315	350	1444	93	132	225
U 75...-2500/3 T	18,5	160	941	598	252	315	350	1539	93	150	243
U 75...-2500/4-2R T	18,5	160	1033	598	252	315	350	1631	97,5	150	247,5
U 75...-3000/4-1R T	22	180	1033	620	270	360	350	1653	97	205	302
U 75...-3000/4 T	22	180	1033	620	270	360	350	1653	97	205	302
U 75...-4000/5-2R T	30	200	1131	661	303	400	400	1792	105	250	355
U 75...-4000/5-1R T	30	200	1131	661	303	400	400	1792	105	250	355
U 75...-4000/5 T	30	200	1131	661	303	400	400	1792	105	250	355
U 75...-4000/6-2R T	30	200	1223	661	303	400	400	1884	109,5	250	359,5
U 75...-5000/6-1R T	37	200	1223	661	303	400	400	1884	109,5	270	379,5
U 75...-5000/6 T	37	200	1223	661	303	400	400	1884	109,5	270	379,5
U 75...-5000/7-2R T	37	200	1315	661	303	400	400	1976	113,5	270	383,5
U 75...-5000/7-1R T	37	200	1315	661	303	400	400	1976	113,5	270	383,5
U 75...-6000/7 T	45	225	1315	710	312	450	450	2025	116	315	431
U 75...-6000/8-2R T	45	225	1407	710	312	450	450	2117	120,5	315	435,5
U 75...-6000/8-1R T	45	225	1407	710	312	450	450	2117	120,5	315	435,5
U 75...-6000/8 T	45	225	1407	710	312	450	450	2117	120,5	315	435,5

90 HS/HX

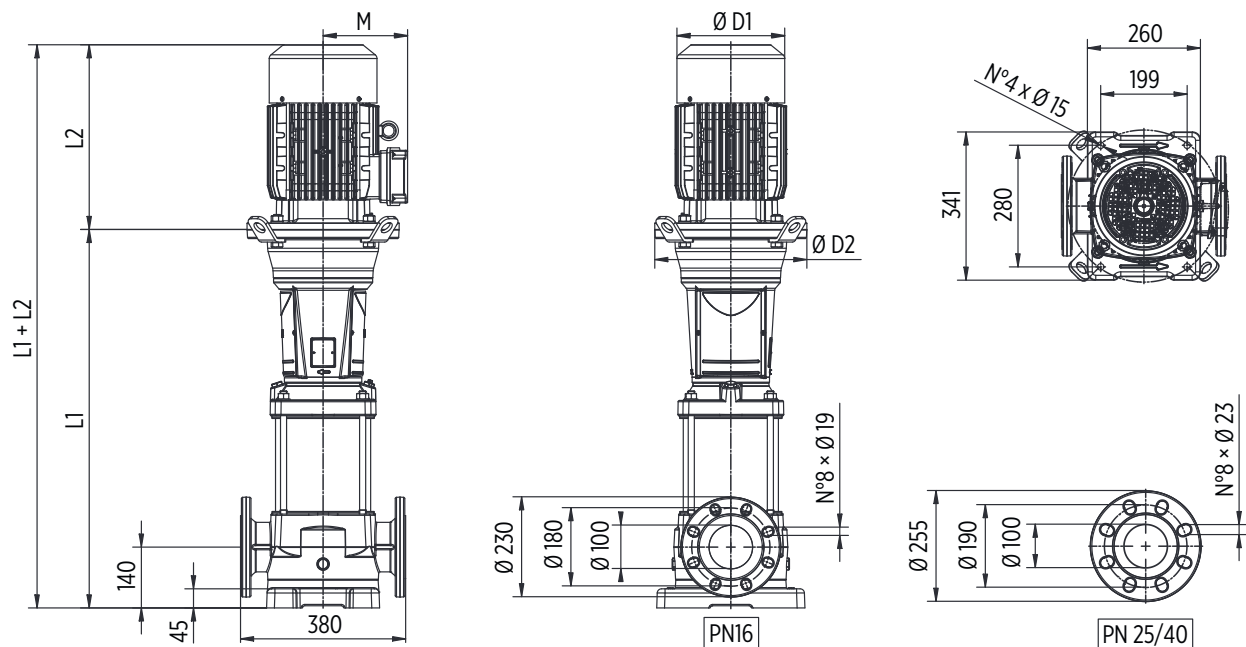



Round flanges on body type PN25/40: the pump is supplied without counterflanges (optional accessories, including bolts and joints)

TYPE	MOTOR		DIMENSIONS (mm)						Kg		
	kW	Dim	L1	L2	M	D1	D2	L1+L2	Pump	Motor	Electric Pump
U 90...-750/1-1R T	5,5	132	737	400	197	256	300	1137	82	66	148
U 90...-1000/1 T	7,5	132	737	400	197	256	300	1137	82	73	155
U 90...-1500/2-2R T	11	160	849	503	255	315	350	1352	89	120	209
U 90...-2000/2 T	15	160	849	503	255	315	350	1352	89	132	221
U 90...-2500/3-2R T	18,5	160	941	598	252	315	350	1539	93	150	243
U 90...-3000/3 T	22	180	941	620	270	360	350	1561	92,5	205	297,5
U 90...-4000/4-2R T	30	200	1038	661	303	400	400	1699	99,5	250	349,5
U 90...-4000/4 T	30	200	1038	661	303	400	400	1699	99,5	250	349,5
U 90...-5000/5-2R T	37	200	1131	661	303	400	400	1792	103	270	373
U 90...-5000/5 T	37	200	1131	661	303	400	400	1792	103	270	373
U 90...-6000/6-2R T	45	225	1223	710	312	450	450	1933	109	315	424
U 90...-6000/6 T	45	225	1223	710	312	450	450	1933	109	315	424



ULTRA HS-HX Serie-Mechanical seal and bearings

CARTRIDGE MECHANICAL SEAL	PUMP MODEL	SHAFT Ø		STANDARD MATERIAL	OPTIONAL		
	U18-100/1T, U18-200/2T, U18-300/3T, U18-400/4T, U18-550/5T, U18-750/6T, U18-750/7T, U18-1000/8T, U18-1000/9T, U18-1500/10T, U18-1500/11T, U18-1500/12T, U18-1500/13T, U18-1500/14T, U18-2000/15T, U18-2000/16T, U18-2000/17T, U22-150/1T, U22-300/2T, U22-400/3T, U22-550/4T, U22-750/5T, U22-1000/6T, U22-1000/7T, U22-1500/8T, U22-1500/9T, U22-1500/10T, U22-2000/11T, U22-2000/12T, U22-2000/13T	16mm	Rotating face Stationary face Elastomer	SiC Graphite EPDM	SiC Graphite FKM	SiC SiC EPDM	SiC SiC FKM
	U35-300/1T, U35-550/2-2RT, U35-550/2-1RT, U35-750/2T, U35-750/3-2RT, U35-1000/3-1RT, U35-1000/3T, U35-1000/4-2RT, U35-1500/4-1RT, U35-1500/4T, U35-1500/5-2RT, U35-1500/5-1RT, U35-2000/5T, U35-2000/6-2RT, U35-2000/6-1RT, U35-2000/6T, U35-2000/7-2RT, U35-2000/7-1RT, U35-2500/7T, U35-2500/8-2RT, U35-2500/8-1RT, U35-2500/8T, U35-3000/9-2RT, U35-3000/9-1RT, U35-3000/9T, U35-3000/10-2RT, U35-3000/10-1RT, U35-4000/10T, U35-4000/11-2RT, U35-4000/11-1RT, U35-4000/11T, U35-4000/12-2RT, U35-4000/12-1RT, U35-4000/12T, U35-4000/13-2RT, U35-4000/13-1RT, U35-4000/13T, U50-400/1-1RT, U50-550/1T, U50-750/2-2RT, U50-1000/2T, U50-1500/3-2RT, U50-1500/3T, U50-2000/4-2RT, U50-2000/4T, U50-2500/5-2RT, U50-2500/5T, U50-3000/6-2RT, U50-3000/6T, U50-4000/7-2RT, U50-4000/7T, U50-4000/8-2RT, U50-4000/8T, U50-5000/9-2RT, U50-5000/9T, U50-5000/10-2RT, U50-5000/10T, U50-6000/11-2RT, U50-6000/11T, U50-6000/12-2RT, U50-6000/12T, U50-6000/13-2RT, U75-550/1-1RT, U75-750/1T, U75-1000/2-2RT, U75-1500/2-1RT, U75-1500/2T, U75-2000/3-2RT, U75-2000/3-1RT, U75-2500/3T, U75-2500/4-2RT, U75-3000/4-1RT, U75-3000/4T, U75-4000/5-2RT, U75-4000/5-1RT, U75-4000/5T, U75-4000/6-2RT, U75-5000/6-1RT, U75-5000/6T, U75-5000/7-2RT, U75-5000/7-1RT, U75-6000/7T, U75-6000/8-2RT, U75-6000/8-1RT, U75-6000/8T, U90-750/1-1RT, U90-1000/1T, U90-1500/2-2RT, U90-2000/2T, U90-2500/3-2RT, U90-3000/3T, U90-4000/4-2RT, U90-4000/4T, U90-5000/5-2RT, U90-5000/5T, U90-6000/6-2RT, U90-6000/6T	22mm / Balanced seal	Rotating face Stationary face Elastomer	SiC Graphite EPDM	SiC Graphite FKM	SiC SiC EPDM	SiC SiC FKM

BEARINGS	PUMP MODEL	PUMP THRUST BEARING		MOTOR BEARING	
	U18-100/1T, U22-150/1T	-	-	6204-ZZ C3	6204-ZZ C3
	U18-200/2T, U18-300/3T, U22-300/2T, U35-300/1T	-	-	6205-ZZ C3	6205-ZZ C3
	U18-400/4T, U18-550/5T, U22-400/3T, U22-550/4T, U35-550/2-2RT, U35-550/2-1RT, U50-400/1-1RT, U50-550/1T, U75-550/1-1RT	-	-	6206-ZZ C3	6206-ZZ C3
	U18-750/6T, U18-750/7T, U18-1000/8T, U18-1000/9T, U22-750/5T, U22-1000/6T, U22-1000/15T, U35-750/2T, U35-750/3-2RT, U35-1000/3-1RT, U35-1000/3T, U35-1000/4-2RT, U50-750/2-2RT, U50-1000/2T, U75-750/1T, U75-1000/2-2RT, U90-750/1-1RT, U90-1000/1T	6212 ZZ	-	6208-ZZ C3	6208-ZZ C3
	U18-1500/10T, U18-1500/11T, U18-1500/12T, U18-1500/13T, U18-1500/14T, U18-2000/15T, U18-2000/16T, U18-2000/17T, U22-1500/8T, U22-1500/9T, U22-1500/10T, U22-2000/11T, U22-2000/12T, U22-2000/13T, U22-2000/14T, U22-2500/15T, U22-2500/16T, U22-2500/17T, U35-1500/4-1RT, U35-1500/4T, U35-1500/5-2RT, U35-1500/5-1RT, U50-1500/3-2RT, U50-1500/3T, U75-1500/2-1RT, U75-1500/2T, U90-1500/2-2RT	6212 ZZ	7212 BEP	6309-ZZ C3	6309-ZZ C3
	U35-2000/5T, U35-2000/6-2RT, U35-2000/6-1RT, U35-2000/6T, U35-2000/7-2RT, U35-2000/7-1RT, U35-2500/7T, U35-2500/8-2RT, U35-2500/8-1RT, U35-2500/8T, U50-2000/4-2RT, U50-2000/4T, U50-2500/5-2RT, U50-2500/5T, U75-2000/3-2RT, U75-2000/3-1RT, U75-2500/3T, U75-2500/4-2RT, U90-2000/2T, U90-2500/3-2RT	6212 ZZ	7212 BEP	6311-ZZ C3	6311-ZZ C3
	U35-3000/9-2RT, U35-3000/9-1RT, U35-3000/9T, U35-3000/10-2RT, U35-3000/10-1RT, U50-3000/6-2RT, U50-3000/6T, U75-3000/4-1RT, U75-3000/4T, U90-3000/3T	6214 ZZ	7214 BEP	6312-ZZ C3	6312-ZZ C3
	U35-4000/10T, U35-4000/11-2RT, U35-4000/11-1RT, U35-4000/11T, U35-4000/12-2RT, U35-4000/12-1RT, U35-4000/12T, U35-4000/13-2RT, U35-4000/13-1RT, U35-4000/13T, U50-4000/7-2RT, U50-4000/7-1RT, U50-4000/7T, U50-4000/8-2RT, U50-4000/8T, U50-5000/9-2RT, U50-5000/9T, U50-5000/10-2RT, U50-5000/10T, U75-4000/5-2RT, U75-4000/5-1RT, U75-4000/5T, U75-4000/6-2RT, U75-5000/6-1RT, U75-5000/6T, U75-5000/7-2RT, U75-5000/7-1RT, U90-4000/4-2RT, U90-4000/4T, U90-5000/5-2RT, U90-5000/5T	6214 ZZ	7214 BEP	6313-ZZ C3	6313-ZZ C3
	U50-6000/11-2RT, U50-6000/11T, U50-6000/12-2RT, U50-6000/12T, U50-6000/13-2RT, U75-6000/7T, U75-6000/8-2RT, U75-6000/8-1RT, U75-6000/8T, U90-6000/6-2RT, U90-6000/6T				



ULTRA+VSD

Vertical booster pump with variable speed



DESCRIPTION

Horizontal pump of ULTRA series provided with variable speed drive EPIC or IPFC. This booster pump assure the desired pressure regardless changes on flow demand making it suitable for low or missing pressure in residential systems and industrial applications. It is required the installation of a membrane tank downstream the system.

FEATURES

- EPIC or IPFC variable speed drive
- Vertical pump of ULTRA series
- Pressure sensor wired to the vsd
- Cable with plug for EPIC vsd only

FUNCTIONING

If the pressure in the network drops the pump will starts and gradually speeds up to provide with the set pressure. When the water demand decreases, the pressure will rise causing the pump speed to slow down and eventually to stop the pump if demand ceases. The pump will remain on standby waiting to start at the next water demand.

SELECTION

The table below shows the vertical ULTRA pump models available for the assembly with EPIC or IPFC. Consult the catalog at the ULTRA series for pump specifics and characteristic curves.



PUMP								VSD		
TYPE	MODEL	Version						TYPE	Power system	
		V	SV	L	SL/SLX	LG	SLG/SLGX		in	out
U 3	100/5T	■	■	■	■	-	-	EPIC	1-230	3-230
		■	■	■	■	-	-	IPFC109	1-230	3-230
		■	■	■	■	-	-	IPFC306	3-400	3-400
	120/6T	■	■	■	■	-	-	EPIC	1-230	3-230
		■	■	■	■	-	-	IPFC109	1-230	3-230
		■	■	■	■	-	-	IPFC306	3-400	3-400
	150/7T	■	■	■	■	-	-	EPIC	1-230	3-230
		■	■	■	■	-	-	IPFC109	1-230	3-230
		■	■	■	■	-	-	IPFC306	3-400	3-400
	180/8T	■	■	■	■	-	-	EPIC	1-230	3-230
		■	■	■	■	-	-	IPFC109	1-230	3-230
		■	■	■	■	-	-	IPFC306	3-400	3-400
	200/9T	■	■	■	■	-	-	EPIC	1-230	3-230
		■	■	■	■	-	-	IPFC109	1-230	3-230
■		■	■	■	-	-	IPFC306	3-400	3-400	
250/10T	■	■	■	■	-	-	EPIC	1-230	3-230	
	■	■	■	■	-	-	IPFC114	1-230	3-230	
	■	■	■	■	-	-	IPFC306	3-400	3-400	
280/11T	-	■	-	■	-	-	EPIC	1-230	3-230	
	■	■	■	■	-	-	IPFC114	1-230	3-230	
	■	■	■	■	-	-	IPFC306	3-400	3-400	
300/12T	■	■	■	■	-	-	IPFC114	1-230	3-230	
	■	■	■	■	-	-	IPFC306	3-400	3-400	
	-	-	-	-	-	■	IPFC114	1-230	3-230	
350/14T	-	-	-	-	-	■	IPFC306	3-400	3-400	
	-	-	-	-	-	■	IPFC114	1-230	3-230	
	-	-	-	-	-	■	IPFC309	3-400	3-400	
380/16T	-	-	-	-	-	■	IPFC309	3-400	3-400	
	-	-	-	-	-	■	IPFC309	3-400	3-400	
	-	-	-	-	-	■	IPFC309	3-400	3-400	
U 5	120/4T	■	■	■	■	-	-	EPIC	1-230	3-230
		■	■	■	■	-	-	IPFC109	1-230	3-230
		■	■	■	■	-	-	IPFC306	3-400	3-400
	150/5T	■	■	■	■	-	-	EPIC	1-230	3-230
		■	■	■	■	-	-	IPFC109	1-230	3-230
		■	■	■	■	-	-	IPFC306	3-400	3-400
	180/6T	■	■	■	■	-	-	EPIC	1-230	3-230
		■	■	■	■	-	-	IPFC109	1-230	3-230
		■	■	■	■	-	-	IPFC306	3-400	3-400
	200/7T	■	■	■	■	-	-	EPIC	1-230	3-230
		■	■	■	■	-	-	IPFC109	1-230	3-230
		■	■	■	■	-	-	IPFC306	3-400	3-400
	250/8T	■	■	■	■	-	-	EPIC	1-230	3-230
		■	■	■	■	-	-	IPFC114	1-230	3-230
■		■	■	■	-	-	IPFC306	3-400	3-400	
280/9T	■	■	■	■	-	-	IPFC114	1-230	3-230	
	■	■	■	■	-	-	IPFC306	3-400	3-400	
	■	■	■	■	-	-	IPFC114	1-230	3-230	
300/10T	■	■	■	■	-	-	IPFC306	3-400	3-400	
	■	■	■	■	-	-	IPFC114	1-230	3-230	
	■	■	■	■	-	-	IPFC306	3-400	3-400	
350/11T	■	■	■	■	-	-	IPFC114	1-230	3-230	
	■	■	■	■	-	-	IPFC306	3-400	3-400	
	■	■	■	■	-	-	IPFC309	3-400	3-400	
380/12T	■	■	■	■	-	-	IPFC309	3-400	3-400	
	-	-	-	-	-	■	IPFC309	3-400	3-400	
	-	-	-	-	-	■	IPFC309	3-400	3-400	
400/14T	-	-	-	-	-	■	IPFC309	3-400	3-400	
	-	-	-	-	-	■	IPFC309	3-400	3-400	
	-	-	-	-	-	■	IPFC309	3-400	3-400	
450/16T	-	-	-	-	-	■	IPFC309	3-400	3-400	
	-	-	-	-	-	■	IPFC309	3-400	3-400	
	-	-	-	-	-	■	IPFC309	3-400	3-400	
550/18T	-	-	-	-	-	■	IPFC309	3-400	3-400	
	-	-	-	-	-	■	IPFC309	3-400	3-400	
	-	-	-	-	-	■	IPFC309	3-400	3-400	
600/20T	-	-	-	-	-	■	IPFC311	3-400	3-400	
	-	-	-	-	-	■	IPFC311	3-400	3-400	
	-	-	-	-	-	■	IPFC311	3-400	3-400	



ULTRA+VSD

PUMP								VSD		
TYPE	MODEL	Version						TYPE	Power system	
		V	SV	L	SL/SLX	LG	SLG/SLGX		in	out
U 7	180/4T	■	■	■	■	-	-	EPIC	1-230	3-230
		■	■	■	■	-	-	IPFC109	1-230	3-230
		■	■	■	■	-	-	IPFC306	3-400	3-400
	250/5T	■	■	■	■	-	-	IPFC114	1-230	3-230
		■	■	■	■	-	-	IPFC306	3-400	3-400
	300/6T	■	■	■	■	-	-	IPFC114	1-230	3-230
		■	■	■	■	-	-	IPFC306	3-400	3-400
	350/7T	■	■	■	■	-	-	IPFC114	1-230	3-230
		■	■	■	■	-	-	IPFC306	3-400	3-400
	400/8T	■	■	■	■	-	-	IPFC309	3-400	3-400
	450/9T	■	■	■	■	-	-	IPFC309	3-400	3-400
	550/10T	■	■	■	■	-	-	IPFC311	3-400	3-400
750/12T	-	-	-	-	-	■	IPFC311	3-400	3-400	
800/14T	-	-	-	-	-	■	IPFC314	3-400	3-400	
900/16T	-	-	-	-	-	■	IPFC314	3-400	3-400	
950/18T	-	-	-	-	-	■	IPFC318	3-400	3-400	
1000/20T	-	-	-	-	-	■	IPFC318	3-400	3-400	
U 9	200/4T	■	■	■	■	-	-	EPIC	1-230	3-230
		■	■	■	■	-	-	IPFC109	1-230	3-230
		■	■	■	■	-	-	IPFC306	3-400	3-400
	250/5T	■	■	■	■	-	-	EPIC	1-230	3-230
		■	■	■	■	-	-	IPFC114	1-230	3-230
	300/6T	■	■	■	■	-	-	IPFC306	3-400	3-400
		■	■	■	■	-	-	IPFC114	1-230	3-230
	400/7T	■	-	■	-	-	-	IPFC306	3-400	3-400
		■	-	■	-	-	-	IPFC309	3-400	3-400
	450/8T	■	■	■	■	-	-	IPFC309	3-400	3-400
	500/9T	■	■	■	■	-	-	IPFC309	3-400	3-400
	550/10T	■	■	■	■	-	-	IPFC311	3-400	3-400
750/12T	-	-	-	-	-	■	IPFC311	3-400	3-400	
800/14T	-	-	-	-	-	■	IPFC314	3-400	3-400	
900/16T	-	-	-	-	-	■	IPFC314	3-400	3-400	
950/18T	-	-	-	-	-	■	IPFC318	3-400	3-400	
1000/20T	-	-	-	-	-	■	IPFC318	3-400	3-400	



PUMP									VSD		
TYPE	MODEL	Version							TYPE	Power system	
		V	SV	L	SL/SLX	LG	HS	HX		in	out
U 18	100/1T	-	-	-	-	-	-	■	IPFC109	1-230	3-230
		-	-	-	-	-	-	■	IPFC306	3-400	3-400
	200/2T	-	-	-	-	-	-	■	IPFC109	1-230	3-230
		-	-	-	-	-	-	■	IPFC306	3-400	3-400
	250/3T	■	■	■	■	-	-	-	EPIC	1-230	3-230
		■	■	■	■	-	-	-	IPFC114	1-230	3-230
		■	■	■	■	-	-	-	IPFC306	3-400	3-400
	300/3T	-	-	-	-	-	-	■	IPFC114	1-230	3-230
		-	-	-	-	-	-	■	IPFC306	3-400	3-400
	400/4T	■	■	■	■	-	-	■	IPFC114	1-230	3-230
		■	■	■	■	-	-	■	IPFC306	3-400	3-400
	450/5T	■	■	■	■	-	-	-	IPFC309	3-400	3-400
	550/5T	-	-	-	-	-	-	■	IPFC309	3-400	3-400
	550/6T	■	■	■	■	-	-	-	IPFC311	3-400	3-400
	750/6T	-	-	-	-	-	-	■	IPFC311	3-400	3-400
	750/7T	-	-	-	-	-	-	■	IPFC311	3-400	3-400
	750/8T	■	■	■	■	-	-	-	IPFC314	3-400	3-400
	900/9T	■	■	■	■	-	-	-	IPFC318	3-400	3-400
	920/10T	-	-	-	-	■	-	-	IPFC318	3-400	3-400
	1000/8T	-	-	-	-	-	-	■	IPFC314	3-400	3-400
1000/9T	-	-	-	-	-	-	■	IPFC314	3-400	3-400	
1000/11T	-	-	-	-	■	-	-	IPFC318	3-400	3-400	
1500/10T	-	-	-	-	-	-	■	IPFC318	3-400	3-400	
1500/11T	-	-	-	-	-	-	■	IPFC318	3-400	3-400	
1500/12T	-	-	-	-	-	-	■	IPFC325	3-400	3-400	
1500/13T	-	-	-	-	-	-	■	IPFC325	3-400	3-400	
1500/14T	-	-	-	-	-	-	■	IPFC325	3-400	3-400	
2000/15T	-	-	-	-	-	-	■	IPFC325	3-400	3-400	
2000/16T	-	-	-	-	-	-	■	IPFC325	3-400	3-400	
2000/17T	-	-	-	-	-	-	■	IPFC330	3-400	3-400	
U 22	200/1T	-	-	-	-	-	-	■	IPFC109	1-230	3-230
		-	-	-	-	-	-	■	IPFC306	3-400	3-400
	300/2T	-	-	-	-	-	-	■	IPFC114	1-230	3-230
		-	-	-	-	-	-	■	IPFC306	3-400	3-400
	400/3T	-	-	-	-	-	-	■	IPFC309	3-400	3-400
	550/4T	-	-	-	-	-	-	■	IPFC311	3-400	3-400
	750/5T	-	-	-	-	-	-	■	IPFC311	3-400	3-400
	1000/6T	-	-	-	-	-	-	■	IPFC314	3-400	3-400
	1000/7T	-	-	-	-	-	-	■	IPFC318	3-400	3-400
	1500/8T	-	-	-	-	-	-	■	IPFC318	3-400	3-400
	1500/9T	-	-	-	-	-	-	■	IPFC325	3-400	3-400
	1500/10T	-	-	-	-	-	-	■	IPFC325	3-400	3-400
	2000/11T	-	-	-	-	-	-	■	IPFC325	3-400	3-400
	2000/12T	-	-	-	-	-	-	■	IPFC325	3-400	3-400
2000/13T	-	-	-	-	-	-	■	IPFC330	3-400	3-400	
2000/14T	-	-	-	-	-	-	■	IPFC330	3-400	3-400	



ULTRA+VSD

		PUMP							VSD		
TYPE	MODEL	Version							TYPE	Power system	
		V	SV	L	SL/SLX	LG	HS	HX		in	out
U 35	300/1T	-	-	-	-	-	■	■	IPFC114	1-230	3-230
		-	-	-	-	-	■	■	IPFC306	3-400	3-400
	550/2-2RT	-	-	-	-	-	■	■	IPFC309	3-400	3-400
	550/2-1RT	-	-	-	-	-	■	■	IPFC309	3-400	3-400
	750/2T	-	-	-	-	-	■	■	IPFC311	3-400	3-400
	750/3-2RT	-	-	-	-	-	■	■	IPFC311	3-400	3-400
	1000/3-1RT	-	-	-	-	-	■	■	IPFC314	3-400	3-400
	1000/3T	-	-	-	-	-	■	■	IPFC314	3-400	3-400
	1000/4-2RT	-	-	-	-	-	■	■	IPFC318	3-400	3-400
	1500/4-1RT	-	-	-	-	-	■	■	IPFC318	3-400	3-400
	1500/4T	-	-	-	-	-	■	■	IPFC325	3-400	3-400
	1500/5-2RT	-	-	-	-	-	■	■	IPFC325	3-400	3-400
	1500/5-1RT	-	-	-	-	-	■	■	IPFC325	3-400	3-400
	2000/5T	-	-	-	-	-	■	■	IPFC325	3-400	3-400
	2000/6-2RT	-	-	-	-	-	■	■	IPFC325	3-400	3-400
	2000/6-1RT	-	-	-	-	-	■	■	IPFC330	3-400	3-400
2000/6T	-	-	-	-	-	■	■	IPFC330	3-400	3-400	
2000/7-2RT	-	-	-	-	-	■	■	IPFC330	3-400	3-400	
2000/7-1RT	-	-	-	-	-	■	■	IPFC330	3-400	3-400	
U 50	400/1-1RT	-	-	-	-	-	■	■	IPFC114	1-230	3-230
		-	-	-	-	-	■	■	IPFC306	3-400	3-400
	550/1T	-	-	-	-	-	■	■	IPFC309	3-400	3-400
	750/2-2RT	-	-	-	-	-	■	■	IPFC311	3-400	3-400
	1000/2T	-	-	-	-	-	■	■	IPFC318	3-400	3-400
	1500/3-2RT	-	-	-	-	-	■	■	IPFC325	3-400	3-400
	1500/3T	-	-	-	-	-	■	■	IPFC318	3-400	3-400
	2000/4-2RT	-	-	-	-	-	■	■	IPFC325	3-400	3-400
2000/4T	-	-	-	-	-	■	■	IPFC330	3-400	3-400	
U 75	550/1-1RT	-	-	-	-	-	■	■	IPFC309	3-400	3-400
	750/1T	-	-	-	-	-	■	■	IPFC311	3-400	3-400
	1000/2-2RT	-	-	-	-	-	■	■	IPFC318	3-400	3-400
	1500/2-1RT	-	-	-	-	-	■	■	IPFC318	3-400	3-400
	1500/2T	-	-	-	-	-	■	■	IPFC325	3-400	3-400
	2000/3-2RT	-	-	-	-	-	■	■	IPFC325	3-400	3-400
	2000/3-1RT	-	-	-	-	-	■	■	IPFC330	3-400	3-400
U 90	750/1-1RT	-	-	-	-	-	■	■	IPFC311	3-400	3-400
	1000/1T	-	-	-	-	-	■	■	IPFC318	3-400	3-400
	1500/2-2RT	-	-	-	-	-	■	■	IPFC325	3-400	3-400
	2000/2T	-	-	-	-	-	■	■	IPFC330	3-400	3-400

