

ULTRA HX



Multistage Vertical



Stainless steel multistage vertical pumps. Suitable for clean non-loaded fluids, pressurizing system, irrigation, drinking and glycol water, water treatment, food industry, heating and air conditioning, washing system.

Construction features

Pump body	EN 1.4401 / AISI 316
Motor bracket	cast iron
Impellers, diffusers, shell, pump shaft	EN 1.4401 / AISI 316
Mechanical seal	silicon carbide-graphite-EPDM
Ambient temperature	max 40 °C
Liquid temperature	-15 ÷ +120 °C (Max 85° for domestic use)
Max operating pressure	max 26 bar
Pump body gasket	EPDM

Motor

2 pole induction motor	3~ 230/400V-50Hz P ≤ 4kW, size B14 V1 3~ 400/690V-50Hz P > 4kW, size B5 V1 IE3 efficiency class
Insulation class	F
Protection degree	IP55



U 18 H X -100/1 T

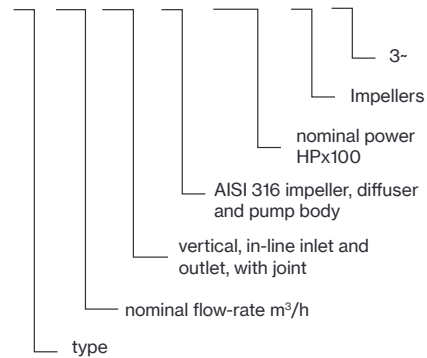

ULTRA 18-22

TYPE	P2		Q (m³/h - l/min - US gpm)											
			0	133,3	150	166,7	183,3	200	216,7	233,3	266,7	300	350	400
3-			0	8	9	10	11	12	13	14	16	18	21	24
			0	35,2	39,6	44,0	48,4	52,8	57,2	61,6	70,3	79,1	92,3	105,5
	HP	kW	H (m)											
U 18HX-100/1 T	1	0,75	13,0	11,7	11,6	11,4	11,1	10,8	10,4	10,1	9,1	7,9	5,6	
U 18HX-200/2 T	2	1,5	27,1	24,3	23,9	23,5	22,9	22,3	21,7	21,1	19,3	17,2	13,1	8,0
U 18HX-300/3 T	3	2,2	41,2	37,4	36,7	36,1	35,3	34,4	33,6	32,7	30,1	27,1	20,8	13,5
U 18HX-400/4 T	4	3	55,1	50,2	49,3	48,5	47,5	46,3	45,2	44,0	40,6	36,6	28,2	18,5
U 18HX-550/5 T	5,5	4	72,3	64,7	63,7	62,6	61,5	60,1	58,5	57,2	53,6	48,7	38,9	27,6
U 18HX-750/6 T	7,5	5,5	88,0	80,1	78,9	77,7	76,4	74,9	73,3	71,7	68,0	62,4	51,3	37,5
U 18HX-750/7 T	7,5	5,5	102,5	93,0	91,5	90,1	88,6	86,8	84,9	83,0	78,6	72,0	59,1	43,0
U 18HX-1000/8 T	10	7,5	116,9	105,9	104,2	102,6	100,8	98,8	96,5	94,4	89,3	81,7	66,9	48,5
U 18HX-1000/9 T	10	7,5	131,2	118,5	116,6	114,8	112,7	110,4	107,9	105,5	99,7	91,1	74,3	53,6
U 18HX-1500/10 T	15	11	147,3	134,1	132,1	130,1	127,9	125,5	122,8	120,2	114,1	104,8	86,3	63,4
U 18HX-1500/11 T	15	11	161,7	147,1	144,9	142,7	140,3	137,6	134,6	131,7	125,0	114,7	94,4	69,2
U 18HX-1500/12 T	15	11	176,2	160,0	157,6	155,2	152,6	149,6	146,3	143,2	135,7	124,5	102,3	74,8
U 18HX-1500/13 T	15	11	190,6	172,9	170,3	167,7	164,8	161,6	158,0	154,6	146,4	134,2	110,1	80,3
U 18HX-1500/14 T	15	11	204,9	185,7	182,9	180,0	176,9	173,4	169,5	165,9	157,0	143,8	117,8	85,7
U 18HX-2000/15 T	20	15	220,7	200,2	197,2	194,2	190,8	187,1	183,0	179,0	169,7	155,7	127,8	93,4
U 18HX-2000/16 T	20	15	235,1	213,1	209,8	206,6	203,0	199,0	194,6	190,4	180,3	165,3	135,6	98,9
U 18HX-2000/17 T	20	15	249,4	225,9	222,4	219,0	215,1	210,9	206,1	201,6	190,9	174,8	143,3	104,2

TYPE	P2		Q (m³/h - l/min - US gpm)											
			0	166,7	183,3	200	216,7	233,3	266,7	300	350	400	433,3	466,7
3-			0	10	11	12	13	14	16	18	21	24	26	28
			0	44,0	48,4	52,8	57,2	61,6	70,3	79,1	92,3	105,5	114,3	123,1
	HP	kW	H (m)											
U 22HX-200/1 T	2	1,1	14,3	12,9	12,8	12,5	12,2	11,9	11,4	10,5	9,0	6,7	4,0	
U 22HX-300/2 T	3	2,2	29,7	26,9	26,6	26,3	26,0	25,5	24,5	23,3	20,7	17,1	13,9	10,6
U 22HX-400/3 T	4	3	45,0	40,9	40,4	39,9	39,2	38,5	37,2	35,5	31,6	25,8	21,5	16,6
U 22HX-550/4 T	5,5	4	62,2	55,7	54,9	54,2	53,7	52,8	50,9	49,0	44,0	36,8	31,1	25,2
U 22HX-750/5 T	7,5	5,5	78,6	70,8	69,9	69,0	68,5	67,4	65,1	62,8	56,9	47,9	41,0	33,5
U 22HX-1000/6 T	10	7,5	94,2	86,2	85,1	84,1	83,2	82,2	79,7	77,3	70,0	59,4	51,3	42,0
U 22HX-1000/7 T	10	7,5	109,5	99,8	98,5	97,4	96,3	95,1	92,2	89,2	80,6	68,2	58,7	47,9
U 22HX-1500/8 T	15	11	126,5	116,1	114,7	113,5	112,3	111,0	107,9	104,8	95,4	81,4	70,7	58,3
U 22HX-1500/9 T	15	11	142,0	130,2	128,6	127,2	125,9	124,4	120,8	117,3	106,7	90,8	78,7	64,8
U 22HX-1500/10 T	15	11	157,5	144,2	142,4	140,8	139,3	137,7	133,6	129,6	117,7	100,1	86,6	71,1
U 22HX-2000/11 T	20	15	174,0	159,4	157,4	155,7	154,1	152,3	147,9	143,5	130,5	111,2	96,4	79,3
U 22HX-2000/12 T	20	15	189,5	173,4	171,2	169,3	167,6	165,5	160,7	155,8	141,6	120,4	104,2	85,6
U 22HX-2000/13 T	20	15	204,9	187,3	184,9	182,8	180,9	178,7	173,4	168,1	152,5	129,5	111,9	91,7
U 22HX-2000/14 T	20	15	220,3	201,1	198,5	196,2	194,1	191,7	186,0	180,2	163,2	138,4	119,4	97,7
U 22HX-2500/15 T	25	18,5	237,4	218,1	215,4	213,1	211,0	208,6	202,6	196,8	179,4	153,1	133,0	109,7
U 22HX-2500/16 T	25	18,5	252,9	232,2	229,4	226,9	224,6	222,0	215,6	209,4	190,7	162,7	141,1	116,3
U 22HX-2500/17 T	25	18,5	268,5	246,3	243,3	240,6	238,2	235,4	228,6	221,9	202,0	172,1	149,2	122,8



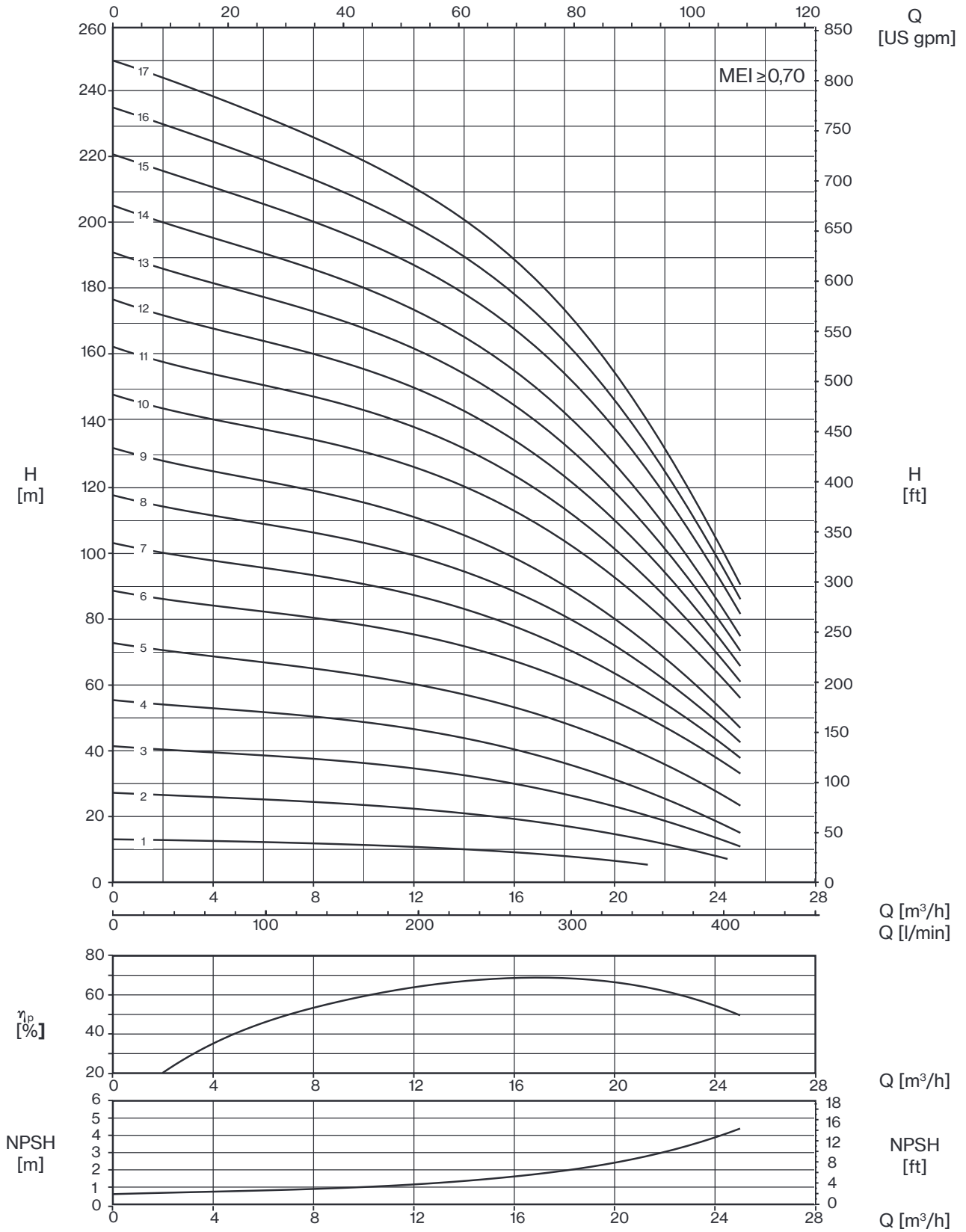

The hydraulic characteristics are guaranteed, according to ISO Standard 9906:2012, grade 3B



22 HX

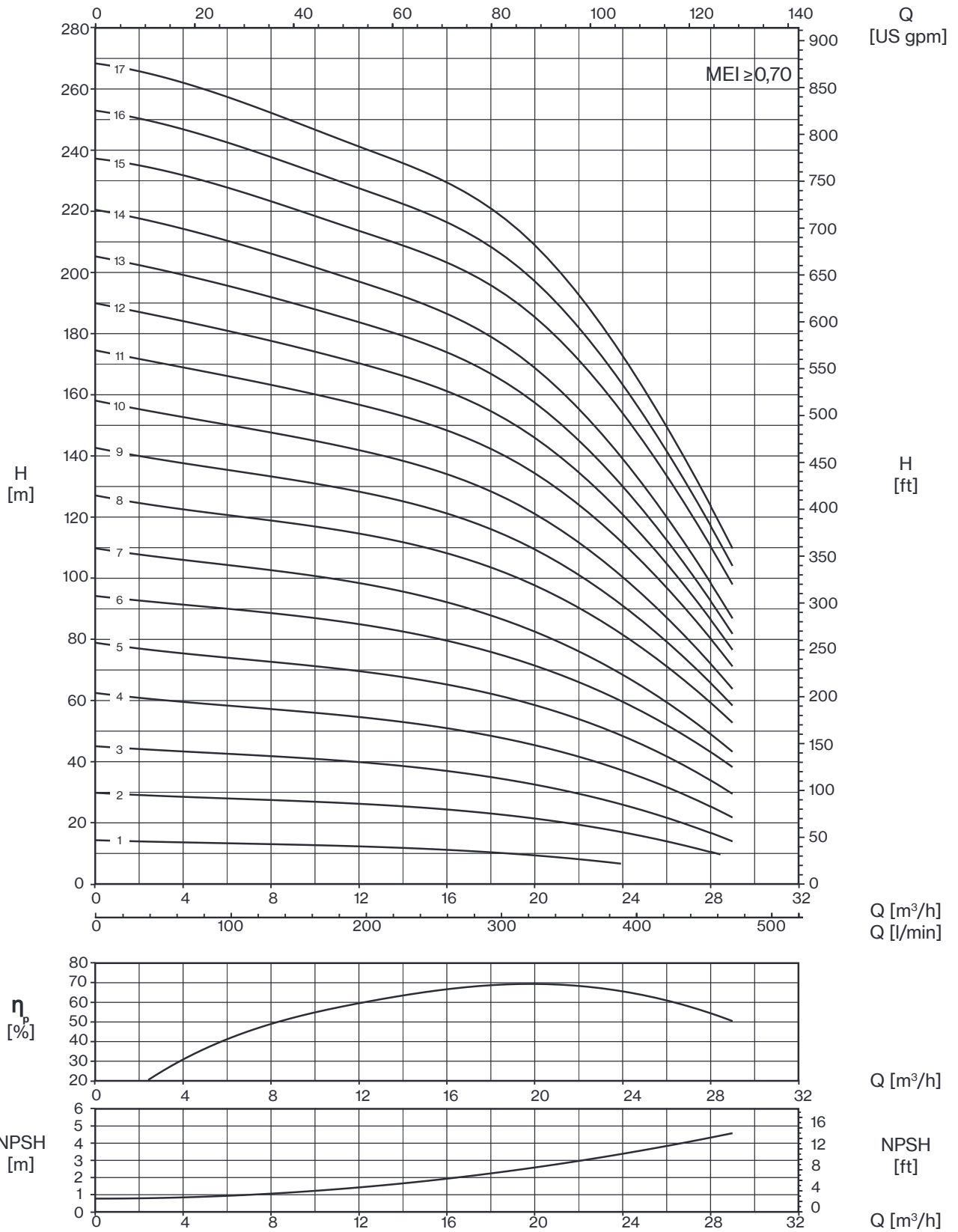

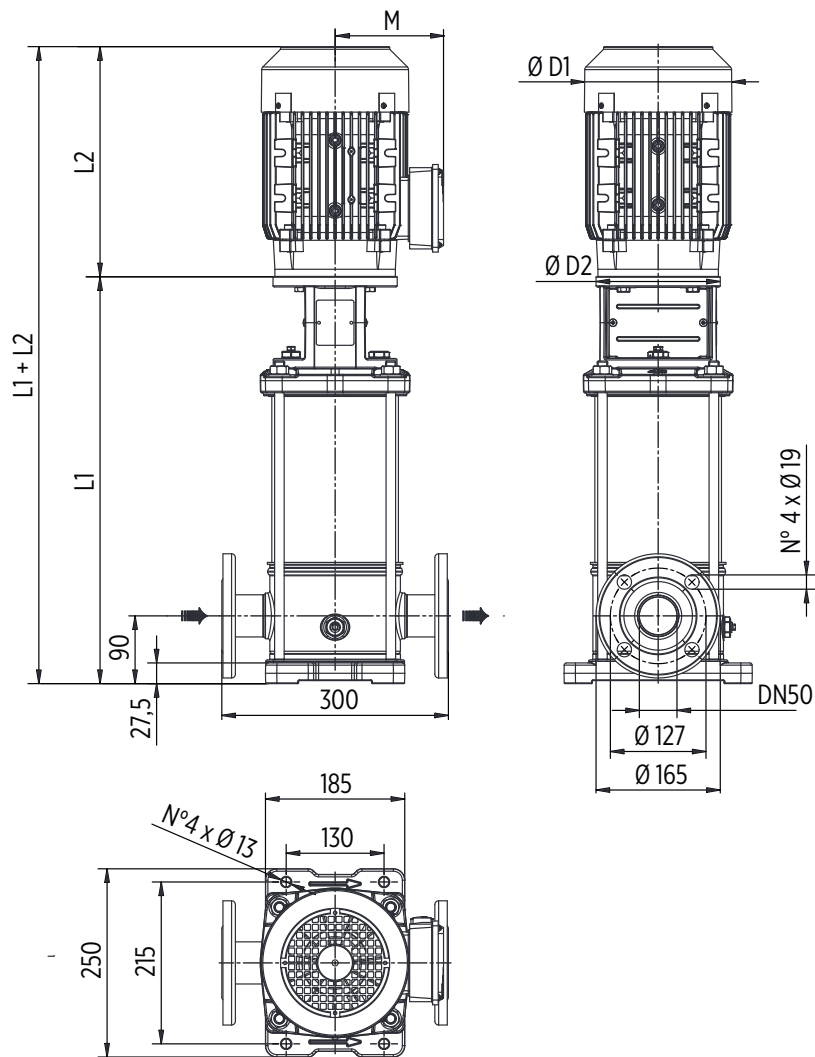

Round flanges on body type PN25/40: the pump is supplied without counterflanges (optional accessories, including bolts and joints)

TYPE	MOTOR		DIMENSIONS (mm)						Kg		
	kW	Dim	L1	L2	M	D1	D2	L1+L2	Pump	Motor	Electric Pump
U 18HX-100/1 T	0,75	80	396	243	130	157	170	639	19	17	36
U 18HX-200/2 T	1,5	90	396	280	145	177	170	676	20	23	43
U 18HX-300/3 T	2,2	90	444	308	145	177	170	752	21,5	26	47,5
U 18HX-400/4 T	3	100	492	333	157	205	170	825	22,5	35	57,5
U 18HX-550/5 T	4	112	540	350	177	220	170	890	24	43	67
U 18HX-750/6 T	5,5	132	800	400	197	256	300	1200	45,5	66	111,5
U 18HX-750/7 T	5,5	132	848	400	197	256	300	1248	46,5	66	112,5
U 18HX-1000/8 T	7,5	132	896	400	197	256	300	1296	48	73	121
U 18HX-1000/9 T	7,5	132	944	400	197	256	300	1344	49,5	73	122,5
U 18HX-1500/10 T	11	160	1012	503	255	315	350	1515	54	120	174
U 18HX-1500/11 T	11	160	1060	503	255	315	350	1563	55,5	120	175,5
U 18HX-1500/12 T	11	160	1108	503	255	315	350	1611	57	120	177
U 18HX-1500/13 T	11	160	1156	503	255	315	350	1659	58,5	120	178,5
U 18HX-1500/14 T	11	160	1204	503	255	315	350	1707	60	120	180
U 18HX-2000/15 T	15	160	1252	503	255	315	350	1755	61	132	193
U 18HX-2000/16 T	15	160	1300	503	255	315	350	1803	62,5	132	194,5
U 18HX-2000/17 T	15	160	1348	503	255	315	350	1851	64	132	196

22 HX

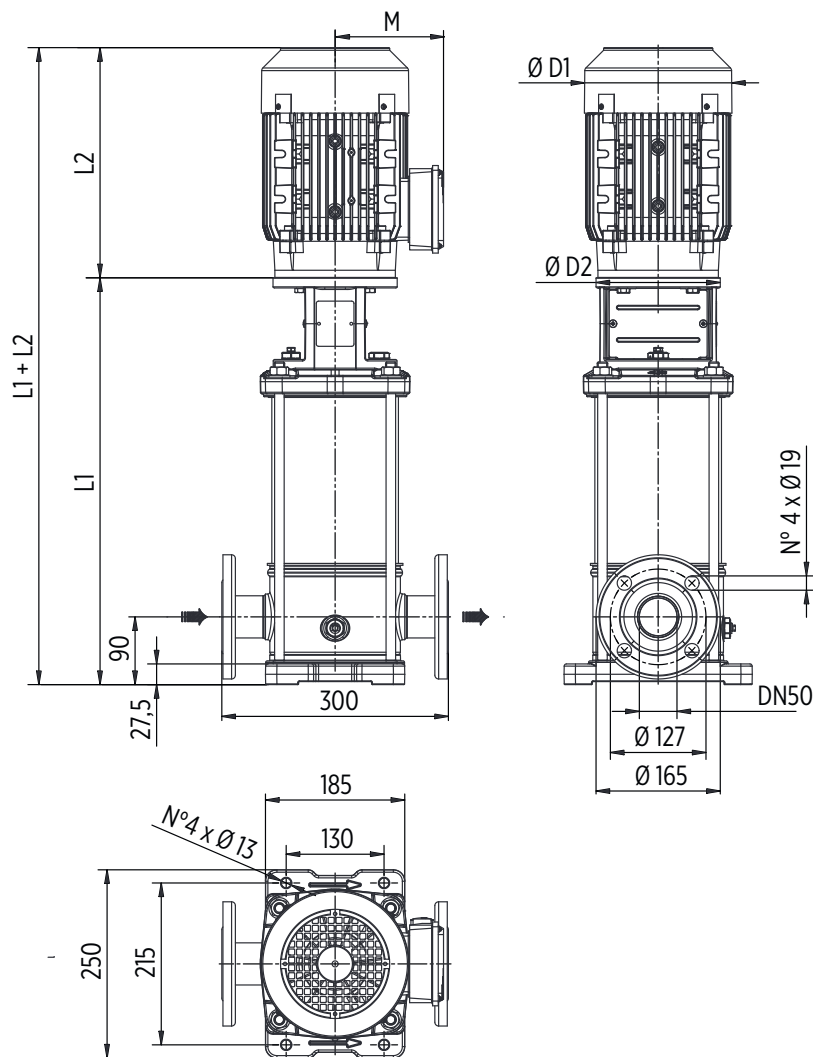



Round flanges on body type PN25/40: the pump is supplied without counterflanges (optional accessories, including bolts and joints)

TYPE	MOTOR		DIMENSIONS (mm)						Kg		
	kW	Dim	L1	L2	M	D1	D2	L1+L2	Pump	Motor	Electric Pump
U 22HX-200/1 T	1,1	80	396	243	130	157	170	639	19	18	37
U 22HX-300/2 T	2,2	90	396	308	145	177	170	704	20	26	46
U 22HX-400/3 T	3	100	444	333	157	205	170	777	21,5	35	56,5
U 22HX-550/4 T	4	112	492	350	177	220	170	842	22,5	43	65,5
U 22HX-750/5 T	5,5	132	752	400	197	256	300	1152	44	66	110
U 22HX-1000/6 T	7,5	132	800	400	197	256	300	1200	45,5	73	118,5
U 22HX-1000/7 T	7,5	132	848	400	197	256	300	1248	46,5	73	119,5
U 22HX-1500/8 T	11	160	916	503	255	315	350	1419	51,5	120	171,5
U 22HX-1500/9 T	11	160	964	503	255	315	350	1467	53	120	173
U 22HX-1500/10 T	11	160	1012	503	255	315	350	1515	54,5	120	174,5
U 22HX-2000/11 T	15	160	1060	503	255	315	350	1563	55,5	132	187,5
U 22HX-2000/12 T	15	160	1108	503	255	315	350	1611	57	132	189
U 22HX-2000/13 T	15	160	1156	503	255	315	350	1659	58,5	132	190,5
U 22HX-2000/14 T	15	160	1204	503	255	315	350	1707	60	132	192
U 22HX-2500/15 T	18,5	160	1252	598	252	315	350	1850	61,5	150	211,5
U 22HX-2500/16 T	18,5	160	1300	598	252	315	350	1898	62,5	150	212,5
U 22HX-2500/17 T	18,5	160	1348	598	252	315	350	1946	64	150	214



ULTRA HS-HX Serie-Mechanical seal and bearings

CARTRIDGE MECHANICAL SEAL	PUMP MODEL	SHAFT Ø		STANDARD MATERIAL	OPTIONAL		
	U18-100/1T, U18-200/2T, U18-300/3T, U18-400/4T, U18-550/5T, U18-750/6T, U18-750/7T, U18-1000/8T, U18-1000/9T, U18-1500/10T, U18-1500/11T, U18-1500/12T, U18-1500/13T, U18-1500/14T, U18-2000/15T, U18-2000/16T, U18-2000/17T, U22-150/1T, U22-300/2T, U22-400/3T, U22-550/4T, U22-750/5T, U22-1000/6T, U22-1000/7T, U22-1500/8T, U22-1500/9T, U22-1500/10T, U22-2000/11T, U22-2000/12T, U22-2000/13T	16mm	Rotating face Stationary face Elastomer	SiC Graphite EPDM	SiC Graphite FKM	SiC SiC EPDM	SiC SiC FKM
	U35-300/1T, U35-550/2-2RT, U35-550/2-1RT, U35-750/2T, U35-750/3-2RT, U35-1000/3-1RT, U35-1000/3T, U35-1000/4-2RT, U35-1500/4-1RT, U35-1500/4T, U35-1500/5-2RT, U35-1500/5-1RT, U35-2000/5T, U35-2000/6-2RT, U35-2000/6-1RT, U35-2000/6T, U35-2000/7-2RT, U35-2000/7-1RT, U35-2500/7T, U35-2500/8-2RT, U35-2500/8-1RT, U35-2500/8T, U35-3000/9-2RT, U35-3000/9-1RT, U35-3000/9T, U35-3000/10-2RT, U35-3000/10-1RT, U35-4000/10T, U35-4000/11-2RT, U35-4000/11-1RT, U35-4000/11T, U35-4000/12-2RT, U35-4000/12-1RT, U35-4000/12T, U35-4000/13-2RT, U35-4000/13-1RT, U35-4000/13T, U50-400/1-1RT, U50-550/1T, U50-750/2-2RT, U50-1000/2T, U50-1500/3-2RT, U50-1500/3T, U50-2000/4-2RT, U50-2000/4T, U50-2500/5-2RT, U50-2500/5T, U50-3000/6-2RT, U50-3000/6T, U50-4000/7-2RT, U50-4000/7T, U50-4000/8-2RT, U50-4000/8T, U50-5000/9-2RT, U50-5000/9T, U50-5000/10-2RT, U50-5000/10T, U50-6000/11-2RT, U50-6000/11T, U50-6000/12-2RT, U50-6000/12T, U50-6000/13-2RT, U75-550/1-1RT, U75-750/1T, U75-1000/2-2RT, U75-1500/2-1RT, U75-1500/2T, U75-2000/3-2RT, U75-2000/3-1RT, U75-2500/3T, U75-2500/4-2RT, U75-3000/4-1RT, U75-3000/4T, U75-4000/5-2RT, U75-4000/5-1RT, U75-4000/5T, U75-4000/6-2RT, U75-5000/6-1RT, U75-5000/6T, U75-5000/7-2RT, U75-5000/7-1RT, U75-6000/7T, U75-6000/8-2RT, U75-6000/8-1RT, U75-6000/8T, U90-750/1-1RT, U90-1000/1T, U90-1500/2-2RT, U90-2000/2T, U90-2500/3-2RT, U90-3000/3T, U90-4000/4-2RT, U90-4000/4T, U90-5000/5-2RT, U90-5000/5T, U90-6000/6-2RT, U90-6000/6T	22mm / Balanced seal	Rotating face Stationary face Elastomer	SiC Graphite EPDM	SiC Graphite FKM	SiC SiC EPDM	SiC SiC FKM

BEARINGS	PUMP MODEL	PUMP THRUST BEARING		MOTOR BEARING	
	U18-100/1T, U22-150/1T	-	-	6204-ZZ C3	6204-ZZ C3
	U18-200/2T, U18-300/3T, U22-300/2T, U35-300/1T	-	-	6205-ZZ C3	6205-ZZ C3
	U18-400/4T, U18-550/5T, U22-400/3T, U22-550/4T, U35-550/2-2RT, U35-550/2-1RT, U50-400/1-1RT, U50-550/1T, U75-550/1-1RT	-	-	6206-ZZ C3	6206-ZZ C3
	U18-750/6T, U18-750/7T, U18-1000/8T, U18-1000/9T, U22-750/5T, U22-1000/6T, U22-1000/15T, U35-750/2T, U35-750/3-2RT, U35-1000/3-1RT, U35-1000/3T, U35-1000/4-2RT, U50-750/2-2RT, U50-1000/2T, U75-750/1T, U75-1000/2-2RT, U90-750/1-1RT, U90-1000/1T	6212 ZZ	-	6208-ZZ C3	6208-ZZ C3
	U18-1500/10T, U18-1500/11T, U18-1500/12T, U18-1500/13T, U18-1500/14T, U18-2000/15T, U18-2000/16T, U18-2000/17T, U22-1500/8T, U22-1500/9T, U22-1500/10T, U22-2000/11T, U22-2000/12T, U22-2000/13T, U22-2000/14T, U22-2500/15T, U22-2500/16T, U22-2500/17T, U35-1500/4-1RT, U35-1500/4T, U35-1500/5-2RT, U35-1500/5-1RT, U50-1500/3-2RT, U50-1500/3T, U75-1500/2-1RT, U75-1500/2T, U90-1500/2-2RT	6212 ZZ	7212 BEP	6309-ZZ C3	6309-ZZ C3
	U35-2000/5T, U35-2000/6-2RT, U35-2000/6-1RT, U35-2000/6T, U35-2000/7-2RT, U35-2000/7-1RT, U35-2500/7T, U35-2500/8-2RT, U35-2500/8-1RT, U35-2500/8T, U50-2000/4-2RT, U50-2000/4T, U50-2500/5-2RT, U50-2500/5T, U75-2000/3-2RT, U75-2000/3-1RT, U75-2500/3T, U75-2500/4-2RT, U90-2000/2T, U90-2500/3-2RT	6212 ZZ	7212 BEP	6311-ZZ C3	6311-ZZ C3
	U35-3000/9-2RT, U35-3000/9-1RT, U35-3000/9T, U35-3000/10-2RT, U35-3000/10-1RT, U50-3000/6-2RT, U50-3000/6T, U75-3000/4-1RT, U75-3000/4T, U90-3000/3T	6214 ZZ	7214 BEP	6312-ZZ C3	6312-ZZ C3
	U35-4000/10T, U35-4000/11-2RT, U35-4000/11-1RT, U35-4000/11T, U35-4000/12-2RT, U35-4000/12-1RT, U35-4000/12T, U35-4000/13-2RT, U35-4000/13-1RT, U35-4000/13T, U50-4000/7-2RT, U50-4000/7-1RT, U50-4000/7T, U50-4000/8-2RT, U50-4000/8T, U50-5000/9-2RT, U50-5000/9T, U50-5000/10-2RT, U50-5000/10T, U75-4000/5-2RT, U75-4000/5-1RT, U75-4000/5T, U75-4000/6-2RT, U75-5000/6-1RT, U75-5000/6T, U75-5000/7-2RT, U75-5000/7-1RT, U90-4000/4-2RT, U90-4000/4T, U90-5000/5-2RT, U90-5000/5T	6214 ZZ	7214 BEP	6313-ZZ C3	6313-ZZ C3
	U50-6000/11-2RT, U50-6000/11T, U50-6000/12-2RT, U50-6000/12T, U50-6000/13-2RT, U75-6000/7T, U75-6000/8-2RT, U75-6000/8-1RT, U75-6000/8T, U90-6000/6-2RT, U90-6000/6T				



ULTRA+VSD

Vertical booster pump with variable speed



DESCRIPTION

Horizontal pump of ULTRA series provided with variable speed drive EPIC or IPFC. This booster pump assure the desired pressure regardless changes on flow demand making it suitable for low or missing pressure in residential systems and industrial applications. It is required the installation of a membrane tank downstream the system.

FEATURES

- EPIC or IPFC variable speed drive
- Vertical pump of ULTRA series
- Pressure sensor wired to the vsd
- Cable with plug for EPIC vsd only

FUNCTIONING

If the pressure in the network drops the pump will starts and gradually speeds up to provide with the set pressure. When the water demand decreases, the pressure will rise causing the pump speed to slow down and eventually to stop the pump if demand ceases. The pump will remain on standby waiting to start at the next water demand.

SELECTION

The table below shows the vertical ULTRA pump models available for the assembly with EPIC or IPFC. Consult the catalog at the ULTRA series for pump specifics and characteristic curves.



PUMP								VSD		
TYPE	MODEL	Version						TYPE	Power system	
		V	SV	L	SL/SLX	LG	SLG/SLGX		in	out
U 3	100/5T	■	■	■	■	-	-	EPIC	1-230	3-230
		■	■	■	■	-	-	IPFC109	1-230	3-230
		■	■	■	■	-	-	IPFC306	3-400	3-400
	120/6T	■	■	■	■	-	-	EPIC	1-230	3-230
		■	■	■	■	-	-	IPFC109	1-230	3-230
		■	■	■	■	-	-	IPFC306	3-400	3-400
	150/7T	■	■	■	■	-	-	EPIC	1-230	3-230
		■	■	■	■	-	-	IPFC109	1-230	3-230
		■	■	■	■	-	-	IPFC306	3-400	3-400
	180/8T	■	■	■	■	-	-	EPIC	1-230	3-230
		■	■	■	■	-	-	IPFC109	1-230	3-230
		■	■	■	■	-	-	IPFC306	3-400	3-400
	200/9T	■	■	■	■	-	-	EPIC	1-230	3-230
		■	■	■	■	-	-	IPFC109	1-230	3-230
■		■	■	■	-	-	IPFC306	3-400	3-400	
250/10T	■	■	■	■	-	-	EPIC	1-230	3-230	
	■	■	■	■	-	-	IPFC114	1-230	3-230	
	■	■	■	■	-	-	IPFC306	3-400	3-400	
280/11T	-	■	-	■	-	-	EPIC	1-230	3-230	
	■	■	■	■	-	-	IPFC114	1-230	3-230	
	■	■	■	■	-	-	IPFC306	3-400	3-400	
300/12T	■	■	■	■	-	-	IPFC114	1-230	3-230	
	■	■	■	■	-	-	IPFC306	3-400	3-400	
	-	-	-	-	-	■	IPFC114	1-230	3-230	
350/14T	-	-	-	-	-	■	IPFC306	3-400	3-400	
	-	-	-	-	-	■	IPFC114	1-230	3-230	
	-	-	-	-	-	■	IPFC309	3-400	3-400	
380/16T	-	-	-	-	-	■	IPFC309	3-400	3-400	
	-	-	-	-	-	■	IPFC309	3-400	3-400	
	-	-	-	-	-	■	IPFC309	3-400	3-400	
U 5	120/4T	■	■	■	■	-	-	EPIC	1-230	3-230
		■	■	■	■	-	-	IPFC109	1-230	3-230
		■	■	■	■	-	-	IPFC306	3-400	3-400
	150/5T	■	■	■	■	-	-	EPIC	1-230	3-230
		■	■	■	■	-	-	IPFC109	1-230	3-230
		■	■	■	■	-	-	IPFC306	3-400	3-400
	180/6T	■	■	■	■	-	-	EPIC	1-230	3-230
		■	■	■	■	-	-	IPFC109	1-230	3-230
		■	■	■	■	-	-	IPFC306	3-400	3-400
	200/7T	■	■	■	■	-	-	EPIC	1-230	3-230
		■	■	■	■	-	-	IPFC109	1-230	3-230
		■	■	■	■	-	-	IPFC306	3-400	3-400
	250/8T	■	■	■	■	-	-	EPIC	1-230	3-230
		■	■	■	■	-	-	IPFC114	1-230	3-230
■		■	■	■	-	-	IPFC306	3-400	3-400	
280/9T	■	■	■	■	-	-	IPFC114	1-230	3-230	
	■	■	■	■	-	-	IPFC306	3-400	3-400	
	■	■	■	■	-	-	IPFC114	1-230	3-230	
300/10T	■	■	■	■	-	-	IPFC306	3-400	3-400	
	■	■	■	■	-	-	IPFC114	1-230	3-230	
	■	■	■	■	-	-	IPFC306	3-400	3-400	
350/11T	■	■	■	■	-	-	IPFC114	1-230	3-230	
	■	■	■	■	-	-	IPFC306	3-400	3-400	
	■	■	■	■	-	-	IPFC309	3-400	3-400	
380/12T	■	■	■	■	-	-	IPFC309	3-400	3-400	
	-	-	-	-	-	■	IPFC309	3-400	3-400	
	-	-	-	-	-	■	IPFC309	3-400	3-400	
400/14T	-	-	-	-	-	■	IPFC309	3-400	3-400	
	-	-	-	-	-	■	IPFC309	3-400	3-400	
	-	-	-	-	-	■	IPFC309	3-400	3-400	
450/16T	-	-	-	-	-	■	IPFC309	3-400	3-400	
	-	-	-	-	-	■	IPFC309	3-400	3-400	
	-	-	-	-	-	■	IPFC309	3-400	3-400	
550/18T	-	-	-	-	-	■	IPFC309	3-400	3-400	
	-	-	-	-	-	■	IPFC309	3-400	3-400	
	-	-	-	-	-	■	IPFC309	3-400	3-400	
600/20T	-	-	-	-	-	■	IPFC311	3-400	3-400	
	-	-	-	-	-	■	IPFC311	3-400	3-400	
	-	-	-	-	-	■	IPFC311	3-400	3-400	



ULTRA+VSD

		PUMP						VSD		
TYPE	MODEL	Version						TYPE	Power system	
		V	SV	L	SL/SLX	LG	SLG/SLGX		in	out
U 7	180/4T	■	■	■	■	-	-	EPIC	1-230	3-230
		■	■	■	■	-	-	IPFC109	1-230	3-230
		■	■	■	■	-	-	IPFC306	3-400	3-400
	250/5T	■	■	■	■	-	-	IPFC114	1-230	3-230
		■	■	■	■	-	-	IPFC306	3-400	3-400
	300/6T	■	■	■	■	-	-	IPFC114	1-230	3-230
		■	■	■	■	-	-	IPFC306	3-400	3-400
	350/7T	■	■	■	■	-	-	IPFC114	1-230	3-230
		■	■	■	■	-	-	IPFC306	3-400	3-400
	400/8T	■	■	■	■	-	-	IPFC309	3-400	3-400
	450/9T	■	■	■	■	-	-	IPFC309	3-400	3-400
	550/10T	■	■	■	■	-	-	IPFC311	3-400	3-400
750/12T	-	-	-	-	-	■	IPFC311	3-400	3-400	
800/14T	-	-	-	-	-	■	IPFC314	3-400	3-400	
900/16T	-	-	-	-	-	■	IPFC314	3-400	3-400	
950/18T	-	-	-	-	-	■	IPFC318	3-400	3-400	
1000/20T	-	-	-	-	-	■	IPFC318	3-400	3-400	
U 9	200/4T	■	■	■	■	-	-	EPIC	1-230	3-230
		■	■	■	■	-	-	IPFC109	1-230	3-230
		■	■	■	■	-	-	IPFC306	3-400	3-400
	250/5T	■	■	■	■	-	-	EPIC	1-230	3-230
		■	■	■	■	-	-	IPFC114	1-230	3-230
	300/6T	■	■	■	■	-	-	IPFC306	3-400	3-400
		■	■	■	■	-	-	IPFC114	1-230	3-230
	400/7T	■	-	■	-	-	-	IPFC306	3-400	3-400
		■	-	■	-	-	-	IPFC309	3-400	3-400
	450/8T	■	■	■	■	-	-	IPFC309	3-400	3-400
	500/9T	■	■	■	■	-	-	IPFC309	3-400	3-400
	550/10T	■	■	■	■	-	-	IPFC311	3-400	3-400
	750/12T	-	-	-	-	-	■	IPFC311	3-400	3-400
	800/14T	-	-	-	-	-	■	IPFC314	3-400	3-400
900/16T	-	-	-	-	-	■	IPFC314	3-400	3-400	
950/18T	-	-	-	-	-	■	IPFC318	3-400	3-400	
1000/20T	-	-	-	-	-	■	IPFC318	3-400	3-400	



PUMP									VSD		
TYPE	MODEL	Version							TYPE	Power system	
		V	SV	L	SL/SLX	LG	HS	HX		in	out
U 18	100/1T	-	-	-	-	-	-	■	IPFC109	1-230	3-230
		-	-	-	-	-	-	■	IPFC306	3-400	3-400
	200/2T	-	-	-	-	-	-	■	IPFC109	1-230	3-230
		-	-	-	-	-	-	■	IPFC306	3-400	3-400
	250/3T	■	■	■	■	-	-	-	EPIC	1-230	3-230
		■	■	■	■	-	-	-	IPFC114	1-230	3-230
		■	■	■	■	-	-	-	IPFC306	3-400	3-400
	300/3T	-	-	-	-	-	-	■	IPFC114	1-230	3-230
		-	-	-	-	-	-	■	IPFC306	3-400	3-400
	400/4T	■	■	■	■	-	-	■	IPFC114	1-230	3-230
		■	■	■	■	-	-	■	IPFC306	3-400	3-400
	450/5T	■	■	■	■	-	-	-	IPFC309	3-400	3-400
	550/5T	-	-	-	-	-	-	■	IPFC309	3-400	3-400
	550/6T	■	■	■	■	-	-	-	IPFC311	3-400	3-400
	750/6T	-	-	-	-	-	-	■	IPFC311	3-400	3-400
	750/7T	-	-	-	-	-	-	■	IPFC311	3-400	3-400
	750/8T	■	■	■	■	-	-	-	IPFC314	3-400	3-400
	900/9T	■	■	■	■	-	-	-	IPFC318	3-400	3-400
	920/10T	-	-	-	-	■	-	-	IPFC318	3-400	3-400
	1000/8T	-	-	-	-	-	-	■	IPFC314	3-400	3-400
1000/9T	-	-	-	-	-	-	■	IPFC314	3-400	3-400	
1000/11T	-	-	-	-	■	-	-	IPFC318	3-400	3-400	
1500/10T	-	-	-	-	-	-	■	IPFC318	3-400	3-400	
1500/11T	-	-	-	-	-	-	■	IPFC318	3-400	3-400	
1500/12T	-	-	-	-	-	-	■	IPFC325	3-400	3-400	
1500/13T	-	-	-	-	-	-	■	IPFC325	3-400	3-400	
1500/14T	-	-	-	-	-	-	■	IPFC325	3-400	3-400	
2000/15T	-	-	-	-	-	-	■	IPFC325	3-400	3-400	
2000/16T	-	-	-	-	-	-	■	IPFC325	3-400	3-400	
2000/17T	-	-	-	-	-	-	■	IPFC330	3-400	3-400	
U 22	200/1T	-	-	-	-	-	-	■	IPFC109	1-230	3-230
		-	-	-	-	-	-	■	IPFC306	3-400	3-400
	300/2T	-	-	-	-	-	-	■	IPFC114	1-230	3-230
		-	-	-	-	-	-	■	IPFC306	3-400	3-400
	400/3T	-	-	-	-	-	-	■	IPFC309	3-400	3-400
	550/4T	-	-	-	-	-	-	■	IPFC311	3-400	3-400
	750/5T	-	-	-	-	-	-	■	IPFC311	3-400	3-400
	1000/6T	-	-	-	-	-	-	■	IPFC314	3-400	3-400
	1000/7T	-	-	-	-	-	-	■	IPFC318	3-400	3-400
	1500/8T	-	-	-	-	-	-	■	IPFC318	3-400	3-400
	1500/9T	-	-	-	-	-	-	■	IPFC325	3-400	3-400
	1500/10T	-	-	-	-	-	-	■	IPFC325	3-400	3-400
	2000/11T	-	-	-	-	-	-	■	IPFC325	3-400	3-400
	2000/12T	-	-	-	-	-	-	■	IPFC325	3-400	3-400
2000/13T	-	-	-	-	-	-	■	IPFC330	3-400	3-400	
2000/14T	-	-	-	-	-	-	■	IPFC330	3-400	3-400	



ULTRA+VSD

		PUMP							VSD		
TYPE	MODEL	Version							TYPE	Power system	
		V	SV	L	SL/SLX	LG	HS	HX		in	out
U 35	300/1T	-	-	-	-	-	■	■	IPFC114	1-230	3-230
		-	-	-	-	-	■	■	IPFC306	3-400	3-400
	550/2-2RT	-	-	-	-	-	■	■	IPFC309	3-400	3-400
	550/2-1RT	-	-	-	-	-	■	■	IPFC309	3-400	3-400
	750/2T	-	-	-	-	-	■	■	IPFC311	3-400	3-400
	750/3-2RT	-	-	-	-	-	■	■	IPFC311	3-400	3-400
	1000/3-1RT	-	-	-	-	-	■	■	IPFC314	3-400	3-400
	1000/3T	-	-	-	-	-	■	■	IPFC314	3-400	3-400
	1000/4-2RT	-	-	-	-	-	■	■	IPFC318	3-400	3-400
	1500/4-1RT	-	-	-	-	-	■	■	IPFC318	3-400	3-400
	1500/4T	-	-	-	-	-	■	■	IPFC325	3-400	3-400
	1500/5-2RT	-	-	-	-	-	■	■	IPFC325	3-400	3-400
	1500/5-1RT	-	-	-	-	-	■	■	IPFC325	3-400	3-400
	2000/5T	-	-	-	-	-	■	■	IPFC325	3-400	3-400
	2000/6-2RT	-	-	-	-	-	■	■	IPFC325	3-400	3-400
	2000/6-1RT	-	-	-	-	-	■	■	IPFC330	3-400	3-400
2000/6T	-	-	-	-	-	■	■	IPFC330	3-400	3-400	
2000/7-2RT	-	-	-	-	-	■	■	IPFC330	3-400	3-400	
2000/7-1RT	-	-	-	-	-	■	■	IPFC330	3-400	3-400	
U 50	400/1-1RT	-	-	-	-	-	■	■	IPFC114	1-230	3-230
		-	-	-	-	-	■	■	IPFC306	3-400	3-400
	550/1T	-	-	-	-	-	■	■	IPFC309	3-400	3-400
	750/2-2RT	-	-	-	-	-	■	■	IPFC311	3-400	3-400
	1000/2T	-	-	-	-	-	■	■	IPFC318	3-400	3-400
	1500/3-2RT	-	-	-	-	-	■	■	IPFC325	3-400	3-400
	1500/3T	-	-	-	-	-	■	■	IPFC318	3-400	3-400
	2000/4-2RT	-	-	-	-	-	■	■	IPFC325	3-400	3-400
2000/4T	-	-	-	-	-	■	■	IPFC330	3-400	3-400	
U 75	550/1-1RT	-	-	-	-	-	■	■	IPFC309	3-400	3-400
	750/1T	-	-	-	-	-	■	■	IPFC311	3-400	3-400
	1000/2-2RT	-	-	-	-	-	■	■	IPFC318	3-400	3-400
	1500/2-1RT	-	-	-	-	-	■	■	IPFC318	3-400	3-400
	1500/2T	-	-	-	-	-	■	■	IPFC325	3-400	3-400
	2000/3-2RT	-	-	-	-	-	■	■	IPFC325	3-400	3-400
	2000/3-1RT	-	-	-	-	-	■	■	IPFC330	3-400	3-400
U 90	750/1-1RT	-	-	-	-	-	■	■	IPFC311	3-400	3-400
	1000/1T	-	-	-	-	-	■	■	IPFC318	3-400	3-400
	1500/2-2RT	-	-	-	-	-	■	■	IPFC325	3-400	3-400
	2000/2T	-	-	-	-	-	■	■	IPFC330	3-400	3-400

