

Multi-stage centrifugal pumps, horizontal and self-priming, particularly suitable for constructing small and medium sized pressurisation systems; able to suck liquids mixed with air or gas.

Construction features

Pump body	stainless steel AISI 304
Motor bracket	aluminum
Impeller	Noryl®
Mechanical seal	ceramic-graphite-NBR
Pump shaft	stainless steel AISI 416
Liquid temperature	0 - 50 °C
Operating pressure	max 8 bar

Motor

	3~ 230/400V-50Hz
2 poles induction motor	1~ 230V-50Hz (with thermal protection)
Insulation class	F
Protection degree	IPX4

TYPE	LOTS			
	TRUCK		CONTAINER	
	PALLET (cm)	N° pumps	PALLET (cm)	N° pumps
JXM	85×110×170	60	85×110×190	80

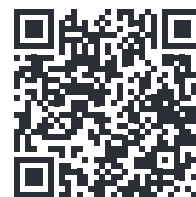

JXM

Q [imp g.p.m]

Q [US g.p.m.]

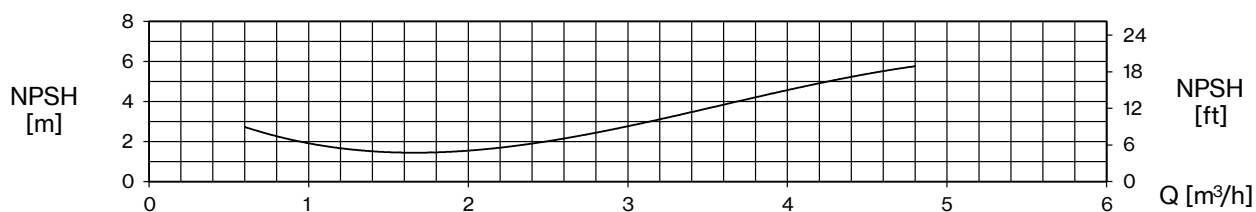
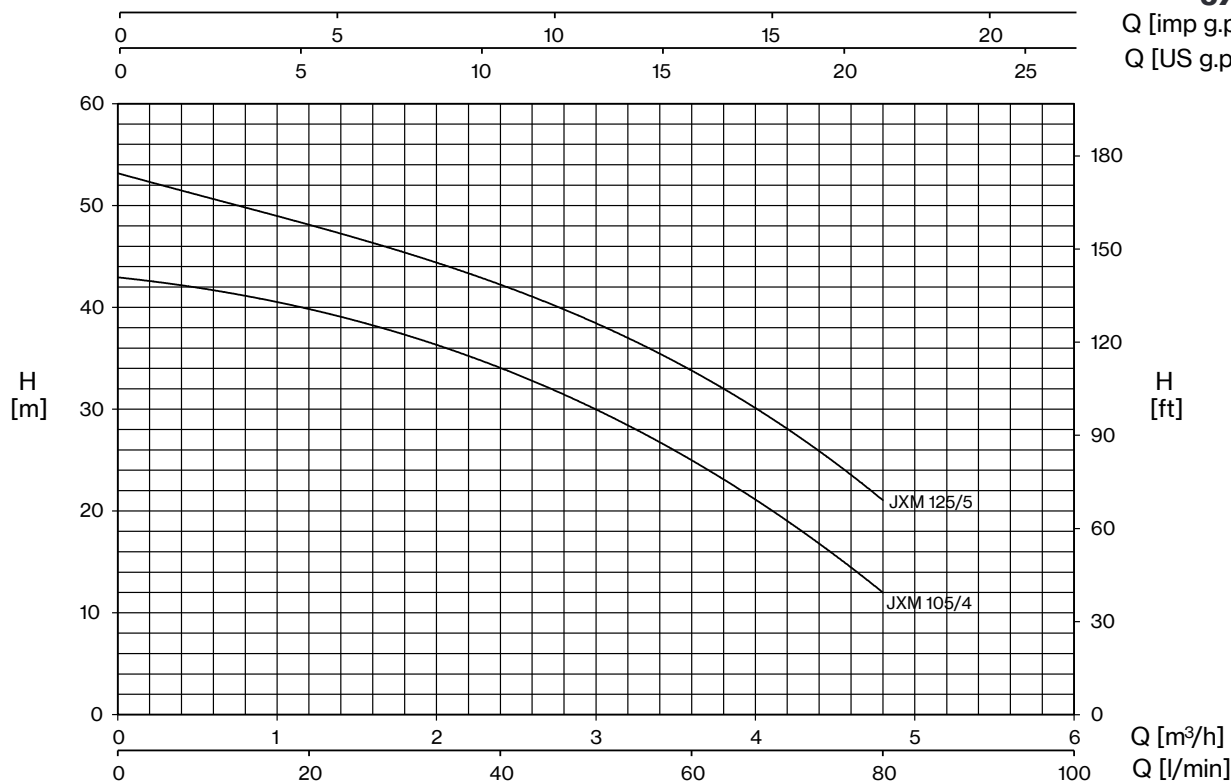

TYPE		P2		P1 (kW)		AMPERE		Q (m³/h - l/min)					
1~	3~	HP	kW	1~	3~	1~ 1x230 V 50 Hz	3~ 3x400 V 50 Hz	0	0,6	1,2	2,4	3,6	4,8
								0	10	20	40	60	80
								H (m)					
JXM 105/4	JXM 105/4 T	1	0,74	1,07	1,1	5,0	1,9	43,0	41,5	40,0	34,0	25,0	12,0
JXM 125/5	JXM 125/5 T	1,2	0,88	1,27	1,33	6,1	2,3	53,0	51,0	48,0	42,0	34,0	21,0

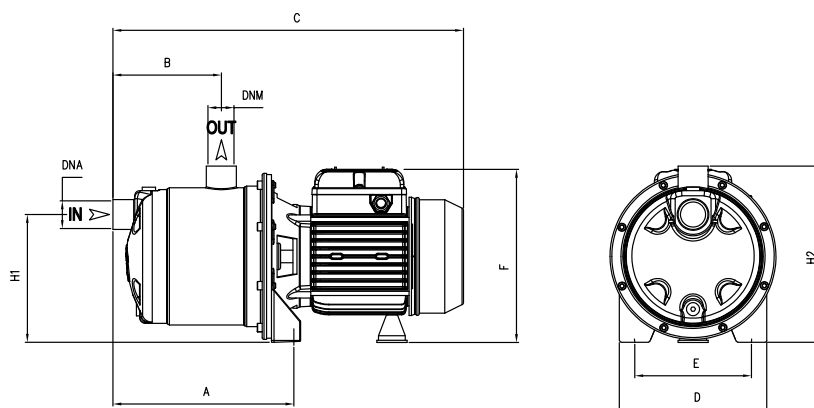

TYPE	DIMENSIONS (mm)													
	A	B	C	D	E	F	H1	H2	DNA	DNM	I	L	M	Kg
JXM 105/4	208	128	410	175	140	215	153	210			430	210	235	11
JXM 125/5	208	128	410	175	140	215	153	210	1" G	1" G	430	210	235	11,5

JXM (Garden version)

Portable electropumps complete with handle, cable with plug and switch.
The performances depend on adopted pump type.



JXM



JXM BOX

TYPE	P2		P1 (kW)	Pipe		Performance	
	HP	kW		Suction ("G)	Delivery ("G)	Q (l/min)	H (m)
JXM 100/4/G	1	0,74	1,07	1	1	10-80	41,5-12
JXM 120/5/G	1,2	0,88	1,27	1	1	10-80	51-21

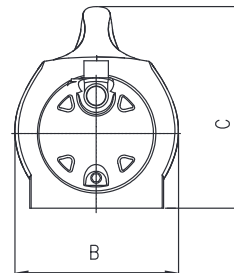
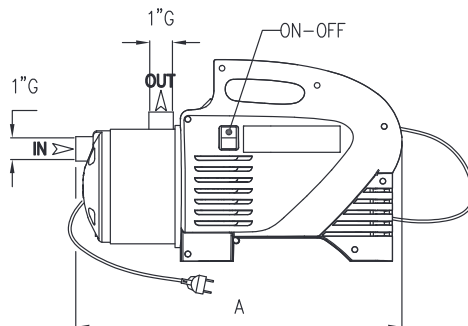
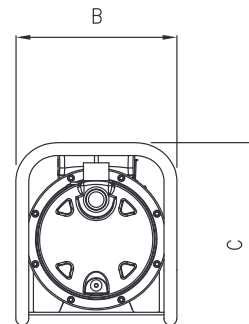
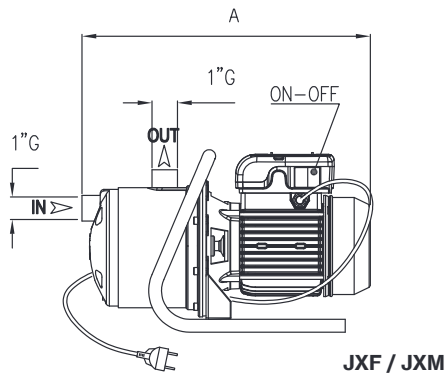

TYPE	DIMENSIONS (mm)		
	A	B	C
JXM 100/4/G	410	175	285
JXM 120/5/G	410	175	285
JXM 100/4 BOX	429	209	287