

MON/A

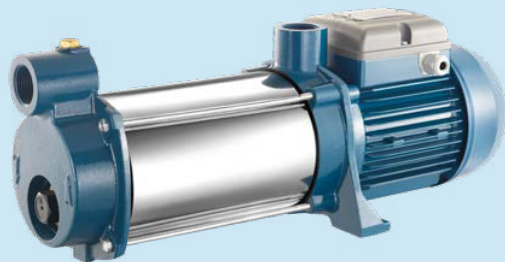

Self-priming



Multi-stage centrifugal pump, horizontal and self-priming, particularly suitable for constructing small and medium sized pressurisation systems; able to suck liquids mixed with air or gas.

Construction features

Pump body	cast iron
Motor bracket	cast iron
Impeller	Noryl®
Mechanical seal	ceramic-graphite-NBR
Motor shaft	stainless steel AISI 416
Liquid temperature	0 - 50 °C
Operating pressure	max 11 bar

Motor

	3~ 230/400V-50Hz
2 poles induction motor	1~ 230V-50Hz (with thermal protector)
Insulation class	F
Protection degree	IPX4

TYPE	LOTS			
	TRUCK		CONTAINER	
	PALLET (cm)	N° pumps	PALLET (cm)	N° pumps
MON/A	80×120×150	48	80×120×190	64

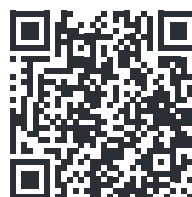

MON/A

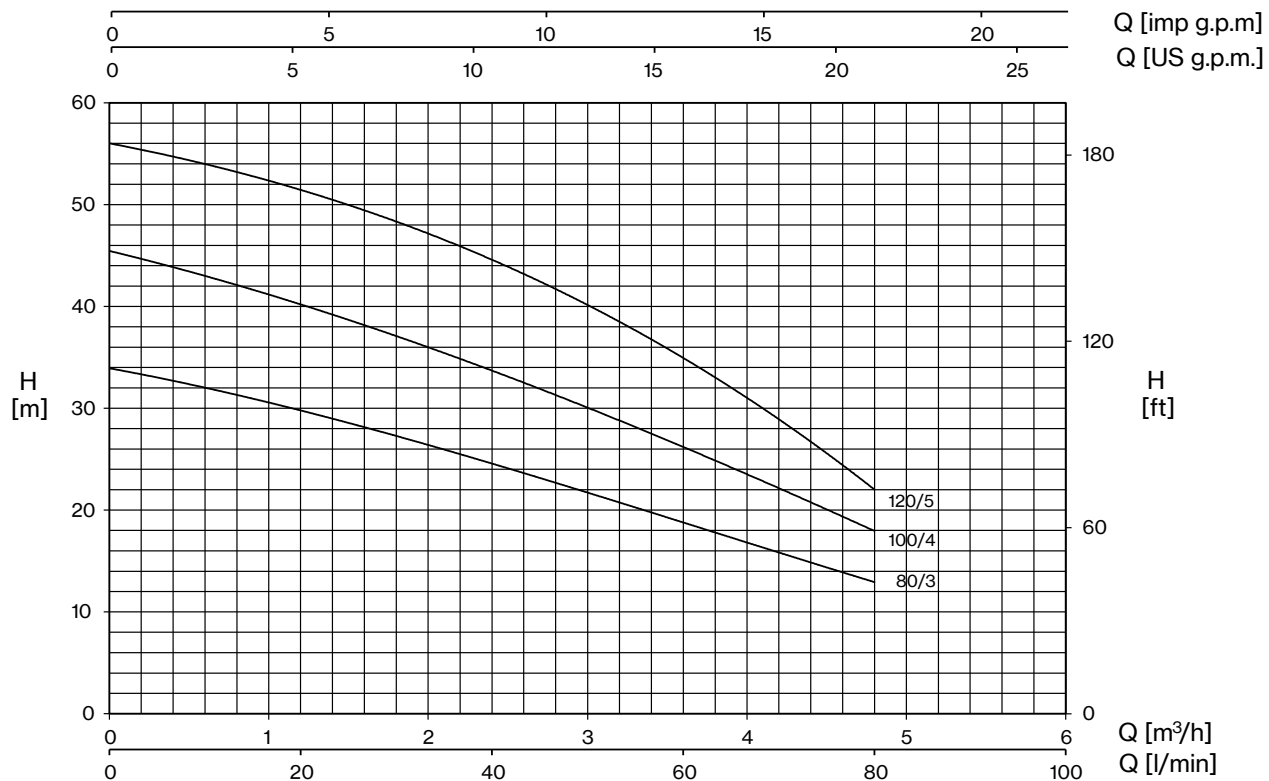

TYPE		P2		P1 (kW)		AMPERE		Q (m³/h - l/min)				
1~	3~					1~	3~	0	1,2	2,4	3,6	4,8
		HP	kW	1~	3~	1x230 V 50 Hz	3x400 V 50 Hz	0	20	40	60	80
		H (m)										
MON 80/3 A	MON 80/3 A T	0,8	0,59	0,83	0,88	3,8	1,6	34,0	29,5	25,0	18,5	13,0
MON 100/4 A	MON 100/4 A T	1	0,74	1,07	1,1	5,0	1,9	45,5	40,0	34,0	26,0	18,0
MON 120/5 A	MON 120/5 A T	1,2	0,88	1,27	1,33	6,1	2,3	56,0	51,5	44,5	35,0	22,0

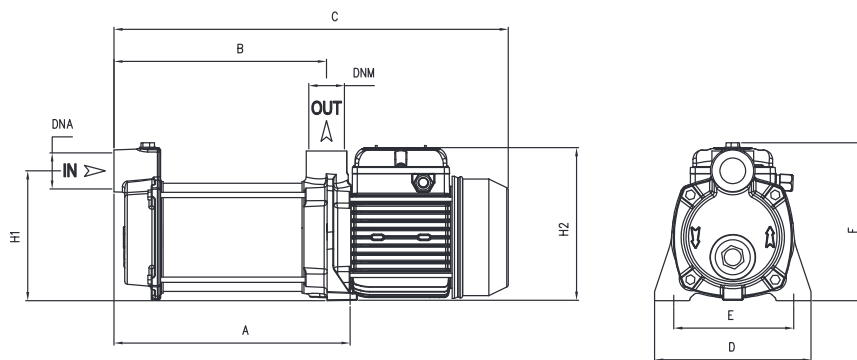

TYPE	DIMENSIONS (mm)													Kg
	A	B	C	D	E	F	H1	H2	DNA	DNM	I	L	M	
MON 80/3 A	245	224	425	180	140	185	150	175			440	200	215	14
MON 100/4 A	270	240	450	180	140	185	150	175	1" G	1" G	500	200	215	15,5
MON 120/5 A	295	264	475	180	140	185	150	175			500	200	215	16