



Single channel centrifugal drainage pump. Specifically designed for heavy duty applications it guarantees high capacity at medium head; ideal for civil and industrial applications. Available in mobile or permanent version with coupling feet.

Construction features

Pump body	cast iron
 Impeller	cast iron
Mechanical seal	double seal with oil barrier: silicon carbide on pump side, ceramic-graphite on motor side
Motor shaft	stainless steel AISI 304
Free passage	50 mm
Max submergence	max 20 m
Liquid temperature	0 - 40 °C
Cable	H05 RN8F, 10 m
Bolts	A2 stainless steel
Foot support	galvanized iron
Gaskets	NBR rubber

Motor

3~ 230/400V-50Hz	$P \leq 4\text{kW}$
3~ 400/690V-50Hz	$P > 4\text{kW}$
2 Poles induction motor	1~ 230V-50Hz required run capacitor (35µF for 1,5HP model, 50µF for 2HP model)
Insulation class	F
Protection degree	IPX8

TYPE	LOTS			
	TRUCK		CONTAINER	
	PALLET (cm)	N° pumps	PALLET (cm)	N° pumps
DM 160-310	85×110×145	18	85×110×190	27
DMT 410-560	85×110×170	12	85×110×170	12
DMT 1000	100×120×190	12	100×120×190	12

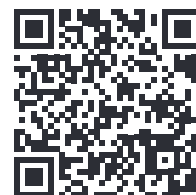
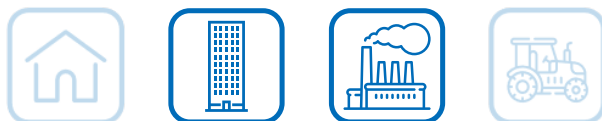

DM

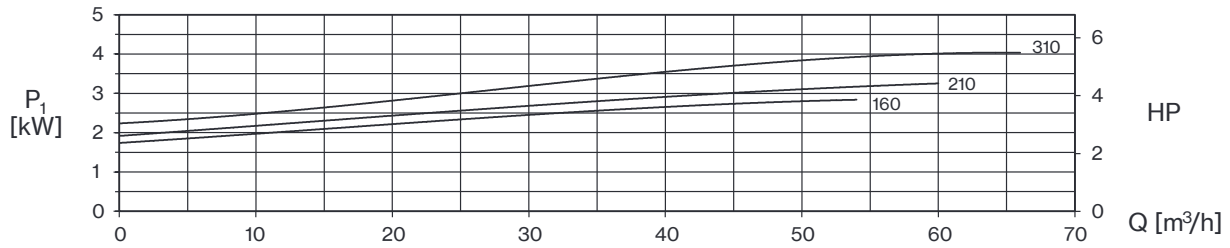
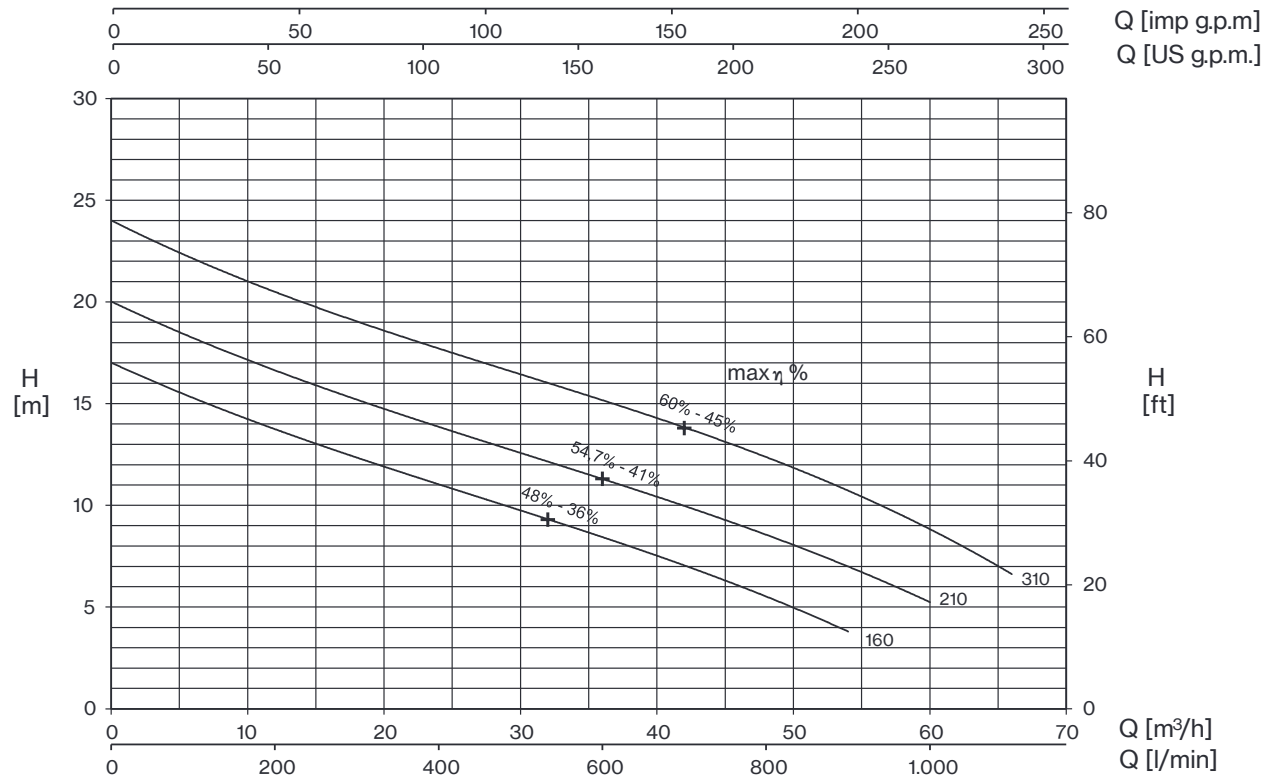

TYPE		AMPERE				
1~	3~	230 V 50 Hz	3x230 V 50 Hz (*)	3x400 V 50 Hz	230/400 V 50 Hz λ/Δ (*)	400/690 V 50 Hz λ/Δ
DM 160	DMT 160	12,5	7,6	4,4	-	-
DM 210	DMT 210	15	9,5	5,5	-	-
-	DMT 310	-	12	6,9	-	-

+ max η %

max hydraulic efficiency and respective total efficiency

(*) no standard execution

TYPE		P ₂		P ₁ (kW)		Q (m³/h - l/min)												
1~	3~	HP	kW	1~	3~	0	6	12	18	24	30	36	42	48	54	60	66	
						0	100	200	300	400	500	600	700	800	900	1000	1100	
						H (m)												
DM 160	DMT 160	1,5	1,1	2,8	2,6	17,0	15,3	13,8	12,3	11,0	9,8	8,4	7,1	5,5	3,8			
DM 210	DMT 210	2	1,5	3,3	3,1	19,9	18,4	16,7	15,2	13,8	12,4	11,3	10,1	8,6	7,0	5,2		
-	DMT 310	3	2,2	-	4,1	23,9	22,2	20,6	19,1	17,8	16,3	15,0	13,8	12,3	10,9	9,1	6,4	



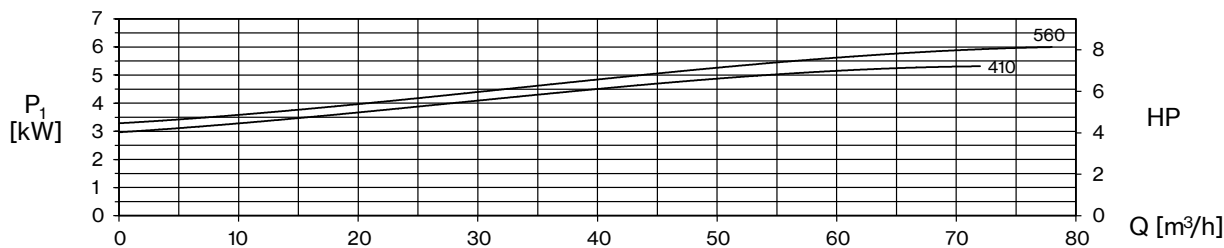
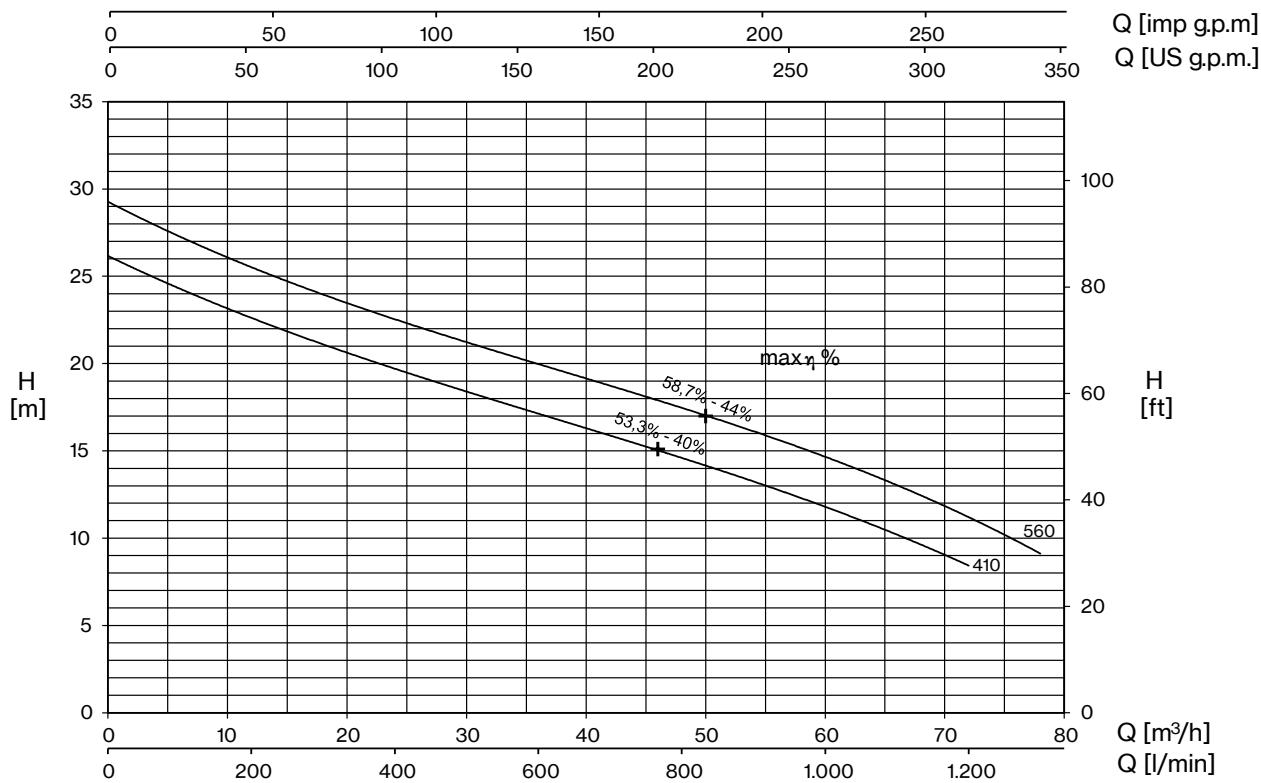

TYPE	AMPERE			
	3x230 V 50 Hz (*)	3x400 V 50 Hz	230/400 V 50 Hz λ / Δ (*)	400/690 V 50 Hz λ / Δ
DMT 410	15,4	8,9	-	-
DMT 560	17,6	10,2	-	-

+ max η %

max hydraulic efficiency and respective total efficiency

(*) no standard execution

TYPE	P ₂		P ₁ (kW)	Q (m³/h - l/min)									
				0	6	18	30	42	54	60	66	72	78
	HP	kW	3-	0	100	300	500	700	900	1000	1100	1200	1300
DMT 410	4	3	5,3	26	24,6	21,1	18,2	15,9	13,3	11,8	10,3	8,3	
DMT 560	5,5	4	6,0	29,1	27,5	24,1	21,1	18,6	16,1	14,7	13,1	11,4	8,9



DM

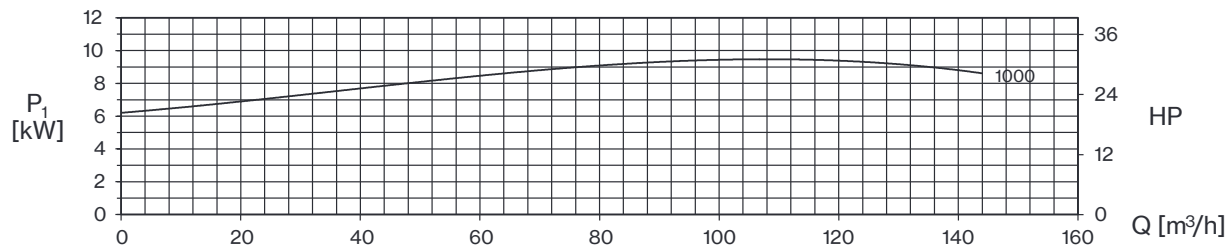
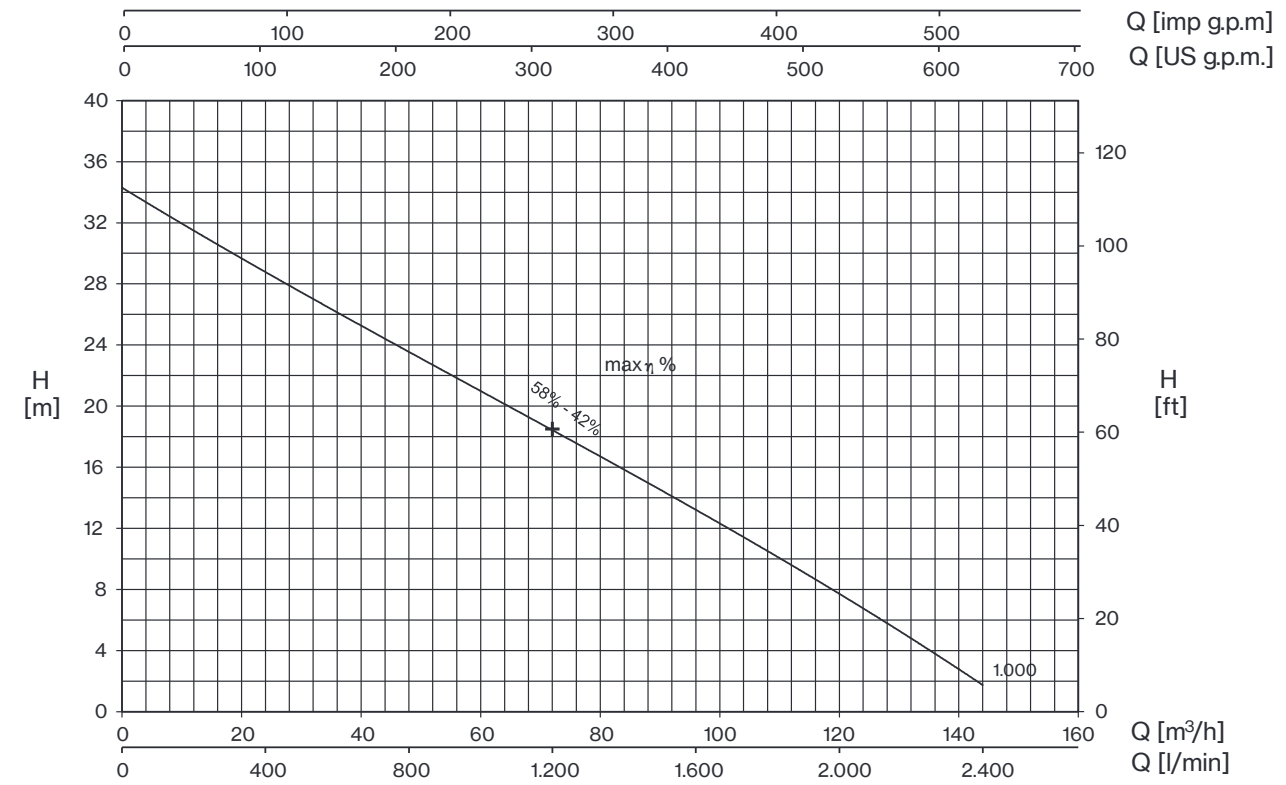

TYPE	AMPERE			
	3x230 V 50 Hz (*)	3x400 V 50 Hz	230/400 V 50 Hz λ / Δ (*)	400/690 V 50 Hz λ / Δ
DMT 1000	-	16,3	28,2	16,3

+ max η %

max hydraulic efficiency and respective total efficiency

(*) no standard execution

TYPE	P2		P1 (kW)	Q (m³/h - l/min)													
				0	12	24	36	48	60	72	84	96	108	120	132	144	
3~	HP	kW	3~	H (m)													
				0	200	400	600	800	1000	1200	1400	1600	1800	2000	2200	2400	
DMT 1000	10	7,5	9,6	34,9	30,9	28,3	26,1	23,7	21,3	18,7	16,1	13,2	10,2	7,4	4,6	2,1	



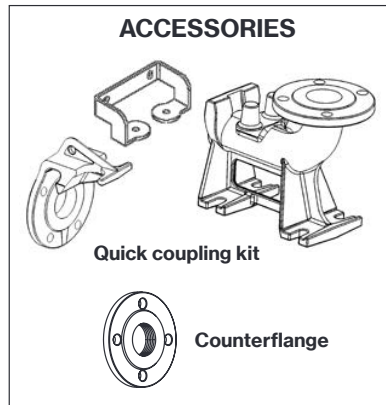
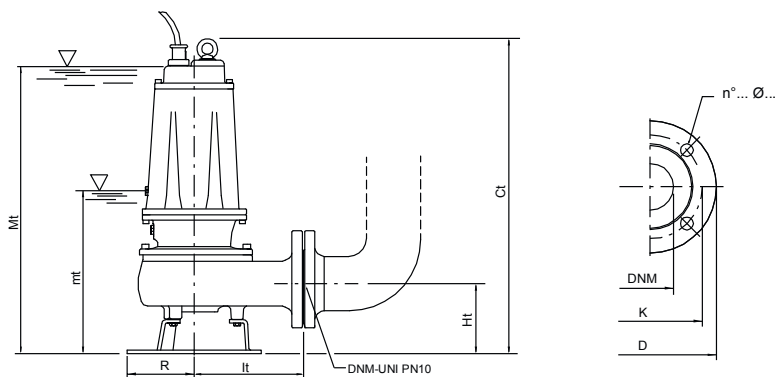

TYPE	DIMENSIONS (mm)							Kg
	Ct	Ht	R	It	mt	Mt	DNM	
DMT 160	551	123	117	191	243	513	65	40
DM 160-DMT 210	551	123	117	191	243	513	65	41,5
DM 210-DMT 310	551	123	117	191	243	513	65	42,5
DMT 410	645	148	160	210	285	600	80	68
DMT 560	645	148	160	210	285	600	80	71,5
DMT 1000	725	178	180	232	358	670	80	94

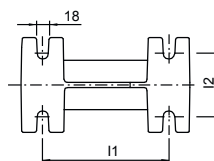
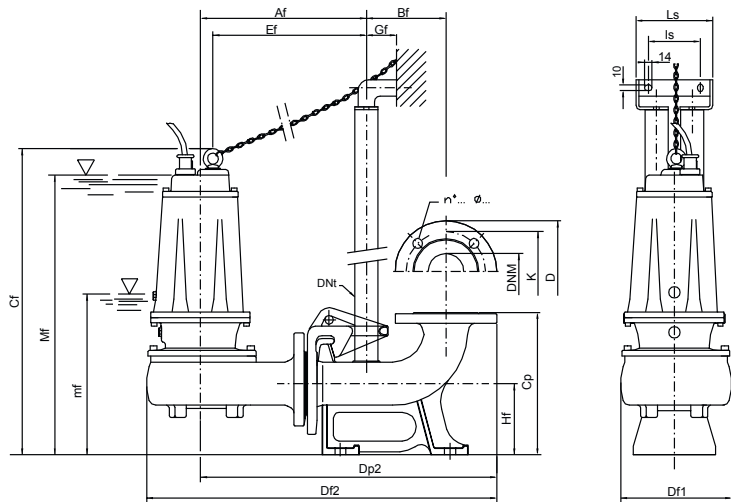

mt/mf: minimum working level
 Mt/Mf: minimum submersion level for continuous duty

Flange UNI PN 10 (mm)			
DNM	K	D	n°... Ø...
65	145	185	4... 18...
80	160	200	8... 18...

TYPE	DIMENSIONS (mm)																	
	Af	Bf	Cf	Cp	Df1	Df2	Dp2	DNt	Ef	Gf	Hf	l1	l2	ls	Ls	mf	Mf	DNM
DMT 160 / P	303	145	560	260	200	639	542	1" 1/4	280	55	130	200	100	95	140	251	521	65
DM 160 / P, DMT 210 / P	303	145	560	260	200	639	542	1" 1/4	280	55	130	200	100	95	140	251	521	65
DM 210 / P, DMT 310 / P	303	145	560	260	200	639	542	1" 1/4	280	55	130	200	100	95	140	251	521	65
DMT 410 / P	350	165	690	340	220	722	615	2"	319	85	190	250	140	130	180	327	642	80
DMT 560 / P	350	165	690	340	220	722	615	2"	319	85	190	250	140	130	180	327	642	80
DMT 1000 / P	370	165	745	340	240	750	638	2"	350	85	190	250	140	130	180	380	690	80
DMT 1000/P	370	165	745	340	235	750	638	2"	338	85	190	250	140	130	180	380	690	80

TYPE	PROTECTION		1 PUMP CONTROL PANEL			2 PUMPS CONTROL PANEL		
	1 x 230 V	3 x 400 V	1 x 230 V	3 x 400 V	400 / 690 V	1 x 230 V	3 x 400 V	400 / 690 V
DM 160	PMC 15/35-15	PT 20-30-40/4.3-6.8	EQSM + 35µF	EQSMT 10		EQ2SM + 2x35µF	EQ2SMT 10	
DM 210	PMC 20/50-18	PT 20-30-40/4.3-6.8	EQSM + 50µF	EQSMT 10		EQ2SM + 2x50µF	EQ2SMT 10	
DMT 310		PT 40-50/5.7-9.1		EQSMT 10			EQ2SMT 10	
DMT 400		PT 55-75/8.6-13.5		EQSMT 10			EQ2SMT 10	
DMT 550		PT 55-75/8.6-13.5		EQSMT 10			EQ2SMT 10	
DMT 1000		PT 125-150/16-21		EQSMT 10	QST 10		EQ2SMT 10	Q2ST 10

