

# DV4

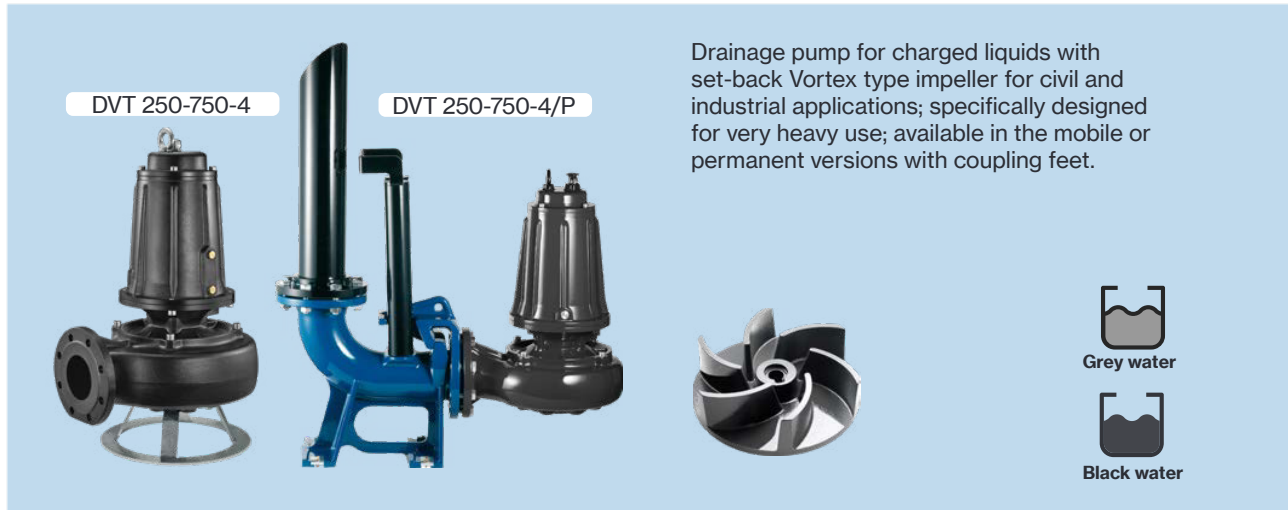

## Drainage Vortex



Drainage pump for charged liquids with set-back Vortex type impeller for civil and industrial applications; specifically designed for very heavy use; available in the mobile or permanent versions with coupling feet.

### Construction features

<b>Pump body</b>	cast iron
 <b>Impeller</b>	cast iron
<b>Mechanical seal</b>	double seal with oil barrier: silicon carbide on pump side, ceramic-graphite on motor side
<b>Motor shaft</b>	stainless steel AISI 304
<b>Free passage</b>	50 mm
<b>Max submergence</b>	max 20 m
<b>Liquid temperature</b>	0 - 40 °C
<b>Cable</b>	H05 RN8F, 10 m
<b>Bolts</b>	A2 stainless steel
<b>Foot support</b>	galvanized iron
<b>Gaskets</b>	NBR rubber

### Motor

<b>2 Poles induction motor</b>	3- 230/400V-50Hz P ≤ 4kW 3- 400/690V-50Hz P > 4kW
<b>Insulation class</b>	F
<b>Protection degree</b>	IPX8

TYPE	LOTS			
	TRUCK		CONTAINER	
	PALLET (cm)	N° pumps	PALLET (cm)	N° pumps
DVT 250-4/750-4	85×110×190	8	100×120×190	12

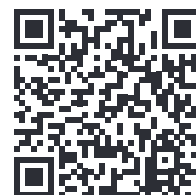
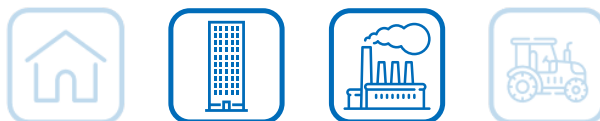

# DV4

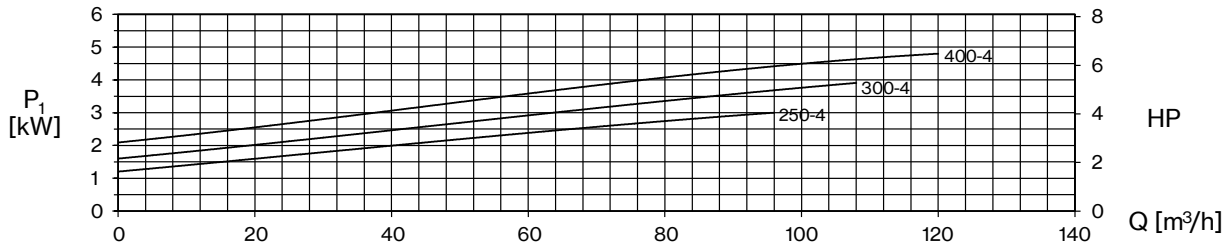
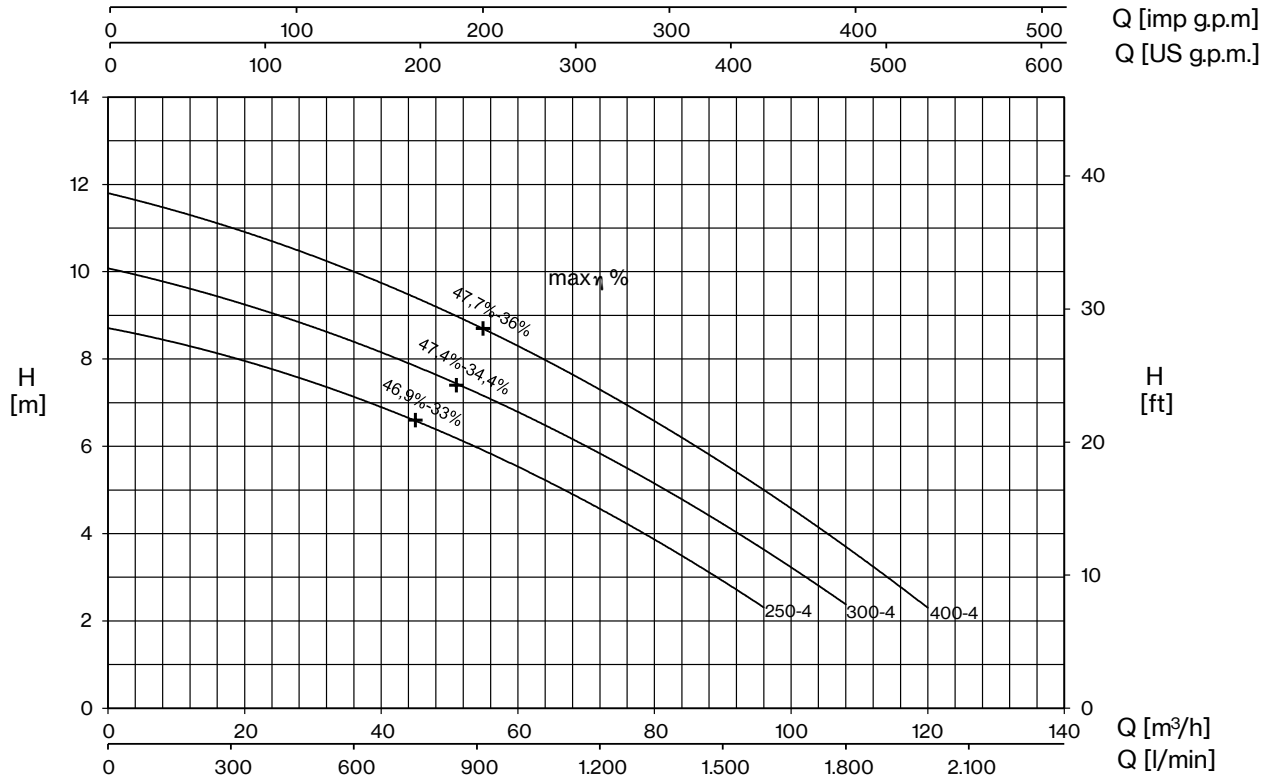

TYPE	AMPERE			
	3x230 V 50 Hz (*)	3x400 V 50 Hz	230/400 V 50 Hz $\lambda / \Delta$ (*)	400/690 V 50 Hz $\lambda / \Delta$
DVT 250-4	10	5,8	-	-
DVT 300-4	11,8	6,8	-	-
DVT 400-4	15,1	8,7	-	-

+ max  $\eta$  %

max hydraulic efficiency and respective total efficiency

(\*) no standard execution

TYPE	P <sub>2</sub>		P <sub>1</sub> (kW)	Q (m³/h - l/min)											
				0	12	24	36	48	60	72	84	96	108	120	
	HP	kW	3~	0	200	400	600	800	1000	1200	1400	1600	1800	2000	
	H (m)														
DVT 250-4	2,5	1,8	3,3	8,7	8,3	7,8	7,1	6,4	5,5	4,6	3,5	2,3			
DVT 300-4	3	2,2	4,1	10,1	9,6	9,0	8,4	7,7	6,8	5,8	4,8	3,6	2,4		
DVT 400-4	4	3	4,9	11,8	11,3	10,7	10,0	9,2	8,3	7,3	6,2	5,0	3,7	2,3	



# DV4

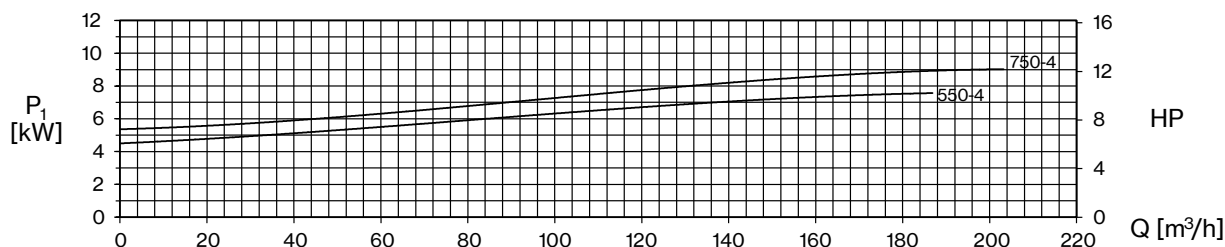
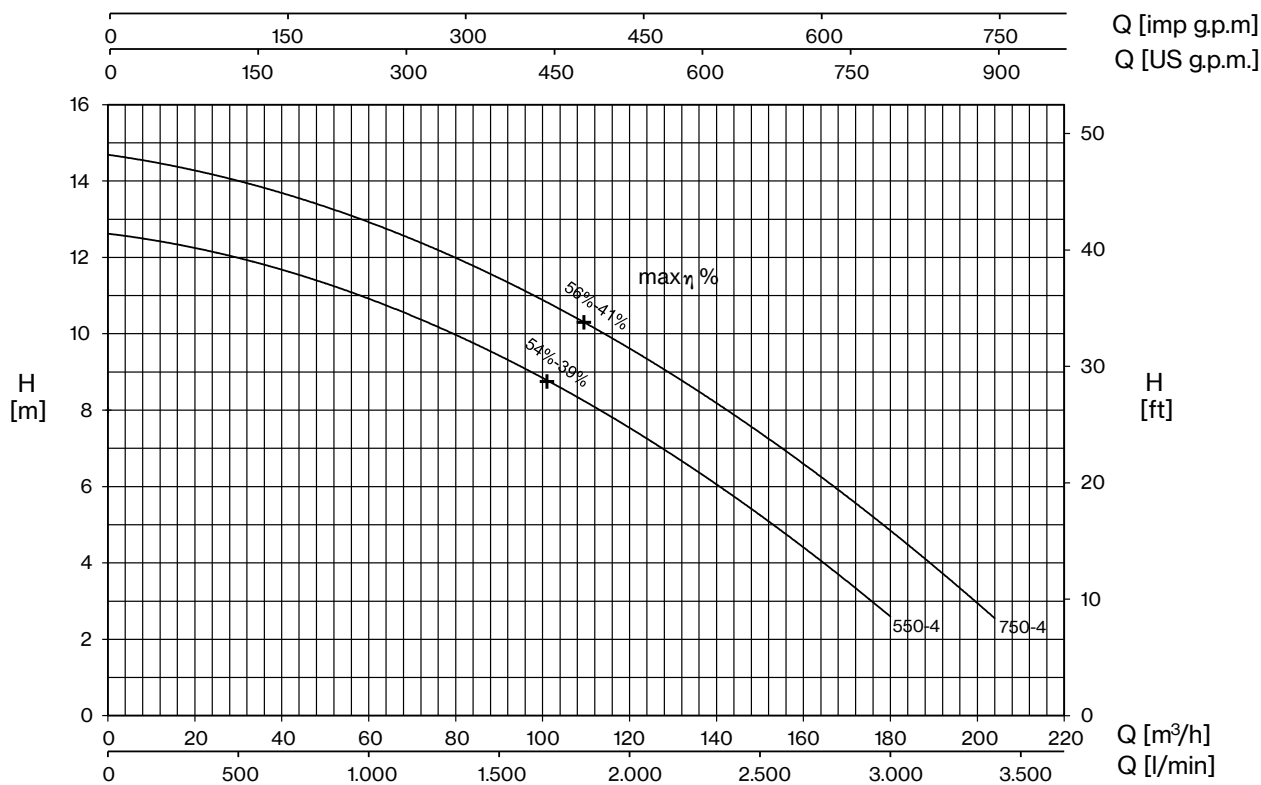

TYPE	AMPERE			
	3x230 V 50 Hz (*)	3x400 V 50 Hz	230/400 V 50 Hz λ / Δ (*)	400/690 V 50 Hz λ / Δ
DVT 550-4	-	12,9	22,3	12,9
DVT 750-4	-	15,4	26,6	15,4

**+ max η %**

max hydraulic efficiency and respective total efficiency

(\*) no standard execution

TYPE	P <sub>2</sub>		P <sub>1</sub> (kW)	Q (m³/h - l/min)											
				0	24	48	72	96	120	144	168	180	192	204	
	HP	kW	3~	0	400	800	1200	1600	2000	2400	2800	3000	3200	3400	
DVT 550-4	5,5	4	7,5	12,6	12,2	11,4	10,3	9,1	7,6	5,7	3,7	2,6			
DVT 750-4	7,5	5,5	9	14,7	14,2	13,3	12,4	11,2	9,6	7,9	5,9	4,8	3,7	2,6	



# DV4

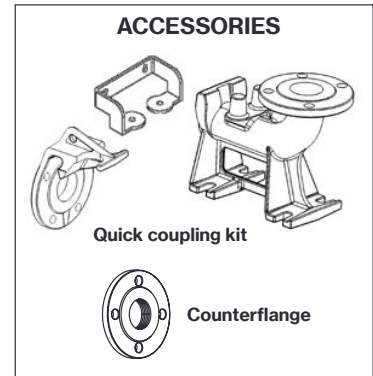
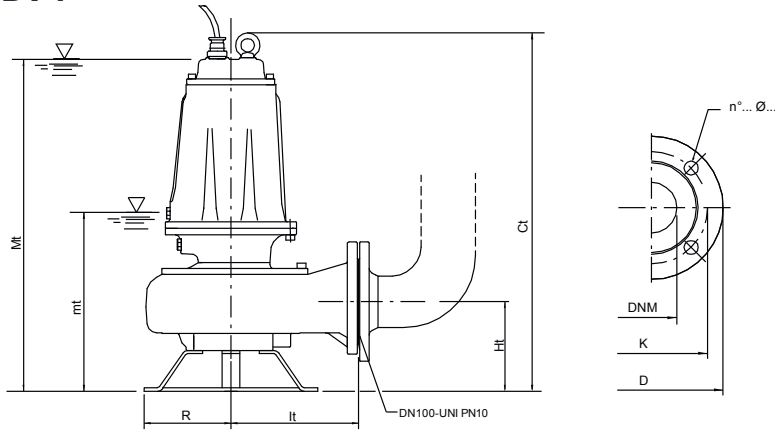

TYPE	DIMENSIONS (mm)							Kg
	Ct	Ht	R	lt	mt	Mt	DNM	
DVT 250-4	660	165	160	235	300	614	100	69,5
DVT 300-4	660	165	160	235	300	614	100	71
DVT 400-4	660	165	160	235	300	614	100	74,5
DVT 550-4	715	195	180	276	385	695	100	101,5
DVT 750-4	715	195	180	276	385	695	100	106

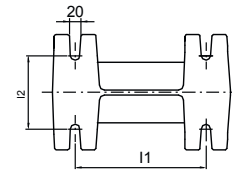
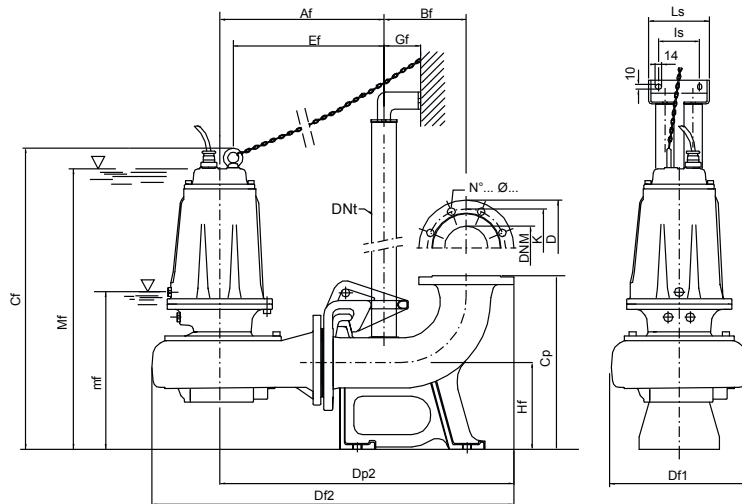

mt/mf: minimum working level  
Mt/Mf: minimum submergence level for continuous duty

Flange UNI PN 10 (mm)			
DNM	K	D	n°... Ø...
100	180	220	8... 18...

TYPE	DIMENSIONS (mm)																	
	Af	Bf	Cf	Cp	Df1	Df2	Dp2	Dnt	Ef	Gf	Hf	l1	l2	ls	Ls	mf	Mf	DNM
DVT 250-4/P	378	190	695	400	317	835	678	2"	347	85	200	250	140	130	180	335	650	100
DVT 300-4/P	378	190	695	400	317	835	678	2"	347	85	200	250	140	130	180	335	650	100
DVT 400-4/P	378	190	695	400	317	835	678	2"	347	85	200	250	140	130	180	335	650	100
DVT 550-4/P	419	190	755	400	371	900	719	2"	384	85	200	250	140	130	180	390	700	100
DVT 750-4/P	419	190	755	400	371	900	719	2"	384	85	200	250	140	130	180	390	700	100

TYPE	PROTECTION	1 PUMP CONTROL PANEL		2 PUMPS CONTROL PANEL	
	3 x 400 V	3 x 400 V	400 / 690 V	3 x 400 V	400 / 690 V
DVT 250-4	PT 40-50/5.7-9.1	EQSMT 10		EQ2SMT 10	
DVT 300-4	PT 40-50/5.7-9.1	EQSMT 10		EQ2SMT 10	
DVT 400-4	PT 55-75/8.6-13.5	EQSMT 10		EQ2SMT 10	
DVT 550-4	PT 55-75/8.6-13.5	EQSMT 10		EQ2SMT 10	
DVT 750-4	PT 100/12.5-16.5	EQSMT 10	QST 10	EQ2SMT 10	Q2ST 10

