

Drainage pump with set-back Vortex type impeller for pumping charged waters and liquids with suspended solids; ideal for civil and household applications.

Construction features

Pump body	cast iron with openings 1" ½ and 2"
Shell, motor cover, base support	stainless steel
 Impeller	stainless steel set-back Vortex
Mechanical seal	double seal with oil barrier: silicon carbide on pump side, sealing ring on motor side
Motor shaft	stainless steel AISI 430
Free passage	Ø max 35 mm (80-100) Ø max 50 mm (82-102)
Max submergence	max 5 m
Liquid temperature	0 - 40 °C
Cable	H05 RN8F, 10 m
G	float switch

Motor

2 Poles induction motor	3~ 3x400V-50Hz 1- 1x230V-50Hz (with thermal protection)
Insulation class	F
Protection degree	IPX8

TYPE	LOTS			
	TRUCK		CONTAINER	
	PALLET (cm)	N° pumps	PALLET (cm)	N° pumps
DG	80x120x145	48	80x120x190	76



DG

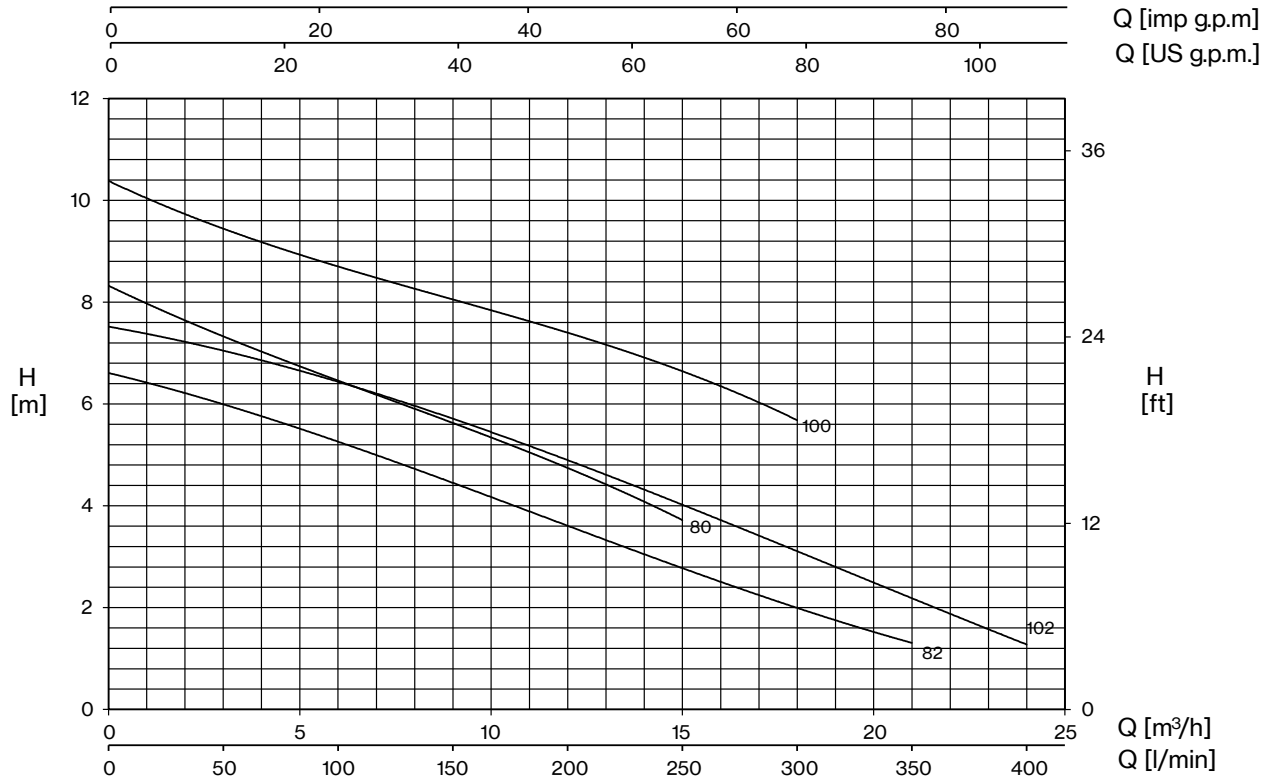

TYPE		W	AMPERE		Q (m³/h - l/min)									
1~	3~		1~	3~	0	3	6	9	12	15	18	21	24	
					0	50	100	150	200	250	300	350	400	
		1x230 V 50 Hz	3x400 V 50 Hz	H (m)										
DG 80 (G)	DGT 80	1050	4,7	2,2	8,3	7,4	6,4	5,6	4,8	3,7				
DG 80/2 (G)	DGT 80/2	1050	4,7	2,2	8,3	7,4	6,4	5,6	4,8	3,7				
DG 100 (G)	DGT 100	1350	6,2	2,8	10,4	9,4	8,7	8,1	7,4	6,6	5,7			
DG 100/2 (G)	DGT 100/2	1350	6,2	2,8	10,4	9,4	8,7	8,1	7,4	6,6	5,7			
DG 82 (G)	DGT 82	1000	4,5	2,1	6,6	6,0	5,3	4,4	3,6	2,8	2,0	1,3		
DG 102 (G)	DGT 102	1200	5,3	2,4	7,5	7,1	6,4	5,7	4,9	4,0	3,2	2,1	1,3	

E: maximum emptying level
Mt: minimum liquid level for continuous duty

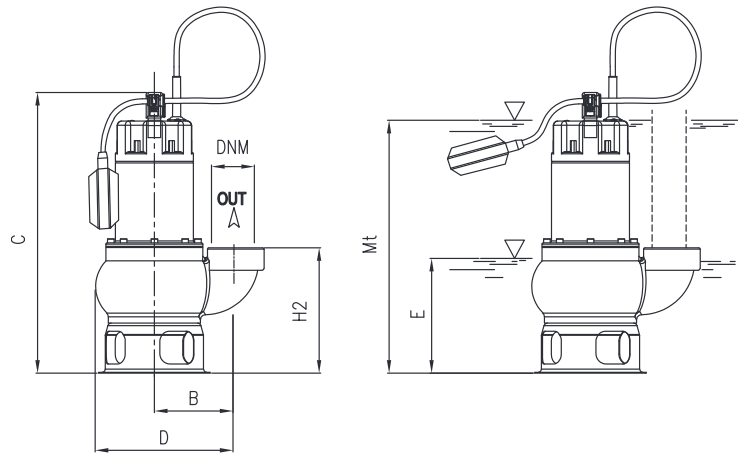

TYPE	DIMENSIONS (mm)										Kg
	B	C	D	E	H2	Mt	DNM	I	L	M	
DG 80 (G)	110	410	230	140	174	290	1 1/2 G	250	183	448	13,5
DG 80/2 (G)	110	410	230	140	174	290	2" G	250	183	448	14
DG 100 (G)	110	410	230	140	174	290	1 1/2 G	250	183	448	15,5
DG 100/2 (G)	110	410	230	140	174	290	2" G	250	183	448	15,5
DG 82 (G)	120	426	250	150	190	300	2" G	264	203	482	15
DG 102 (G)	120	426	250	150	190	300	2" G	264	203	482	16

